

# Compost turner

# CMC ST 350



Compost  
Systems



With a rotor length of 3.5 m and a heap cross-section of about 4 m<sup>2</sup>, Compost Systems expands its Agroline with the **CMC ST 350** for tractors above 100 hp. With or without a super creeper gear, the **CMC ST 350** works well with a push axle (option) even without creeper speed. The turner has a transport height of more than 4.6 m, which is not suitable

for transport on public roads. The advantage: The rotor can be lifted from the heap at any time just as the smaller CMC-models. As with the smaller models the classic construction on top of a trailer ensures that lateral forces are stabilised and not transferred to the tractor. **The CMC ST 350 corresponds to the strict criteria of Controlled Microbial Composting.**



# Compost turner

# CMC ST 350



Compost  
Systems

## Technical data

Maximum width:	4.00 m
Maximum height:	1.90 m
Rotor length:	3.50 m
Transport height:	4.70 m
Transport weight:	~ 2.80 t
incl. counter weight:	~ 8.50 t
PTO:	Bondioli
Color:	Grey / Blue
Tractor power:	from 100 hp
Turning quantity:	up to 1,200 m <sup>3</sup> /h
Working speed:	100 - 750 m/h (depending on windrow size, density, process progress)

### Options:

- Hydraulic drive wheels
- Hydraulic front shovels
- Hydraulic control block
- Stainless steel rotor tunnel
- Innoculation system
- Special colours
- Irrigation boom
- 1,000 l Irrigation/innoculation combination
- Lighting system 12 Volt
- Brake system
- Towing hitch above PTO
- Fleece roller

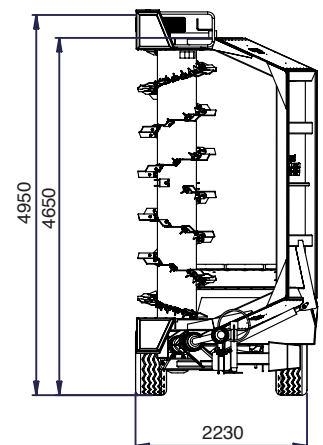
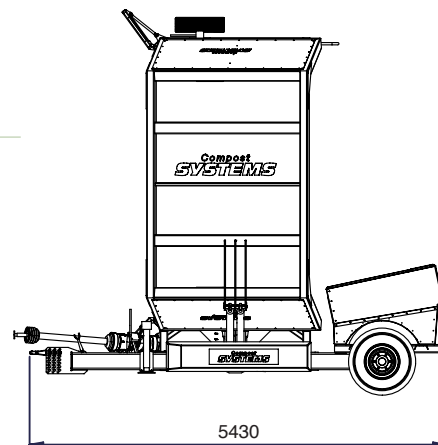
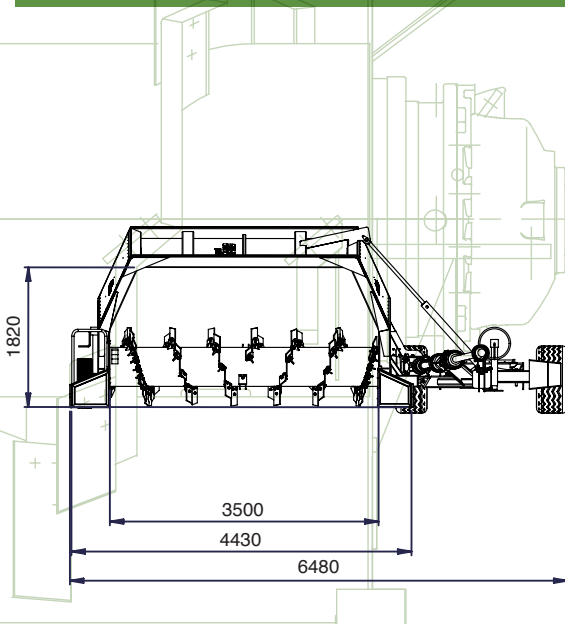

All information is subject to change without notice. Printing errors reserved.