

## *Encoder*

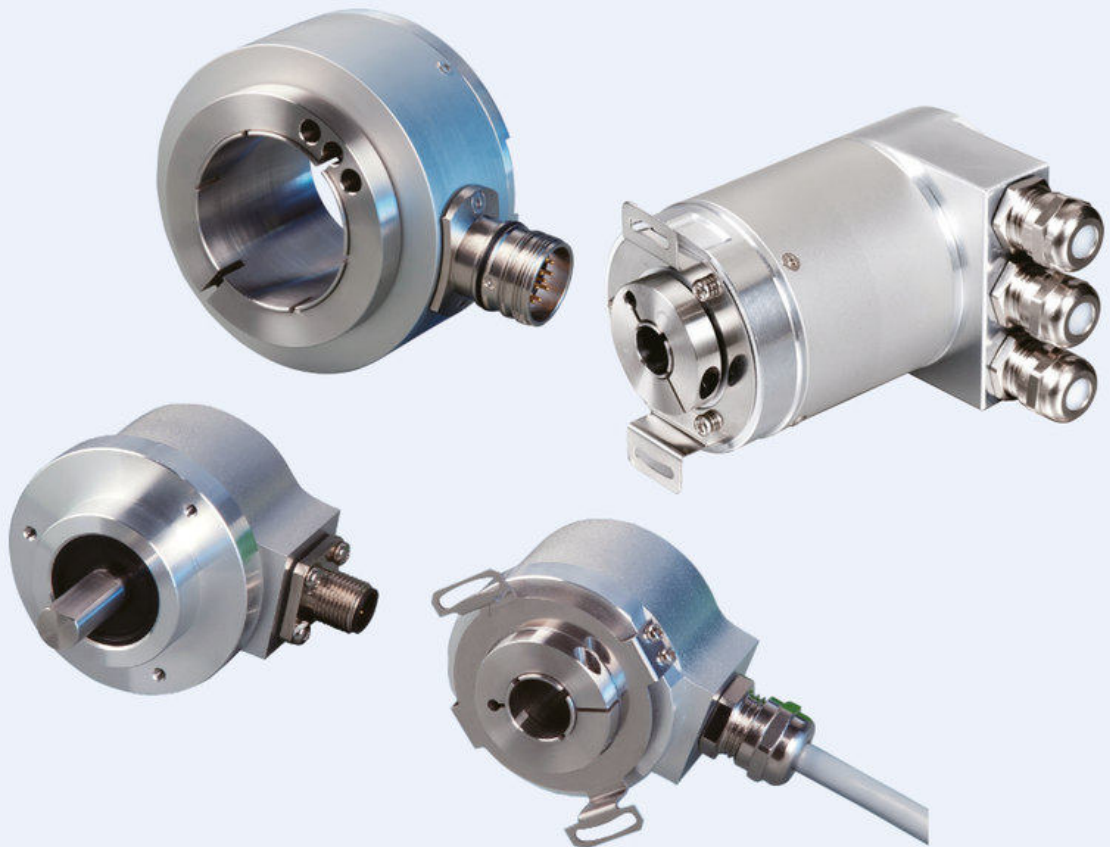

# COMPANY PROFILE

## Company Profile

---

Elco (Tianjin) Electronics Co., Ltd. is a leading enterprise in China's industrial automation. It was established in Tianjin in 2003, and its sales and service network covers the whole country. As a provider of local industrial automation products and a supplier of intelligent manufacturing solutions in China, Elco has occupied a leading position in automobiles, auto parts, construction machinery, robots, food and pharmaceutical, printing and packaging, textile machinery, logistics equipment, electronics manufacturing and many other fields.

ELCO provides the full range of services from system layer, control layer, network layer to execution layer to the implementation of overall planning of intelligent factory. The products and solutions are not limited to the ElcoCloud platform and include MES (Manufacturing Execution System), Industrial Fieldbus, Industrial Ethernet, Industrial wireless communication, IoT gateway chip, automated production lines consisting of robotics and intelligent equipments, integration of automatic & electric controlling system, intelligent logistics warehouse system, IoT integrated development solutions and services etc. This leads to a truly intelligent manufacturing and improves the productivity, efficiency and flexibility.

Over several years, ELCO provides comprehensive support for the development of China's manufacturing industry through innovative technology, excellent products and solutions. To meet the customers needs all over the world and to allow global availability and competitive prices, Elco has established a new branch in Germany: Elco Industrie Automation in Oberstenfeld.



## Contents

© Easydic Series Shaft Incremental Encoder EV28 .....	04
© Topydic Small Shaft Incremental Encoder EV40A .....	07
© Topydic Small Hollow Shaft Incremental Encoder EV40P .....	11
© Topydic Series Shaft Incremental EV50A .....	15
© Topydic Series Shaft Incremental EV50P .....	18
© Topydic Series Shaft Incremental Encoder EV58A .....	21
© Topydic Series Hollow Shaft Incremental Encoder EV58P .....	25
© Heavydic Large Hollow Shaft Incremental Encoder EV90P .....	28
© Topydic Series Large Hollow Shaft Incremental Encoder EV150P .....	30
© EVL Support .....	35
© Coupling .....	38
© Compact absolute multiturn encoder EMM36 .....	41
© Miniature Absolute Singleturn Encoder EAC50 .....	45
© Profibus-DP Interface Absolute Singleturn Encoder EAC58 .....	48
© 4...20mA Analog Output Absolute Singleturn Encoder EAC58 .....	53
© Standard Absolute Singleturn Encoder EAC58 .....	56
© Standard Hollow Shaft Absolute Singleturn Encoder EAC58P .....	60
© 4...20mA Analog Output Absolute Multiturn Encoder EAM58 .....	64
© Standard Absolute Multiturn Encoder EAM58 .....	68
© Profibus-DP Interface Absolute Multiturn Encoder EAM58 .....	72
© Profinet Absolute Multiturn Encoder .....	76
© Profinet Protocol Absolute Multi-turn Encoder EAM58 .....	80
© EtherNet/IP Interface Absolute Multiturn Encoder EAM58 .....	83
© EtherCAT Interface Absolute Multiturn Encoder EAM58 .....	86
© CANopen Interface Absolute Multiturn Encoder EAM58 .....	89
© Large Hollow Shaft Profibus-DP Interface Absolute Multiturn Encoder EAM90L .....	92
© Large Hollow Shaft Absolute Multiturn Encoder EAM90L .....	96
© Draw Wire Mechanics EVD Series .....	99

## Easydic Series Shaft Incremental Encoder EV28



### Description

Small economical shaft encoder EV28 is widely used in light industries where space for sensor installation is a concern. The resolution is up to 600, and with its small size, light weight and high precision, it fully meets the controlling requirements of the modern light industries. With the different shaft lengths available, the product can be used in a wide variety of industrial environments. It's one of the most recommended choices when considering performance and cost.

### Features

- Flexible coupling connection avoids damage to the encoder
- Stainless steel shaft  $\Phi 4$ 、 $\Phi 5$  ensures high stability and protection
- Metal housing for better shock resistance
- Protection class IP50
- Reverse connection protection
- Short circuit protection
- Cable output, waterproof rubber end

### Mechanical parameters

Shaft diameter	$\phi 4/\phi 5g6$ mm
Protection class	IP50
Speed	6000 rpm, continuous
Max load capacity of the shaft	5 N axial, 10 N radial
Shock resistance	30G/11 ms
Vibration resistance	6G 10...2000 HZ
Bearing life	$10^9$ revolution
Moment of inertia	approx. $0.7 \times 10^{-6}$
Starting torque	$< 0.01$ Nm
Body material	AL - alloy UNI 9002-5
Housing material	AL - alloy UNI 9002-5
Operating temperature	-20...+80 C
Storage temperature	-30...+85 C
Weight	100 g

Resolution:  
50,100,200,300,360,500,600

### Electrical parameters

Output circuit	Push-pull	RS422	RS422
Resolution	Max. 600 ppr	Max. 600 ppr	Max. 600 ppr
Supply voltage	10...30 VDC / 5...30 VDC	5 VDC	10...30 VDC
Power consumption (no load)	$\leq 125$ mA	$\leq 80$ mA	$\leq 80$ mA
Permissible load (channel)	$\pm 80$ mA	$\pm 50$ mA	$\pm 50$ mA
Pulse frequency	Max. 300 kHz	Max. 300 kHz	Max. 300 kHz
Signal level high	Min. $U_b - 1.5$ V	Min. 3.4 V	Min. 3.4 V
Signal level low	Max. 0.8 V	Max. 0.4 V	Max. 0.4 V
Rise time Tr	Max. 1 $\mu$ s	Max. 200 ns	Max. 200 ns
Fall time Tr	Max. 1 $\mu$ s	Max. 200 ns	Max. 200 ns

### Terminal Assignment

Signal	0V	+U <sub>b</sub>	A	$\bar{A}$	B	$\bar{B}$	Z	$\bar{Z}$	Shield
Color	WH	BN	GN	YE	GY	PK	BU	RD	$\perp$

## Easydic Series Shaft Incremental Encoder EV28

Dimensions (mm)

EV28

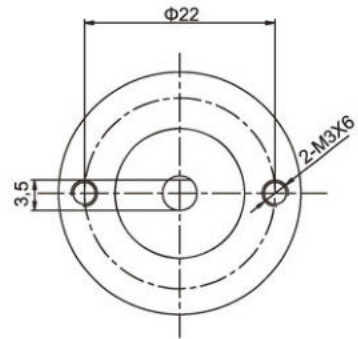
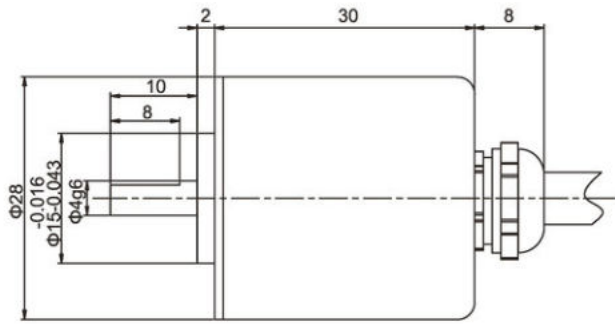



## Topydic Small Shaft Incremental Encoder EV40A



### Description

Topydic series small shaft incremental encoder-EV40A delivers outstanding performance in mechanical shock-resistance and can withstand higher axial and radial loads to suit various industrial environments. Its special position of cabling fits to the limited installation space. Combining advanced signal processing technology with multiple types of electrical output, EV40A are capable of matching various upper control computers.

### Features

- Stainless steel shaft ensures safety and stability in operation
- Optional types of flange connection offers more flexibility
- Metal casting housing for greater shock resistance
- Side cabling design greatly saves the installation space and simplifies wiring
- Reverse connection protection; short circuit protection

### Mechanical parameters

Shaft diameter	Φ6g6 mm
Protection class	IP66 standard, IP67 optional
Max. speed/minute	6000 rpm
Max. load capacity of the shaft	60 N axial 100 N radial
Shock resistance	50G/11 ms
Vibration resistance	10G 10~2000 HZ
Bearing life	10 <sup>9</sup> revolution
Moment of inertia	1.9×10 <sup>-6</sup> kgm <sup>2</sup>
Starting torque	<0.08 Nm
Body material	Al-alloy
Housing material	Zn-alloy
Operating temperature	-20...+85 °C
Storage temperature	-25...+100 °C
Weight	110 g

Regular resolution: 10, 20, 30, 40, 50, 60, 70, 80, 90, 100, 200, 300, 360, 400, 500, 512, 600, 800, 1000, 1024, 2000, 4000, 2500, 5000, 2048

Note: the products with above resolutions are available from stock, others on request.

### Electrical parameters

Output circuit	RS422	Push-pull
Resolution	Max.5000 ppr	Max.5000 ppr
Supply voltage	5±0.25 or 10...30 VDC	10...30 VDC
Power consumption(no load)	≤80 mA	≤125 mA
Permissible load(channel)	±50 mA	±80 mA
Pulse frequency	Max.800 kHz	Max. 800 kHz
Signal level high	Min. 3.4 V	Min.Ub-1.8 V
Signal level low	Max. 0.4 V	Max. 2.0 V
Rise time Tr	Max. 200 ns	Max. 1 μs
Fall time Tf	Max. 200 ns	Max. 1 μs

# Topydic Small Shaft Incremental Encoder EV40A

## Terminal Configuration

Signal	0V	+U <sub>b</sub>	A	$\bar{A}$	B	$\bar{B}$	Z	$\bar{Z}$	Shield
Color	WH	BN	GN	YE	GY	PK	BU	RD	⊥
Pin	10	12	5	6	8	1	3	4	PH

## Dimensions (mm)

EV40A

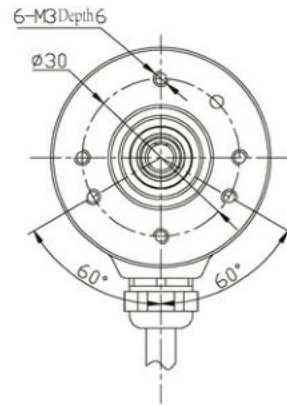
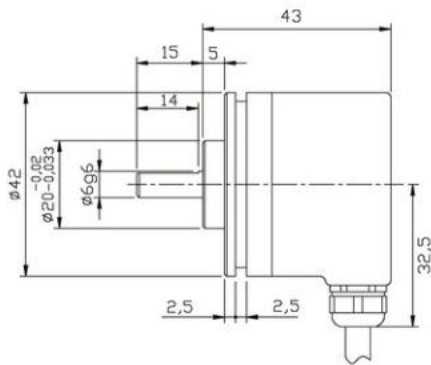

EV40B

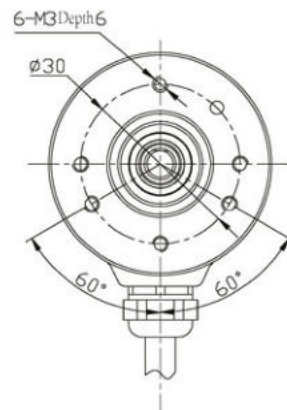
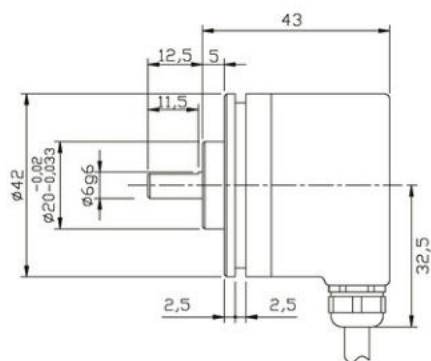

## Topydic Small Shaft Incremental Encoder EV40A

Dimensions (mm)

EV40C

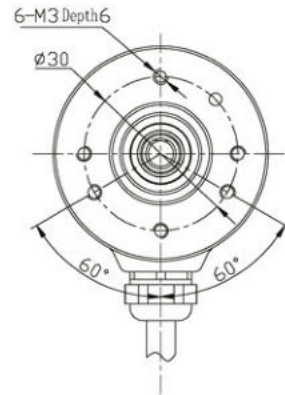
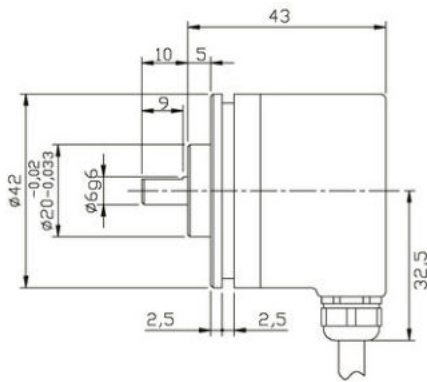

EV40A side pre-wired cable

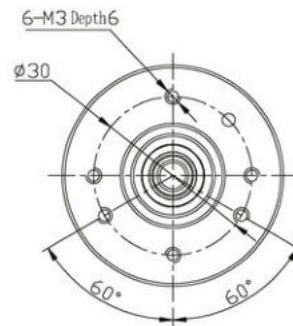
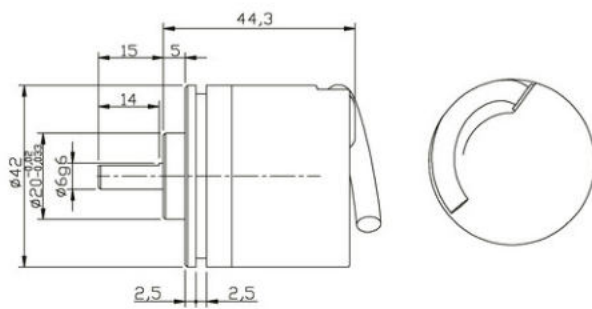

# Topydic Small Shaft Incremental Encoder EV40A

Order Code:

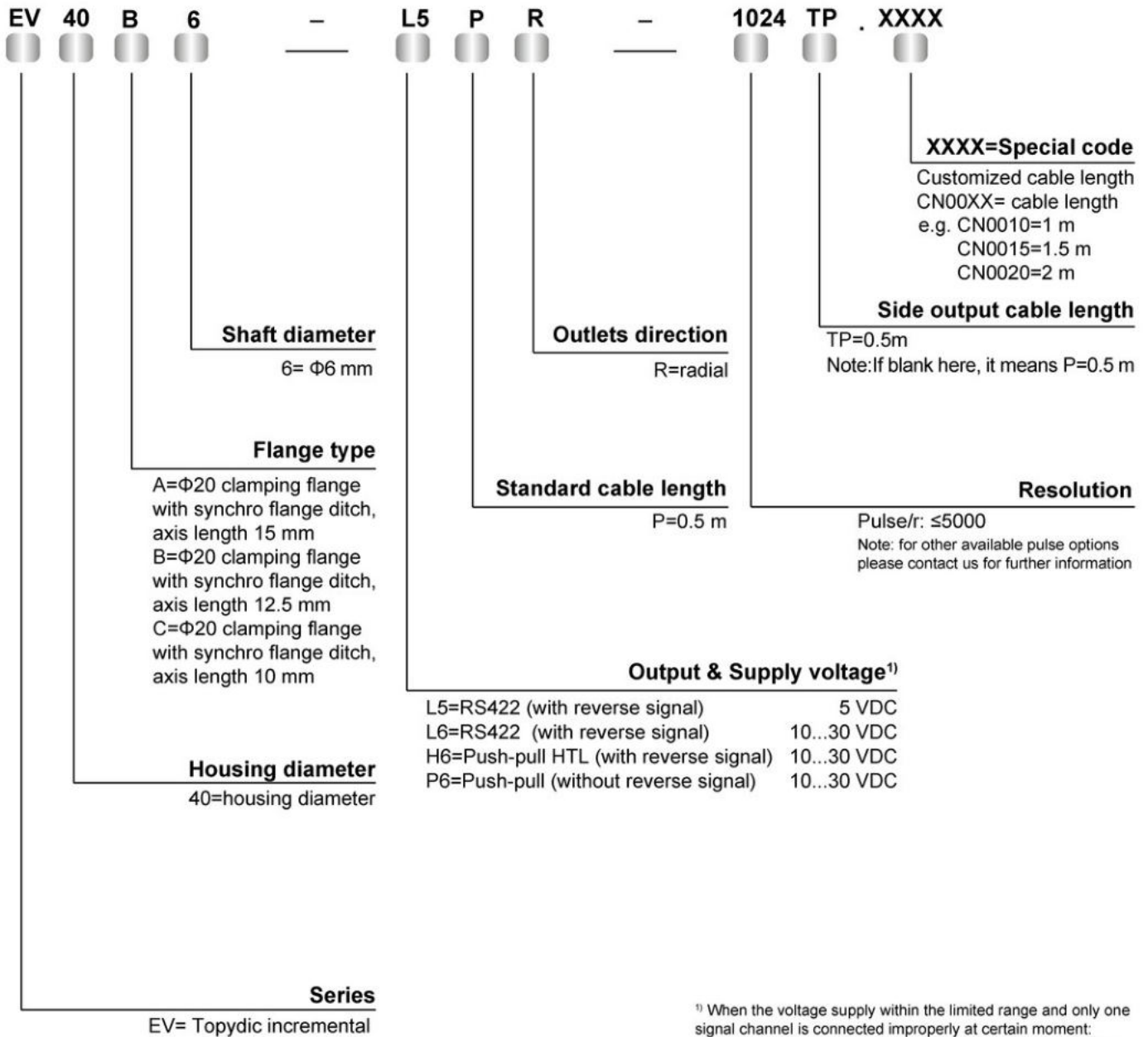

<sup>1)</sup> When the voltage supply within the limited range and only one signal channel is connected improperly at certain moment:  
 if  $U_b = 5V$ , it's permitted to connect to signal channels, 0V or  $U_b$ ;  
 if  $U_b > 5V$ , it's permitted to connect to signal channels or 0V.

## Topydic Small Hollow Shaft Incremental Encoder EV40P



### Description

Topydic series small shaft incremental encoder-EV40P delivers outstanding performance in mechanical shock-resistance and can withstand higher axial and radial loads to suit various industrial environments. Its special position of cabling fits to the limited installation space. Combining advanced signal processing technology with multiple types of electrical output, EV40P are capable of matching various upper control computers.

### Features

- Stainless steel shaft ensures safety and stability in operation
- Optional types of flange connection offers more flexibility
- Metal casting housing for greater shock resistance
- Side cabling design greatly saves the installation space and simplifies wiring
- Reverse connection protection; short circuit protection

### Mechanical parameters

Shaft diameter	Φ6H7/Φ8H7 mm
Protection class	IP66 standard, IP67 optional
Max. speed/minute	6000 rpm
Max. load capacity of the shaft	60 N axial 100 N radial
Shock resistance	50G/11 ms
Vibration resistance	10G 10~2000 HZ
Bearing life	10 <sup>9</sup> revolution
Moment of inertia	1.9×10 <sup>-6</sup> kgm <sup>2</sup>
Starting torque	<0.08 Nm
Body material	Al-alloy
Housing material	Zn-alloy
Operating temperature	-20...+85 °C
Storage temperature	-25...+100 °C
Weight	110 g

Regular resolution:10, 20, 30, 40, 50, 60, 70, 80, 90, 100, 200, 300, 360, 400, 500, 512, 600, 800, 1000, 1024, 1200, 1250, 2000, 2500, 4000, 5000

Note: the products with above resolutions are available from stock, others on request.

### Electrical parameters

Output circuit	RS422	Push-pull
Resolution	Max.5000 ppr	Max.5000 ppr
Supply voltage	5±0.25 or 10...30 VDC	10...30 VDC
Power consumption(no load)	≤80 mA	≤125 mA
Permissible load(channel)	±50 mA	±80 mA
Pulse frequency	Max.800 kHz	Max. 800 kHz
Signal level high	Min. 3.4 V	Min.Ub-1.8
Signal level low	Max. 0.4 V	Max. 2.0 V
Rise time Tr	Max. 200 ns	Max.1 μs
Fall time Tf	Max. 200 ns	Max.1 μs



## Topydic Small Hollow Shaft Incremental Encoder EV40P

### Dimensions (mm)

#### EV40H

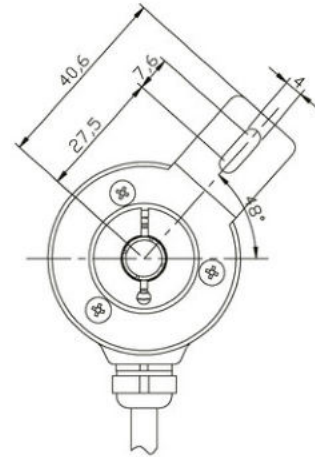
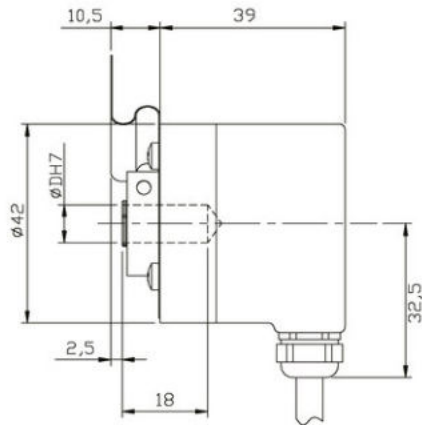

#### EV40W side pre-wired cable

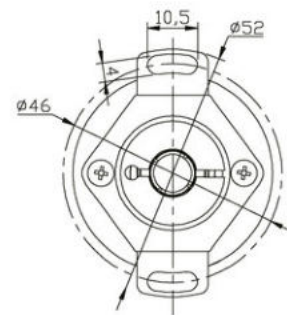
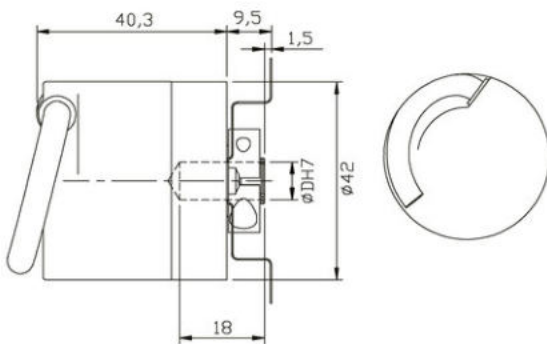

# Topydic Small Hollow Shaft Incremental Encoder EV40P

Order Code:

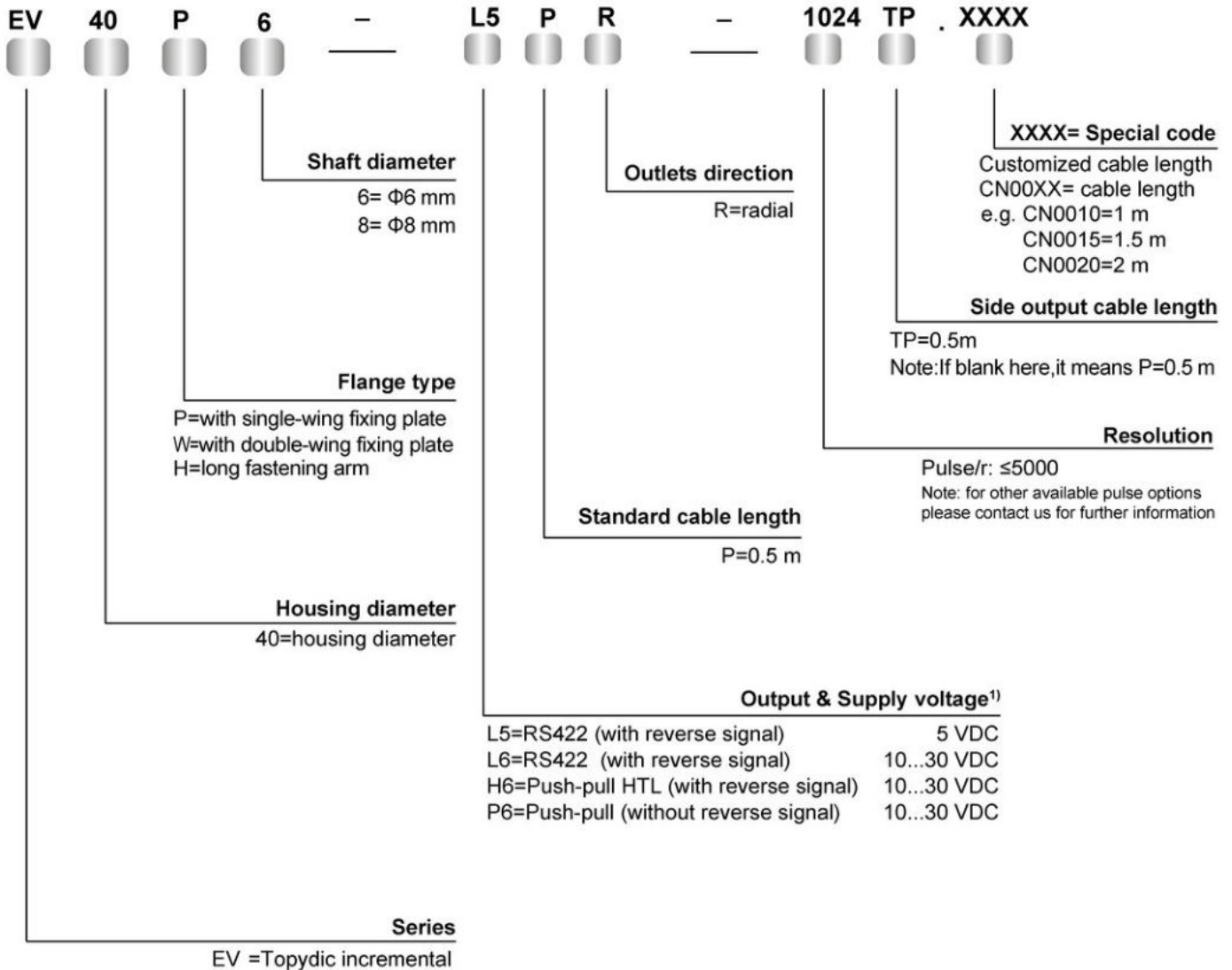

<sup>1)</sup> When the voltage supply within the limited range and only one signal channel is connected improperly at certain moment:  
if  $U_s=5$  V, it's permitted to connect to signal channels, 0V or  $U_s$ ;  
if  $U_s > 5$  V, it's permitted to connect to signal channels or 0V.

## Topydic Series Shaft Incremental EV50A

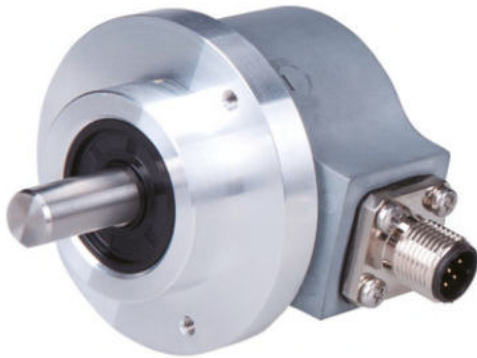

### Description:

Topydic series shaft incremental encoder EV50A, with double-bearing and casting housing, has excellent performance to resist mechanical shocks and can be used in various industrial environments; being compatible with standard flange types-50 mm and 58 mm, it can meet different application requirements; its wide voltage range, reverse connection and short circuit protection can effectively avoid mis-wiring.

### Features:

- Resolution up to 5000 ppr; pulse frequency up to 300 kHz
- Hollow shaft diameter,  $\phi 6$ - $\phi 12$  mm
- Compatible with standard flange types-50 mm and 58 mm
- $\phi 50$  mm metal casting housing for limited installation space
- Operating temperature,  $-40...+85$  °C; IP67 protection class for outdoors application
- Multi signal output interfaces to meet different types of data acquisition of upper computer
- Optional output types-with cable, M12 connector and M23 connector
- Reverse connection and short circuit protection to ensure the safety<sup>1)</sup>

### Mechanical parameters

Shaft diameter	$\phi 6/\phi 8/\phi 10/\phi 12/\phi 1/4"/\phi 3/8"$
Protection class	IP65 (without oil seal)
	IP67 (with oil seal)
Speed	12000 rpm (without oil seal)
	6000 rpm (with oil seal)
Max. load capacity of the shaft	40 N axial
	80 N radial
Shock resistance	50G/ 11 ms
Vibration resistance	10G 10...2000 HZ
Bearing life	$10^9$ revolution
Moment of inertia	$1.9 \times 10^{-6}$ kgm <sup>2</sup>
Starting torque	< 0.01 Nm (IP65)
	< 0.05 Nm (IP67)
Body material	Al-alloy
Housing material	Al-alloy
Operating temperature	$-40...+85$ °C
Storage temperature	$-45...+90$ °C
Weight	approx. 400 g

Resolution: 100, 200, 300, 360, 400, 500, 512, 600, 800, 1000, 1024, 1200, 1250, 2000, 2048, 2500, 3600, 4096, 5000

Attention: the products with above resolutions are available from stock, others on request.

### Electrical parameters

Output circuit	RS422	Push-pull
Supply voltage	$5 \pm 0.25$ or $10...30$ VDC	$10...30$ VDC
Power consumption (no load)	typ. 40 mA	typ. 50 mA
	max. 90 mA	max. 100 mA
Permissible load (channel)	max. $\pm 20$ mA	max. $\pm 30$ mA
Pulse frequency	max. 300 kHz	max. 300 kHz
Signal level high	min. 2.5 V	min. $U_b - 1$ V
Signal level low	max. 0.5 V	max. 0.5 V
Rise time Tr	max. 200 ns	max. 1 $\mu$ s
Fall time Tf	max. 200 ns	max. 1 $\mu$ s

### Terminal Configuration

Signal	0V	+U <sub>b</sub>	A	$\bar{A}$	B	$\bar{B}$	Z	$\bar{Z}$	Shield
Color Code	WH	BN	GN	YE	GY	PK	BU	RD	$\perp$
Pin (12-pin)	10	12	5	6	8	1	3	4	PH
Pin (5-pin)	1	2	3	-	4	-	5	-	PH
Pin (8-pin)	1	2	3	4	5	6	7	8	PH

# Topydic Series Shaft Incremental EV50A

## Dimensions (mm)

EV50A

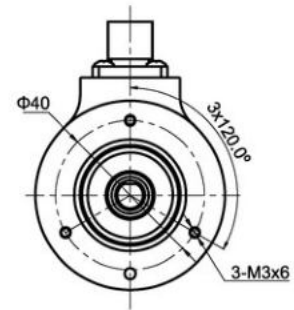
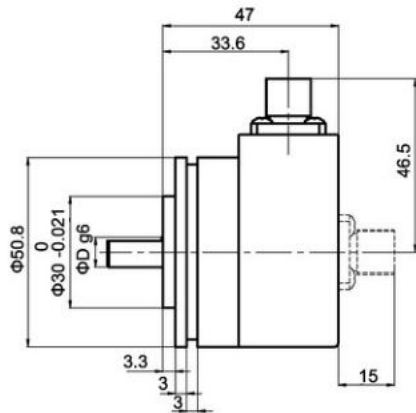

EV50B

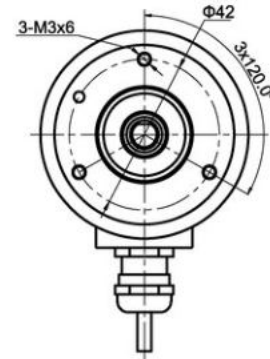
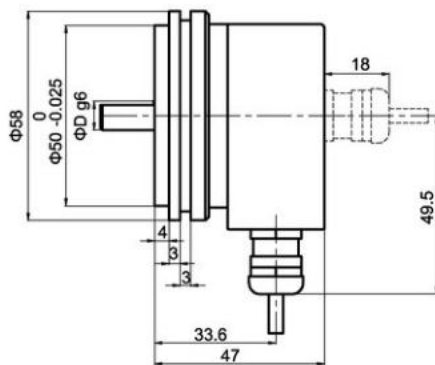

EV50C

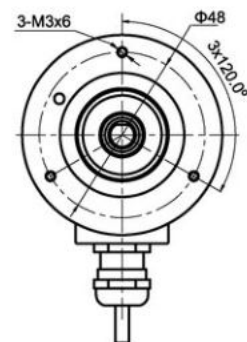
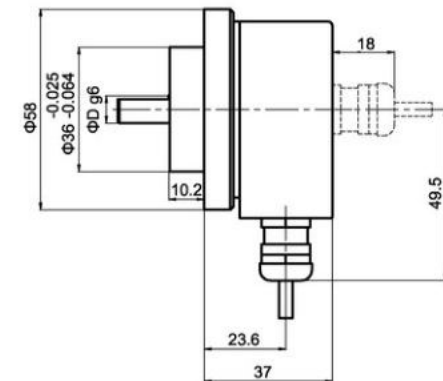

EV50D

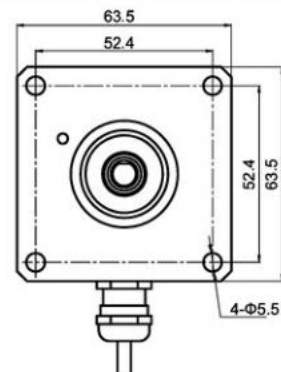
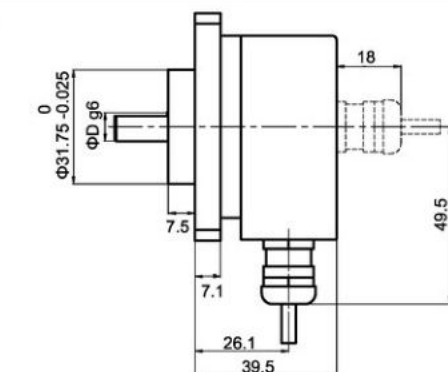



## Topydic Series Shaft Incremental EV50P



### Description

Topydic series shaft incremental encoder EV50P, with double-bearing and casting housing, has excellent performance to resist mechanical shocks and can be used in various industrial environments; stainless steel through-hole, shaft diameter of up to 15mm; its wide voltage range, reverse connection and short circuit protection can effectively avoid mis-wiring.

### Features

- Resolution up to 5000 ppr; pulse frequency up to 300 kHz
- Wide range of shaft diameter,  $\Phi 6\sim\Phi 15$  mm
- Hollow shaft installation, robust metal casting housing
- Operating temperature,  $-40\sim+85$  °C; IP67 protection class for outdoors application
- Housing thickness up to 46.3 mm for limited installation space
- Multi signal output interfaces to meet different types of data acquisition of upper computer
- Optional output types-with cable, M12 connector and M23 connector
- Reverse connection and short circuit protection to ensure the safety

### Mechanical parameters

Shaft diameter	$\Phi 6/\Phi 8/\Phi 10/\Phi 12/\Phi 14/\Phi 15/\Phi 1/4"/\Phi 3/8"/\Phi 1/2"/\Phi 5/8"$ mm
Protection class	IP65 (without oil seal) IP67 (with oil seal)
Speed	12000 rpm (without oil seal) 6000 rpm (with oil seal)
Max. load capacity of the shaft	40 N axial 80 N radial
Shock resistance	50G/11 ms
Vibration resistance	10G 10~2000 HZ
Bearing life	$10^9$ revolution
Moment of inertia	$6 \times 10^{-6}$ kgm <sup>2</sup>
Starting torque	<0.03 Nm (IP65) <0.08 Nm (IP67)
Body material	Al-alloy
Housing material	Al-alloy
Operating temperature	$-40\sim+85$ °C
Storage temperature	$-45\sim+90$ °C
Weight	Approx. 400 g

Regular resolution: 100, 200, 300, 360, 400, 500, 512, 600, 800, 1000, 1024, 1200, 1250, 2000, 2048, 2500, 3600, 4096, 5000

Attention: the products with above resolutions are available from stock, others on request.

### Electrical parameters

Output circuit	RS422	Push-pull
Supply voltage	$5 \pm 0.25$ or $10 \dots 30$ VDC	$10 \dots 30$ VDC
Power consumption(no load)	typ. 40 mA max. 90 mA	typ. 50 mA max. 100 mA
Permissible load(channel)	max. $\pm 20$ mA	max. $\pm 30$ mA
Pulse frequency	max. 300 kHz	max. 300 kHz
Signal level high	min. 2.5 V	min. $U_B - 1$ V
Signal level low	max. 0.5 V	max. 0.5 V
Rise time $T_r$	max. 200 ns	max. 1 $\mu$ s
Fall time $T_f$	max. 200 ns	max. 1 $\mu$ s

- 1) When the voltage supply within the limited range and only one signal channel is connected improperly at certain moment: if  $U_B = 5V$ , it's permitted to connect to signal channels, 0V or  $U_B$ ; if  $U_B > 5V$ , it's permitted to connect to signal channels or 0V.

## Topydic Series Shaft Incremental EV50P

### Terminal Configuration

Signal	0V	+U <sub>b</sub>	A	$\bar{A}$	B	$\bar{B}$	Z	$\bar{Z}$	Shield
Color	WH	BN	GN	YE	GY	PK	BU	RD	⊥
Pin(12-pin)	10	12	5	6	8	1	3	4	PH
Pin(5-pin)	1	2	3	-	4	-	5	-	PH
Pin(8-pin)	1	2	3	4	5	6	7	8	PH

### Dimensions(mm)

EV50K

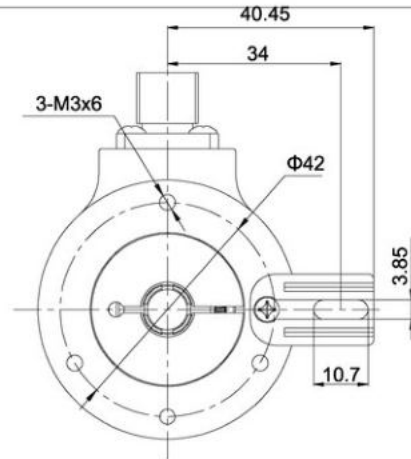
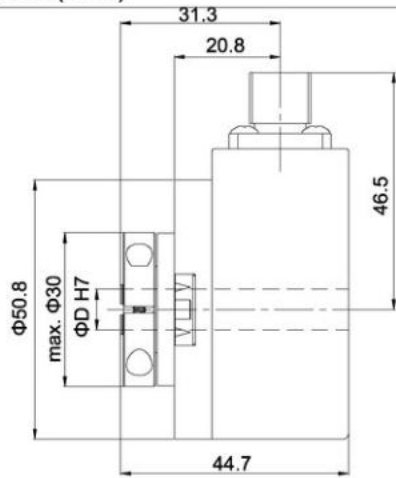

EV50H

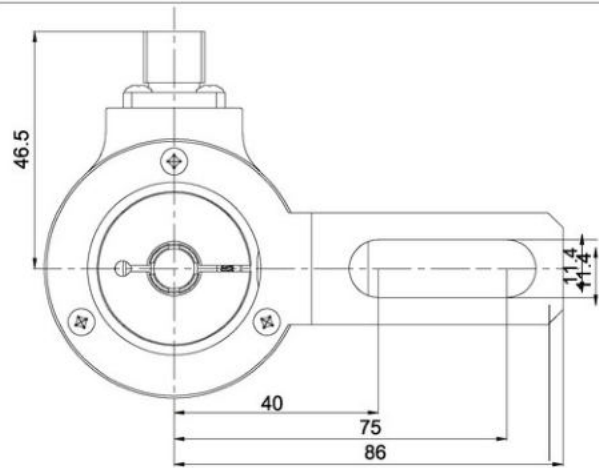
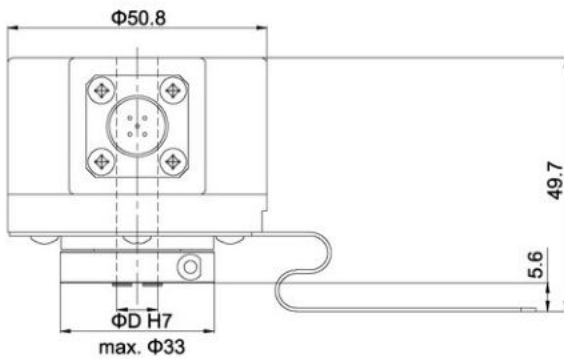

EV50W

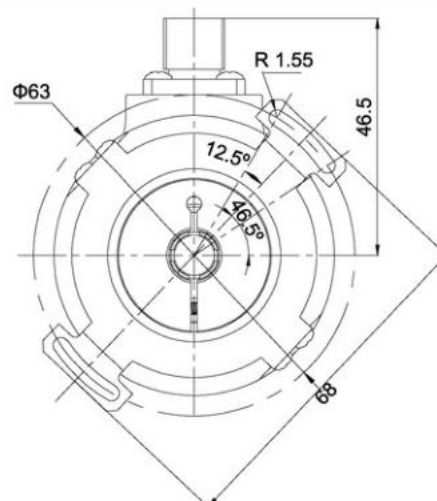
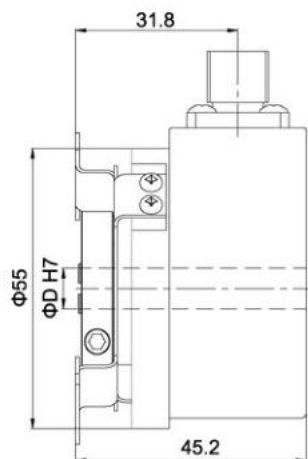



## Topydic Series Shaft Incremental Encoder EV58A



### Description:

Topydic series encoders EV58A are widely used in industrial environments. It delivers outstanding performance in mechanical shock resistance and is capable of withstanding higher axial and radial loads. Its flexible and variant mechanical structure & electrical circuit designs ensure perfect matches with multiple types of flanges or servo motors. They are compatible with all control computers.

### Features:

- Max resolution is up to 5000 pulse/r, output frequency is up to 300 kHz
- Stainless steel shaft  $\phi 6/\phi 8/\phi 10$ , flexible coupling connection ensures encoder safety during operation
- Various types of flanges, including imperial sizes
- Metal housing for greater shock resistance; compact structure is suited for limited installation space
- Protection class IP65
- Direct cable output or connector is more flexible and easy for maintenance
- The waterproof rubber ends ensure safety during operation
- Reverse connection protection, short circuit protection

### Mechanical parameters

Shaft diameter	$\Phi 6g6/\Phi 8g6/\Phi 10g6$ mm
Protection class	IP65
Speed	6000 rpm
Max. load capacity of the shaft	60 N axial 120 N radial
Shock resistance	50G/11 ms
Vibration resistance	10G 10~2000 HZ
Bearing life	$10^9$ revolution
Moment of inertia	$1.9 \times 10^{-6}$ kgm <sup>2</sup>
Starting torque	<0.01 Nm IP65
Body material	Al-alloy
Housing material	Al-alloy
Operating temperature	-20~+90 °C
Storage temperature	-40~+100 °C
Weight	300 g

Regular resolution: 360, 400, 500, 512, 600, 800, 1000,  
1024, 2000, 2500, 4000, 2048, 4096, 5000

Attention: the products with above resolutions are available from stock, others on request.

### Electrical parameters

Output circuit	RS422	Push-pull
Resolution	Max.5000 ppr	Max.5000ppr
Supply voltage	5±0.25 or 10...30 VDC	10...30 VDC
Power consumption(no load)	≤80 mA	≤125 mA
Permissible load(channel)	±50 mA	±80 mA
Pulse frequency	Max.300 kHz	Max.300 kHz
Signal level high	Min.3.4 V	Min. Ub-1.8
Signal level low	Max.0.4V	Max.2.0 V
Rise time Tr	Max 200 ns	Max 1μS
Fall time Tf	Max 200 ns	Max 1μS

## Topydic Series Shaft Incremental Encoder EV58A

### Terminal Configuration

Signal	0V	+U <sub>b</sub>	A	$\bar{A}$	B	$\bar{B}$	Z	$\bar{Z}$	Shield
Color	WH	BN	GN	YE	GY	PK	BU	RD	⊥
Pin	10	12	5	6	8	1	3	4	PH

### Dimensions (mm)

EV58A

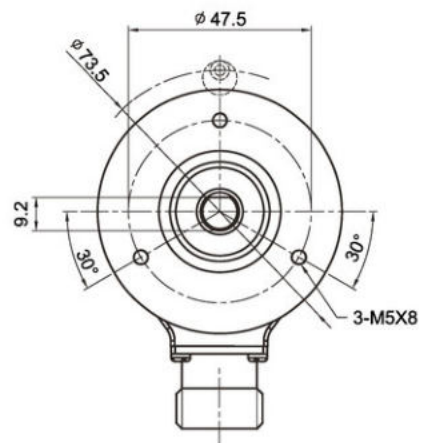
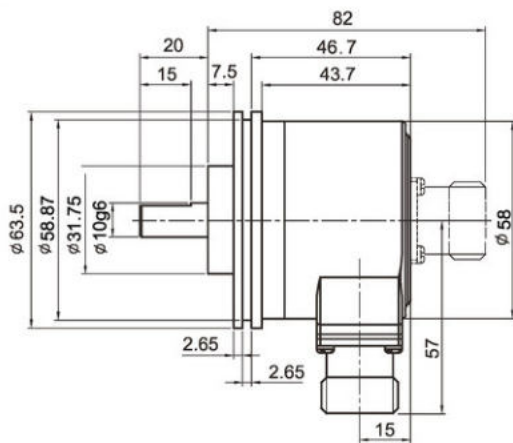

EV58B

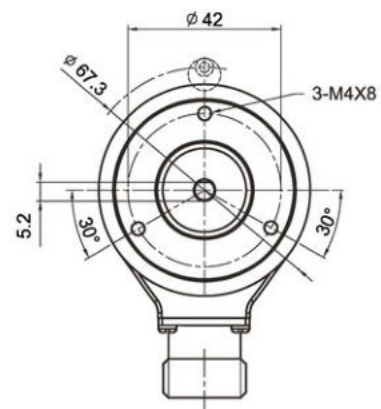
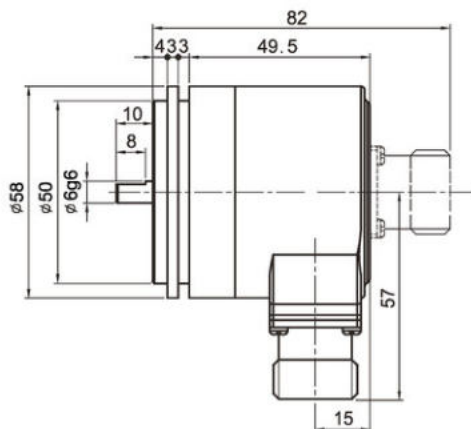

Topydic Series Shaft Incremental Encoder EV58A

Dimensions (mm)

EV58C

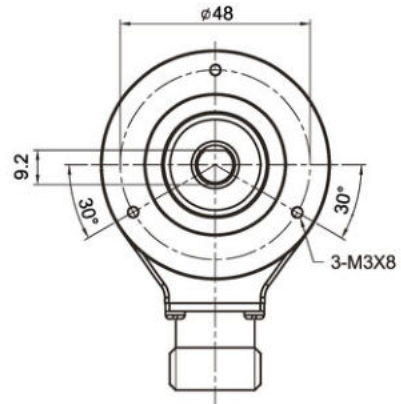
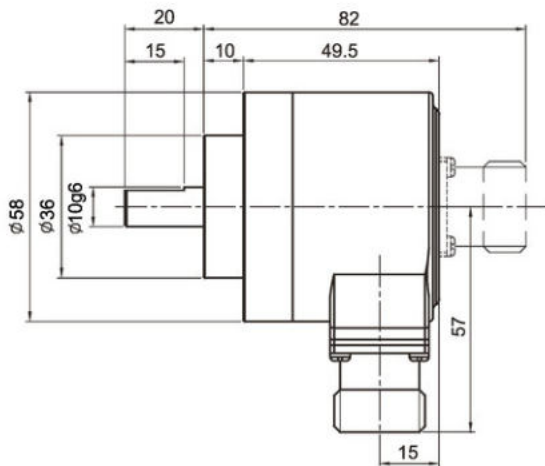

EV58D

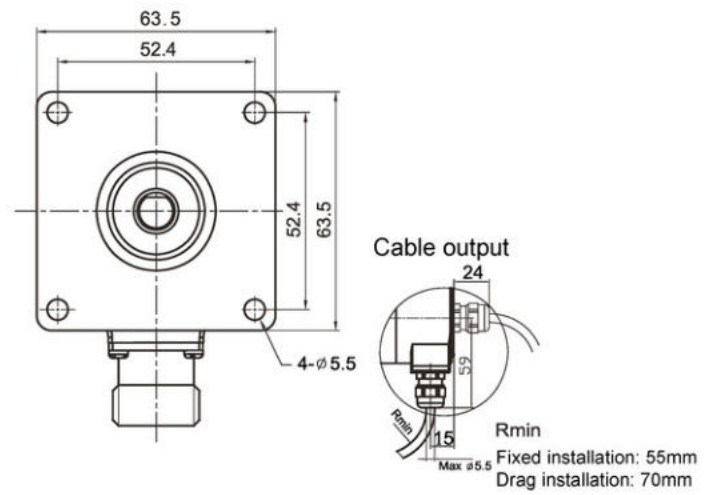
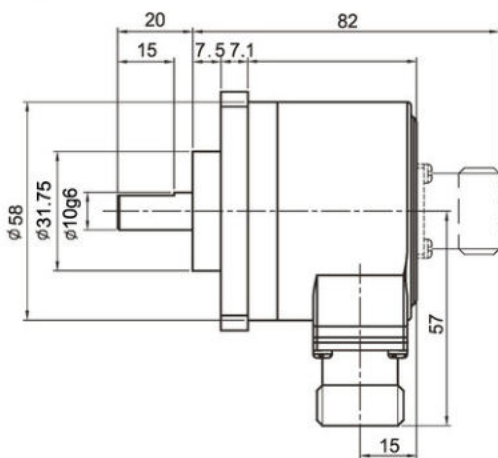

# Topydic Series Shaft Incremental Encoder EV58A

Order Code:

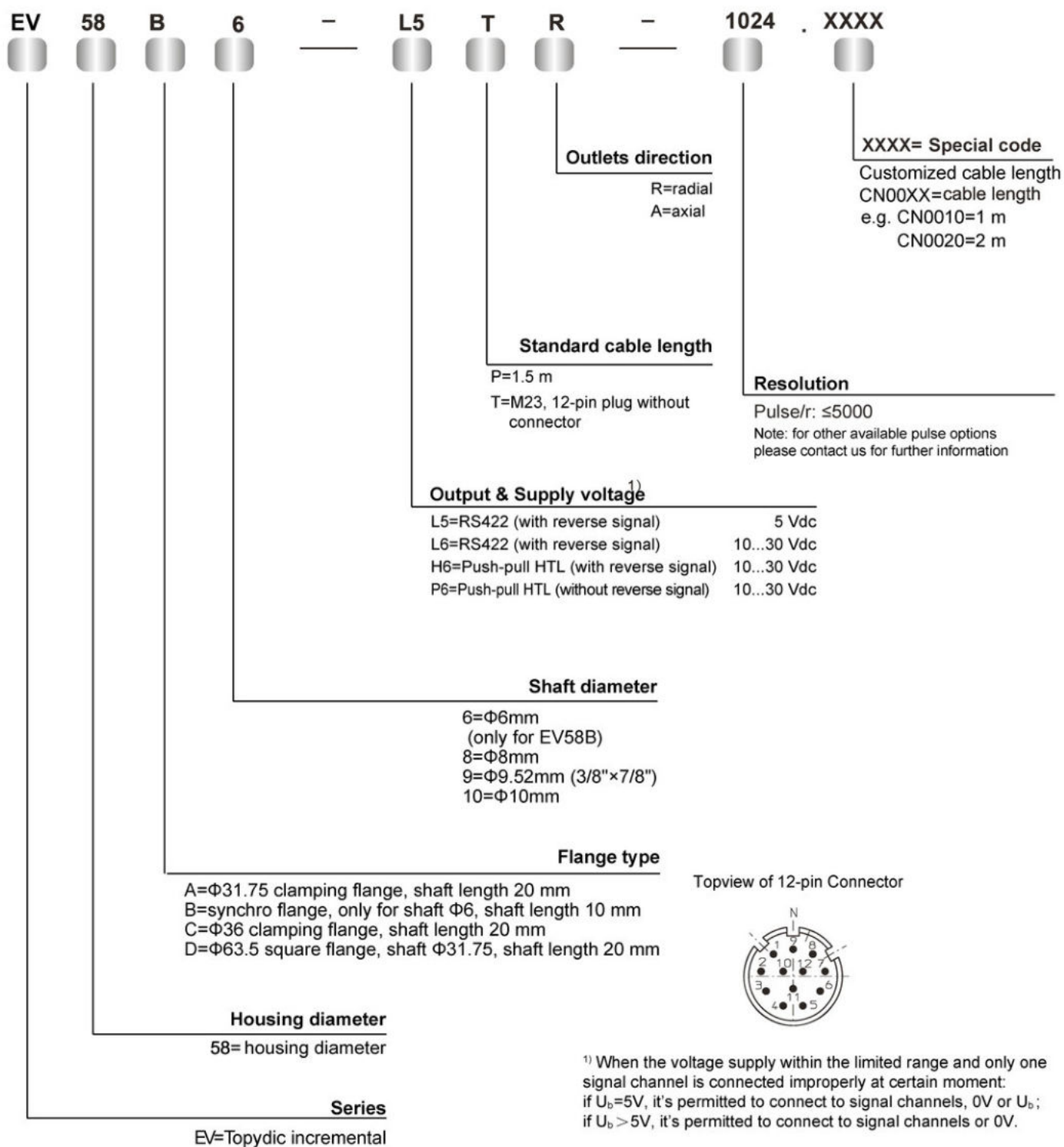

<sup>1)</sup> When the voltage supply within the limited range and only one signal channel is connected improperly at certain moment:  
if  $U_b=5V$ , it's permitted to connect to signal channels, 0V or  $U_b$ ;  
if  $U_b > 5V$ , it's permitted to connect to signal channels or 0V.

Matched connector:  
For connection type "T": TMSP1612F

## Topydic Series Hollow Shaft Incremental Encoder EV58P



### Description

Topydic series encoders EV58P, with double-bearing design, are widely used in industrial environments. It delivers outstanding performance in mechanical shock resistance. It adopts stainless steel hollow shaft design with max. shaft diameter of  $\Phi 15$  mm and is able to withstand higher axial and radial loads. requirements. Its wide voltage range, reverse connection and short circuit protection can effectively avoid mis-wiring.

### Features

- Resolution up to 5000 ppr; pulse frequency up to 300 kHz
- Wide range of shaft diameter,  $\Phi 8 \dots \Phi 15$  mm
- Operating temperature,  $-20 \dots +80$  °C; IP65
- Thickness of 34.5mm, applicable for installation with limited space
- Multi signal output interfaces to meet different types of data acquisition of upper computer
- Reverse connection and short circuit protection to ensure the safety <sup>1)</sup>

### Mechanical Characteristics

Shaft diameter	$\Phi 8 / \Phi 10 / \Phi 12 / \Phi 14 / \Phi 15$ mm
Protection class	IP65
Speed	6000 rpm
Max. load capacity of the shaft	40 N axial
	80 N radial
Shock resistance	50G/11 ms
Vibration resistance	10G 10...2000 HZ
Bearing life	$10^9$ revolution
Moment of inertia	approx. $6 \times 10^{-6}$ kgm <sup>2</sup>
Starting torque	<0.03 Nm
Body material	Al-alloy
Housing material	Al-alloy
Operating temperature	$-20 \dots +80$ °C
Storage temperature	$-40 \dots +95$ °C
Weight	approx. 400 g

Regular resolution: 256, 300, 360, 400, 500, 512, 600, 800, 1000, 1024, 1200, 1250, 2000, 2048, 2500, 3600, 4096, 5000

Attention: the products with above resolutions are available from stock, others on request.

### Electrical Characteristics

Output circuit	RS422	Push-pull
Supply voltage	$5 \pm 0.25$ or $10 \dots 30$ VDC	$10 \dots 30$ VDC
Power consumption (no load)	typ. 40 mA	typ. 50 mA
	max. 90 mA	max. 100 mA
Permissible load	max. $\pm 20$ mA	max. $\pm 30$ mA
Pulse frequency	max. 300 kHz	max. 300 kHz
Signal level high	min. 2.5 VDC	min. $U_b - 1$ VDC
Signal level low	max. 0.5 VDC	max. 0.5 VDC
Rise time Tr	max. 200 ns	max. 1 $\mu$ s
Fall time Tf	max. 200 ns	max. 1 $\mu$ s

<sup>1)</sup> When the voltage supply within the limited range and only one signal channel is connected improperly at certain moment:

if  $U_b = 5$  VDC, it's permitted to connect to signal channels, 0 VDC or  $U_b$ .

if  $U_b > 5$  VDC, it's permitted to connect to signal channels or 0 VDC.

## Topydic Series Hollow Shaft Incremental Encoder EV58P

### Terminal Assignment

Signal	0V	+U <sub>b</sub>	A	$\bar{A}$	B	$\bar{B}$	Z	$\bar{Z}$	Shield
Color Code	WH	BN	GN	YE	GY	PK	BU	RD	±
12-pin	10	12	5	6	8	1	3	4	PH

### Dimensions (mm)

EV58P

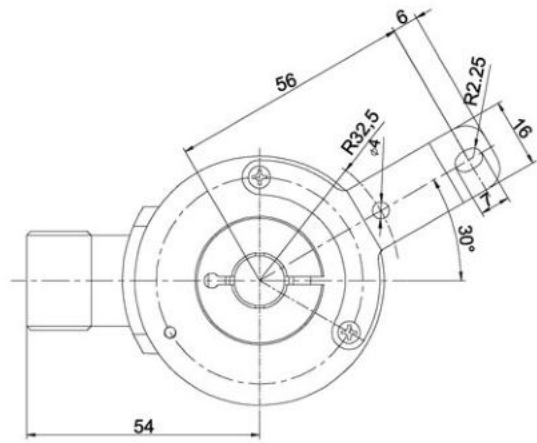
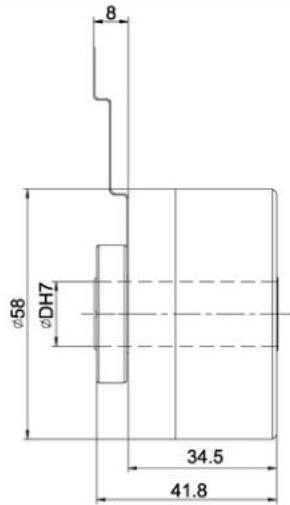

EV58W

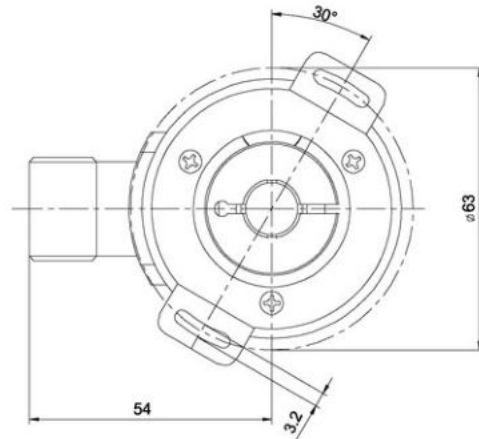
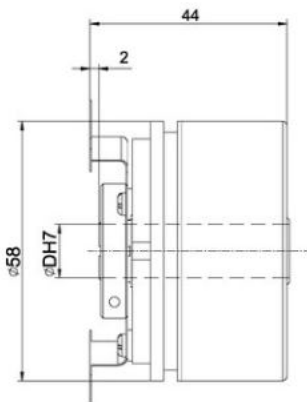

## Topydic Series Hollow Shaft Incremental Encoder EV58P

Order Code:

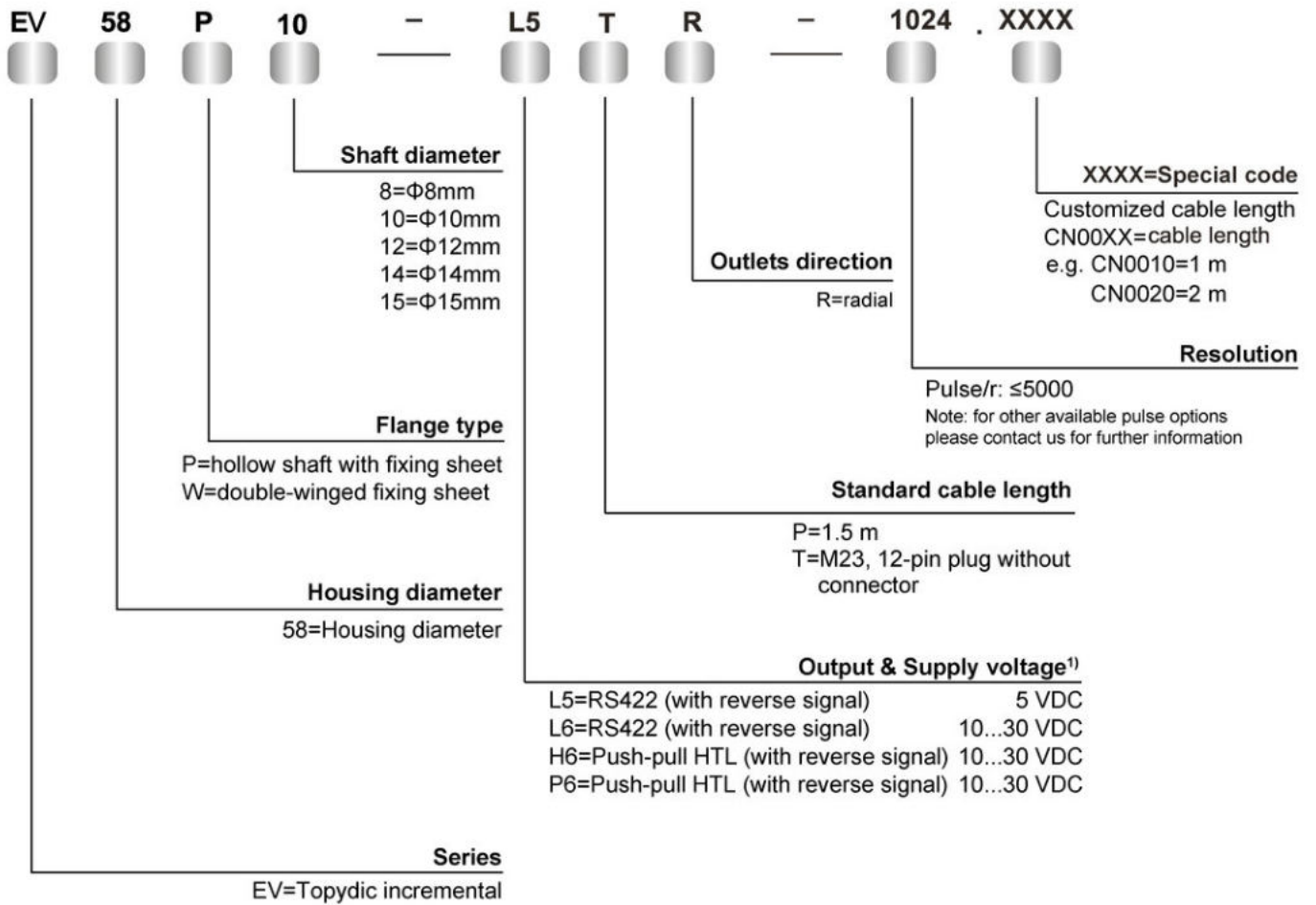

T type connection:  
12-pin M23 Connector

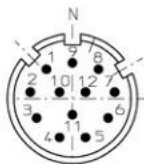

TMSP1612F  
Field attachable connector

<sup>1)</sup>When provided power voltage is correct:  
Short-circuit to channel, 0V, or +U<sub>b</sub> is permitted when U<sub>b</sub> = 5 VDC;  
Short-circuit to channel or 0V is permitted when U<sub>b</sub> = 10...30 VDC

## Heavydic Large Hollow Shaft Incremental Encoder EV90P



### Description

Heavydic large hollow shaft incremental encoder EV90P are specially designed for heavy industries and heavy-loaded shaft applications. It delivers perfect performance of mechanical shock resistance, and is capable of withstanding higher axial and radial loads. It can be directly installed onto the drive shaft with crutch arm or fixing sheet for flexible connection. Its resolution is up to 2500 ppr, which ensures accurate control and application safety.

### Features

- Robust metal housing against greater shock; compact structure for limited installation space
- Resolution up to 2500 ppr; protection class of IP65
- Compact hollow shaft design to save both space and cost
- Crutch arm and fixing sheet provide greater flexibility
- Stainless steel hollow shaft with diameter of  $\Phi 25/\Phi 30/\Phi 38/\Phi 45$ ; installed by "C" lock ring
- Flexible connecting with cable or connector for easy maintenance; water-proof design to ensure safety
- Reverse connection / short circuit protection<sup>1)</sup>

### Mechanical Characteristics

Hollow shaft diameter	$\Phi 25/\Phi 30/\Phi 38/\Phi 45$ H7 mm
Protection class	IP65
Speed	3500 rpm
Max. load capacity of the shaft	80 N axial 140 N radial
Shock resistance	50G/11 ms
Vibration resistance	10G 10~2000 HZ
Bearing life	$10^9$ revolution
Moment of inertia	approx. $15 \times 10^{-6}$ kgm <sup>2</sup>
Starting torque	<0.1Nm with oil seal
Body material	Al-alloy
Housing material	Al-alloy
Operating temperature	-20~+80 °C (-40~+80 °C optional)
Storage temperature	-45~+85 °C
Weight	approx. 900 g

Regular resolution: 1024, 2048

Attention: the products with above resolutions are available from stock, others on request.

### Electrical Characteristics

Output circuit	RS422	Push-pull
Resolution	Max 2500 ppr	Max 2500 ppr
Supply voltage	5±0.25 or 10...30 VDC	10...30 VDC
Power consumption (no load)	≤80 mA	≤125 mA
Permissible load	±20 mA	±40 mA
Pulse frequency	Max 300 kHz	Max 300 kHz
Signal level high	Min 3.4 V	Min $U_b - 1.8$
Signal level low	Max 0.4 V	Max 2.0 V
Rise time Tr	Max 200 ns	Max 1 μS
Fall time Tf	Max 200 ns	Max 1 μS

### Terminal Configuration

Signal	0V	+U <sub>b</sub>	A	$\bar{A}$	B	$\bar{B}$	Z	$\bar{Z}$	Shield
Color Code	WH	BN	GN	YE	GY	PK1	BU	RD	⊥
Pin	10	12	5	6	8	1	3	4	PH

- 1) When the voltage supply within the limited range and only one signal channel is connected improperly at certain moment:  
 if  $U_b = 5$  V, it's permitted to connect to signal channels, 0 V or  $U_b$ ;  
 if  $U_b > 5$  V, it's permitted to connect to signal channels or 0V.

Matched connector:  
 the compatible connector with type of connection "T" is TMS1612F.

Topview of 12-pin plug

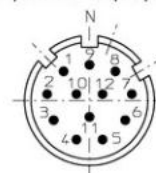

## Heavydic Large Hollow Shaft Incremental Encoder EV90P

### Dimensions (mm)

EV90P

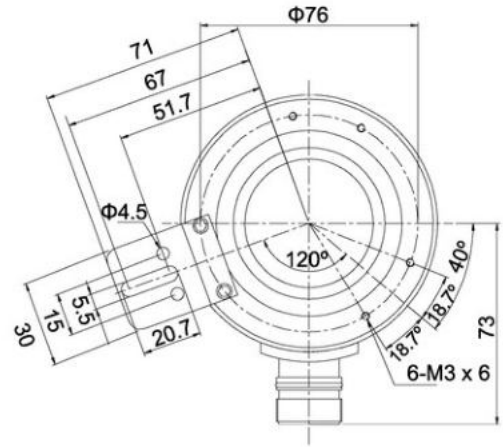
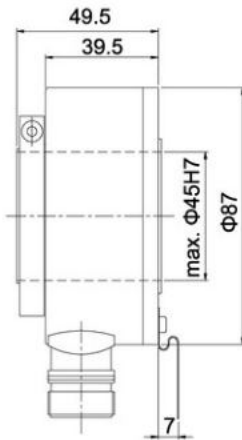

EV90R

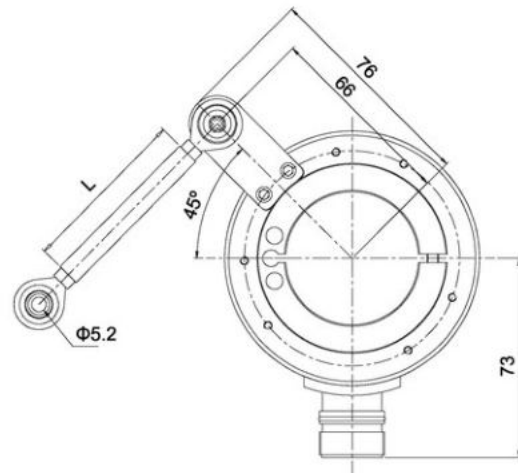
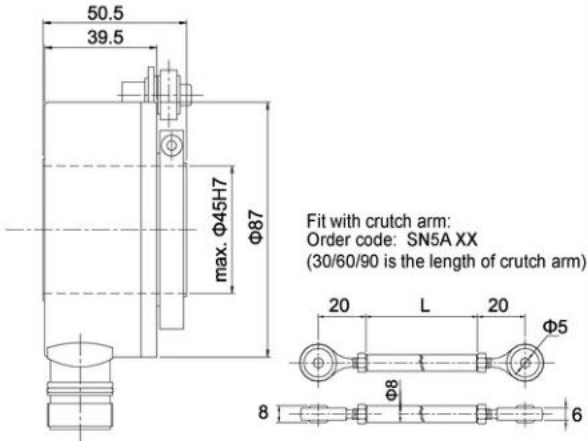

### Order Code:

EV 90 P 30 - L5 T R - 1024 . XXXX

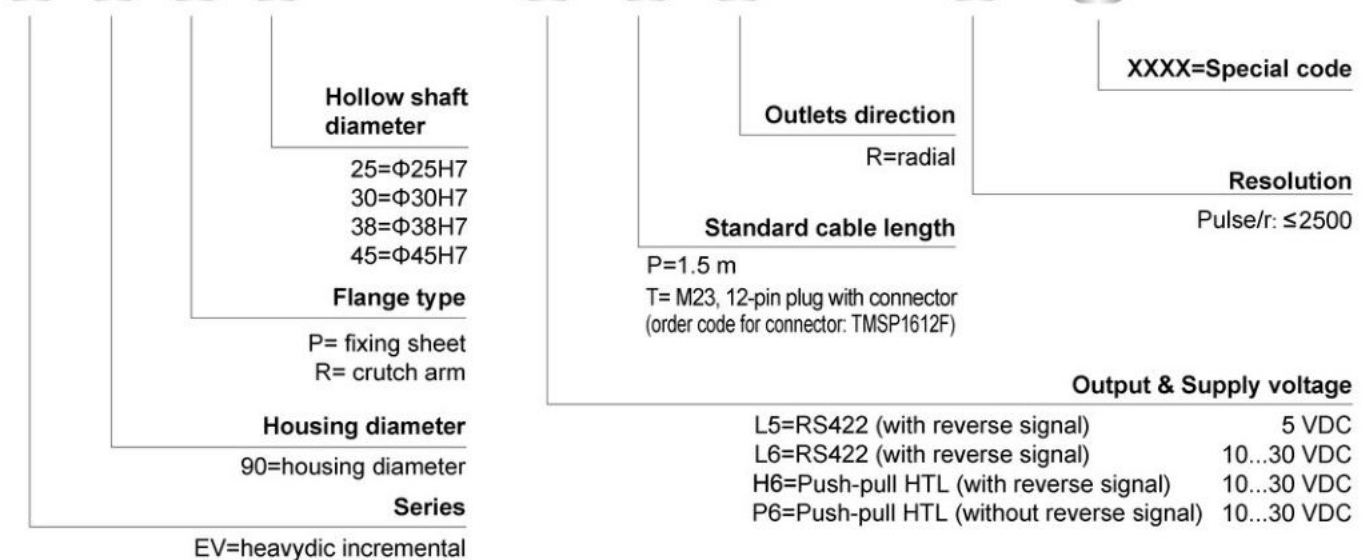

## Topydic Series Large Hollow Shaft Incremental Encoder EV150P



### Description

Topydic series large hollow shaft encoders EV150P are widely used in industrial environments in which direct installation on the drive shaft for speed feedback is required. It delivers excellent performance in withstanding mechanical shock and higher axial and radial loads. Hollow shaft structure could be directly installed onto the drive shaft, and crutch arm or block-pin accessories provide greater flexibility to prolong the usability of the encoder. EV150P delivers resolution up to 2048 ppr, and guarantees both precise measurement control and safety in loading. It is the most recommended product for its high quality and affordability.

### Features

- Crutch arm or block-pin accessories provide the greatest flexibility
- Resolution 2048 ppr, IP64 guarantees precision and safety
- Compact hollow shaft design is both a space and cost-saver
- Metal housing for greater shock resistance, compact structure is suited for confined mounting space
- Stainless steel hollow shaft  $\Phi 60H7 - \Phi 80H7$ , "C" lock ring
- Cable output or connector is flexible and easy for maintenance  
The waterproof rubber ends ensures safety
- Reverse connection protection and short circuit protection

### Mechanical parameters

Hollow shaft diameter	$\Phi 60H7 - \Phi 80H7$ mm
Protection class	IP64
Speed	3000 rpm
Max load capacity of the shaft	100 N axial 200 N radial
Shock resistance	50G/11 ms
Vibration resistance	10 G 10~2000 Hz
Bearing life	$10^9$ revolution
Moment of inertia	$<15 \times 10^{-6}$ kgm <sup>2</sup>
Starting torque	$<0.25$ Nm max.
Body material	AL-alloy
Housing material	AL-alloy + green paint
Operating temperature	-20~+90 °C
Storage temperature	-40~+100 °C
Weight	1800 g

Resolution: 1000, 1024, 2048

Attention: the products with above resolutions are available from stock, others on request.

### Electrical parameters

Output circuit	RS422	Push-pull
Resolution	Max.2048 ppr	Max.2048 ppr
Supply voltage	5±0.25 or 10...30 VDC	10...30 VDC
Power consumption (no load)	≤80 mA	≤125 mA
Permissible load (channel)	±50 mA	±80 mA
Pulse frequency	Max.800 kHz	Max.800 kHz
Signal level high	Min.3.4 V	Min.Ub-1.8
Signal level low	Max.0.4 V	Max.2.0 V
Rise timeTr	Max 200 ns	Max 1 μs
Fall timeTf	Max 200 ns	Max 1 μs

### Terminal Assignment

Signal	0V	+U <sub>b</sub>	A	$\bar{A}$	B	$\bar{B}$	Z	$\bar{Z}$	Shield
Color	WH	BN	GN	YE	GY	PK	BU	RD	⊥
Pin	10	12	5	6	8	1	3	4	PH

## Topydic Series Large Hollow Shaft Incremental Encoder EV150P

### Dimensions (mm)

EV150P  
Double-wing fixing plate  
E41350013

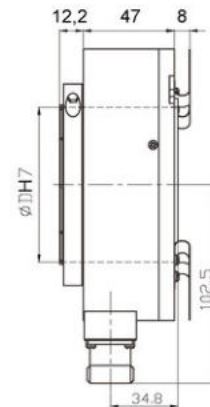
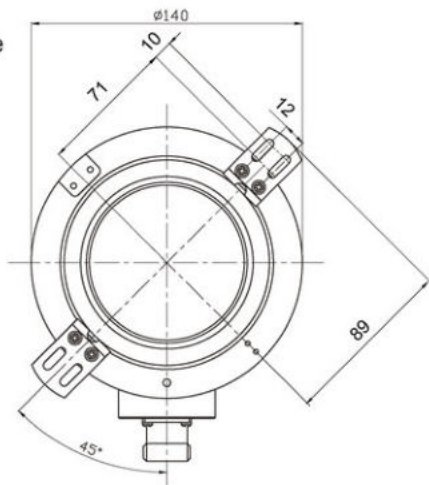

EV150K  
Long torque support slot:  
E41350035  
Block pin:  
E41220002

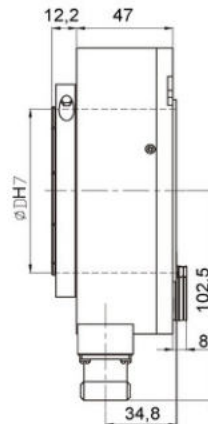
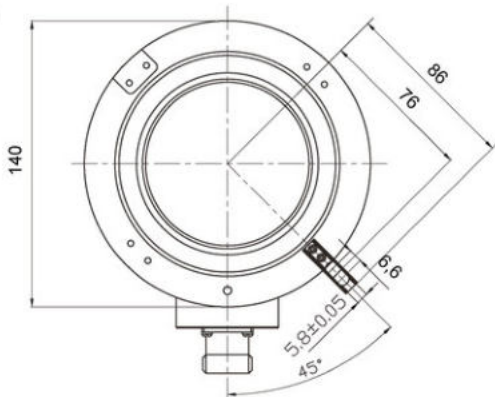

Cable output

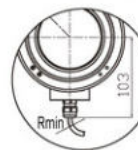

Rmin  
Fix installation: 55mm  
Draw installation: 70mm

EV150R  
Torque arm SN5A60

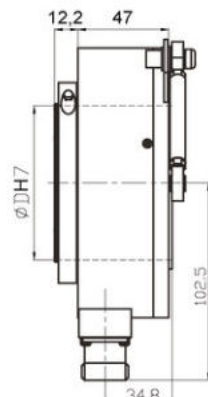
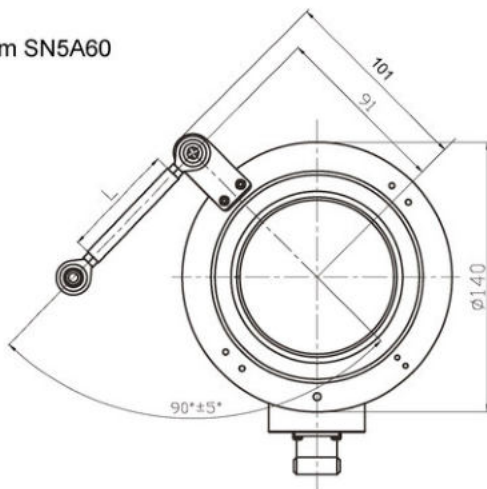

Crutch arm order  
SN5A XX  
(30,60,90 means length)

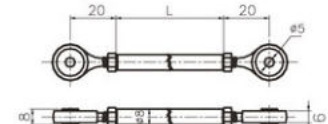

# Topydic Series Large Hollow Shaft Incremental Encoder EV150P

## Dimensions (mm)

EV150H  
Tether arm large  
E41350059

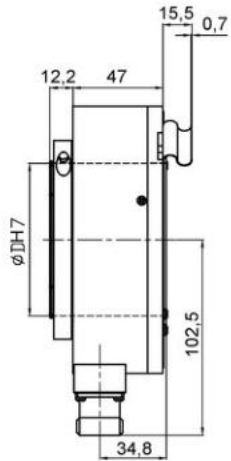
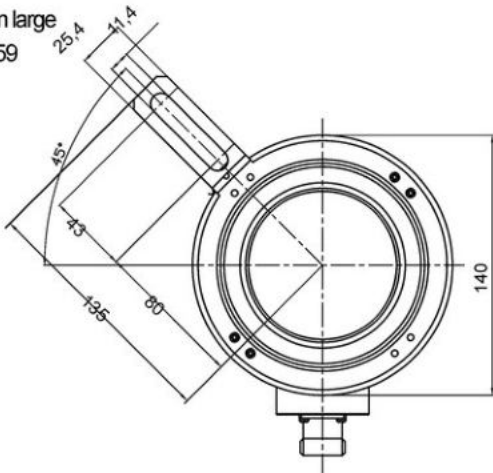

EV150RP  
Double-wing fixing plate  
E41350013

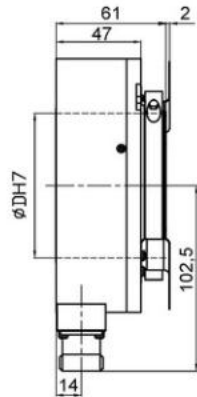
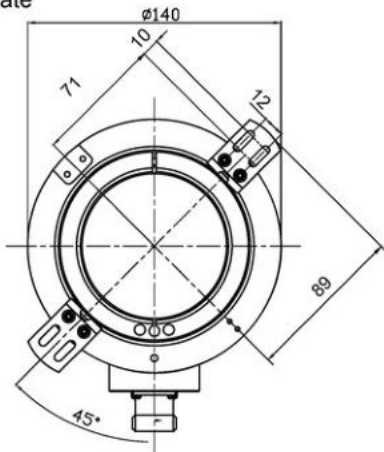

EV150RK  
Long torque support slot: E41350035  
Block pin: E41220002

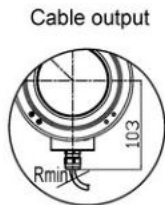
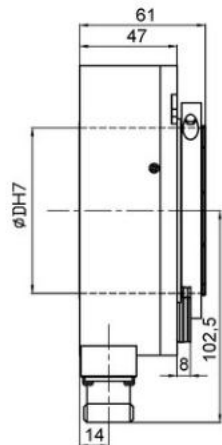
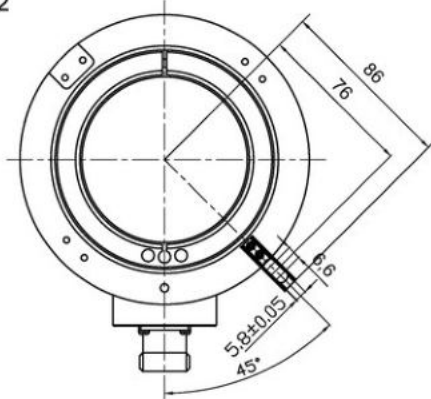

Rmin  
Fix installation: 55mm  
Draw installation: 70mm

## Topydic Series Large Hollow Shaft Incremental Encoder EV150P

### Dimensions (mm)

EV150RR  
Torque arm SN5A60

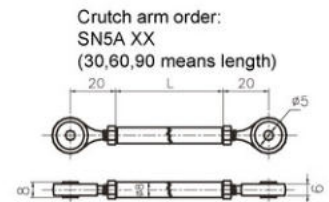
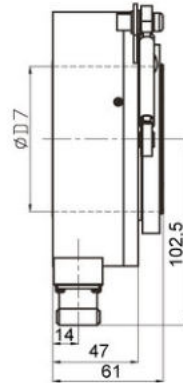
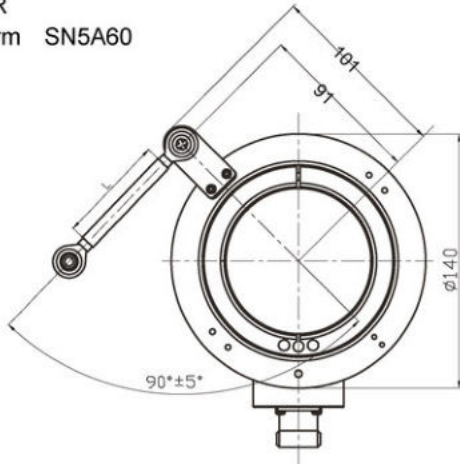

EV150RH  
Tether arm large  
E41350059

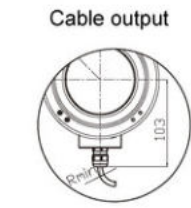
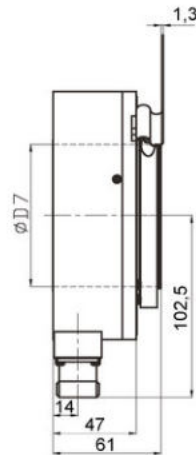
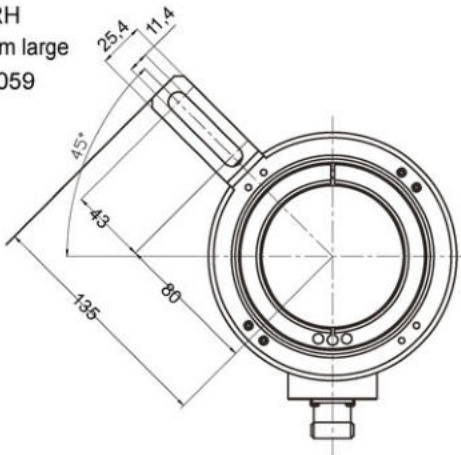

Rmin  
Fix installation: 55mm  
Draw installation: 70mm

### Keyway shaft

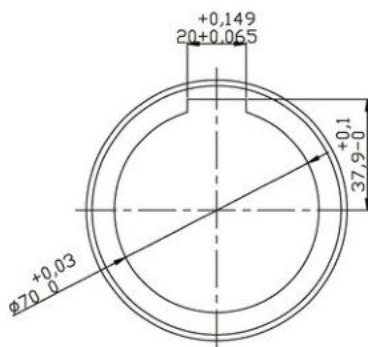

EV150P Keyway

# Topydic Series Large Hollow Shaft Incremental Encoder EV150P

Order Code:

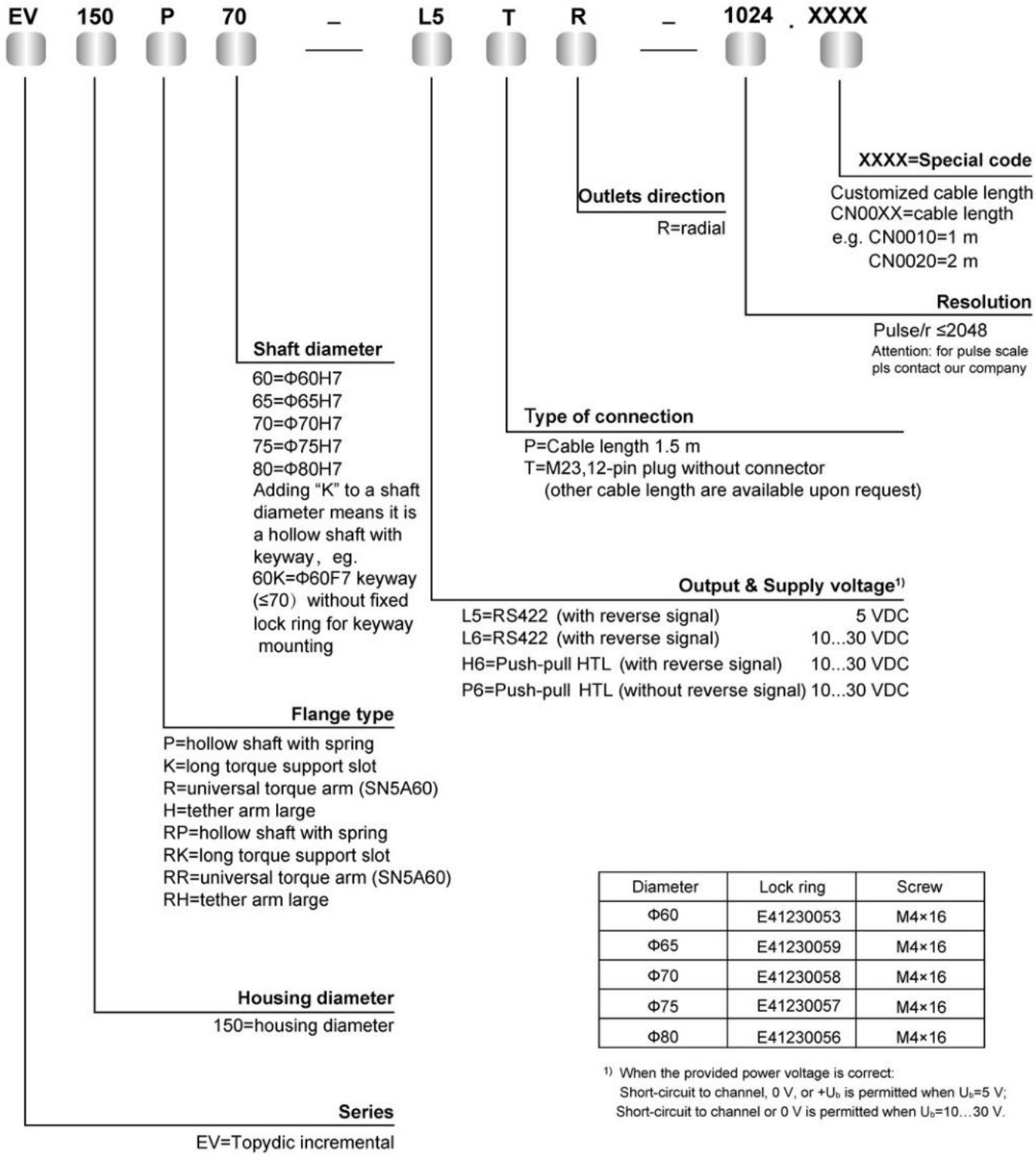

## EVL Support

**EVL support:**

Type: EVL-L38A  
 Material: carbon steel  
 Surface treatment: zinc plating  
 Applicable for: shaft encoder 38 series  
 Installation: with flange

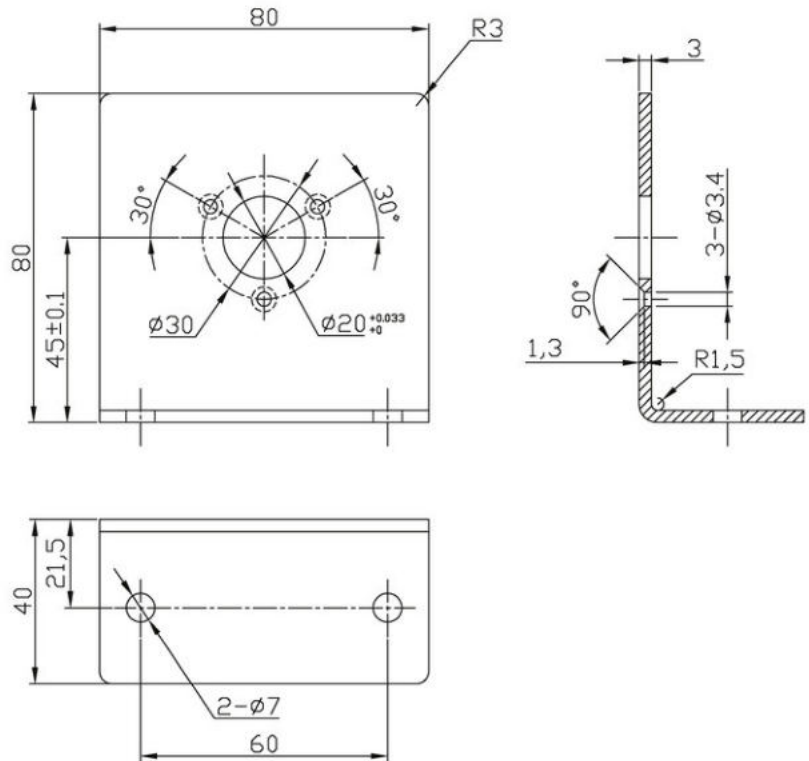

**EVL support:**

Applicable for shaft encoder 40 with clamping flange  
 Material: Al  
 Type:  
 EVL-L40A

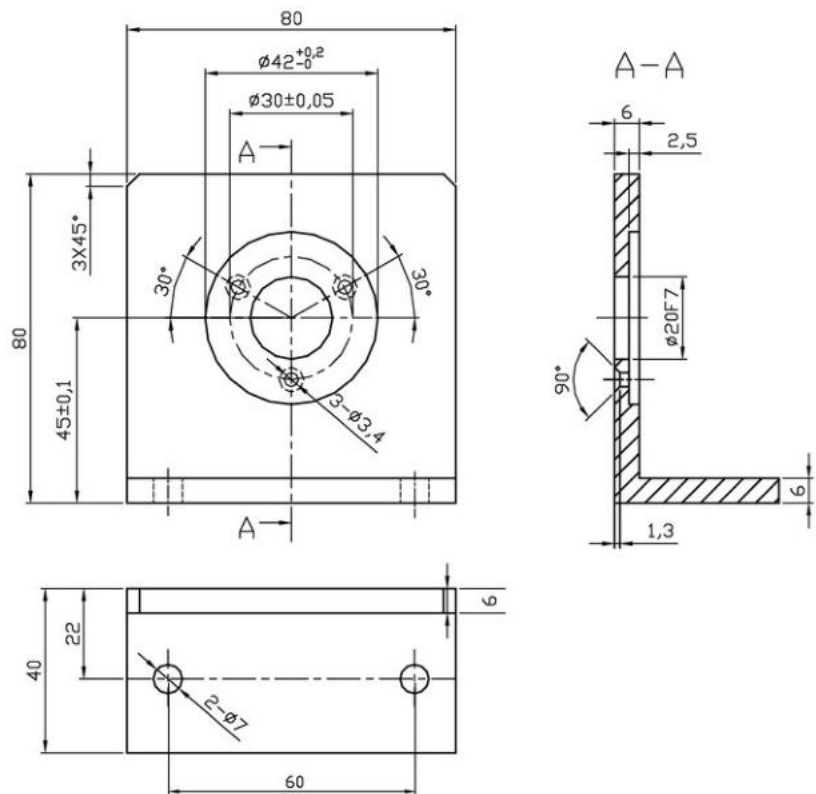

## EVL Support

**EVL support:**

Applicable for shaft encoder 50A with clamping flange

Material: Al

Type:  
EVL -L50A

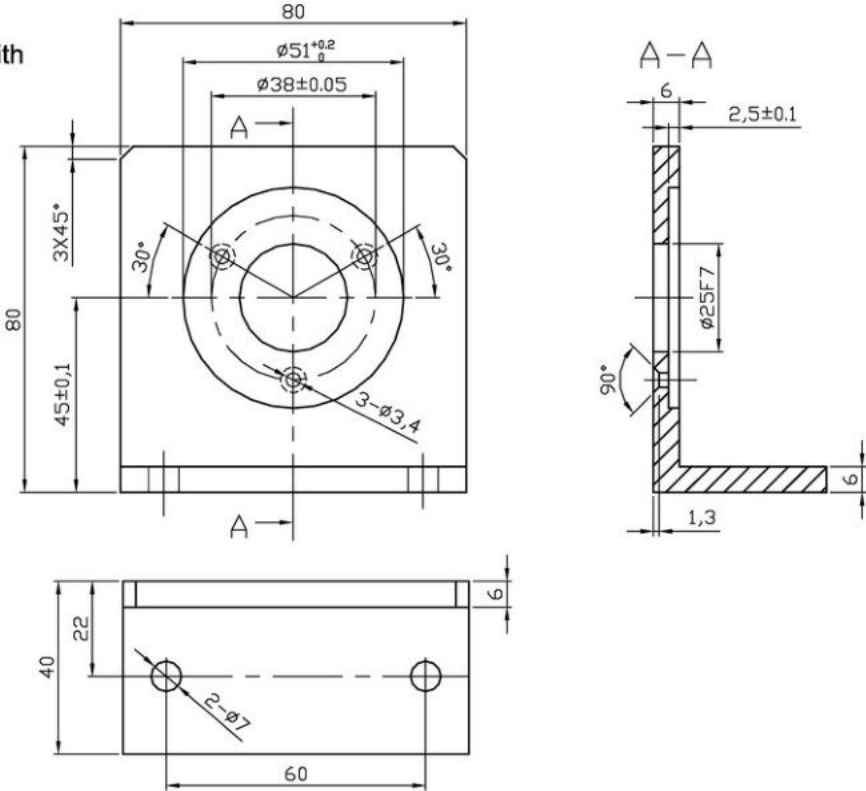

**EVL support:**

Applicable for shaft encoder 58A with clamping flange

Material: Al

Type:  
EVL-L58A

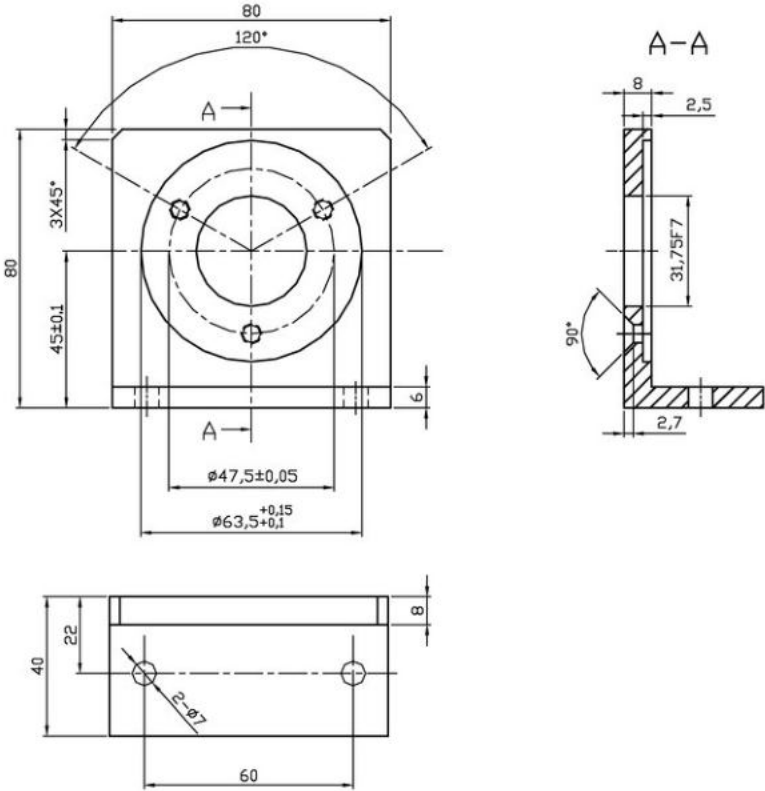

## EVL Support

### EVL support:

Applicable for shaft encoder 58 with clamping flange

Material: Al

Type:  
EVL-L58C

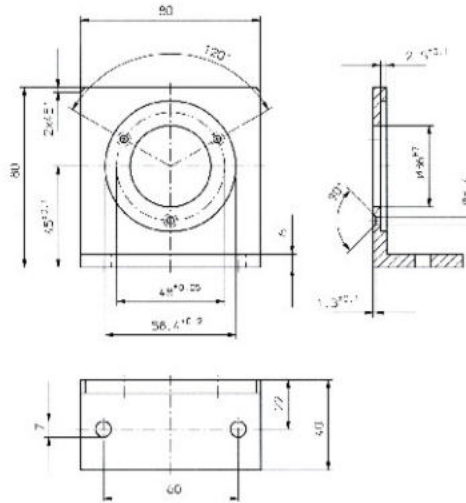

### EVL support:

Applicable for shaft encoder 90 with clamping flange

Material: Al

Type:  
EVL-L90A

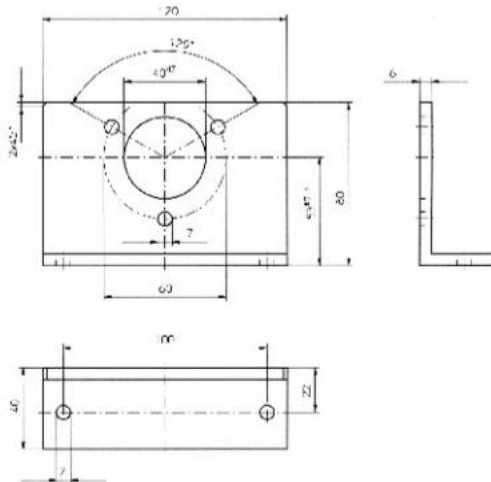

### EVL support:

Applicable for shaft encoder 115 with clamping flange

Material: Al

Type:  
EVL-L115A

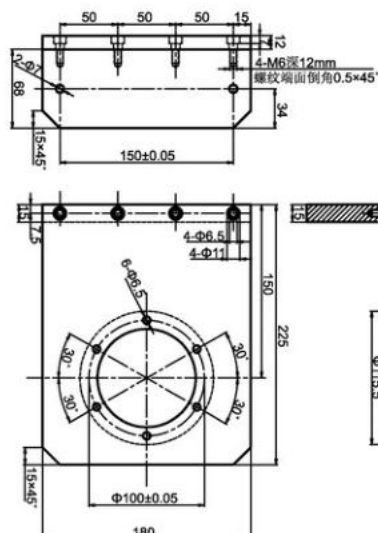

## Coupling



### Description:

Flexible precision couplings are essential parts for the transmission of rotational motion to the encoder shaft. Couplings are designed in AL-alloy and are composed by a cylindrical body on which there is a helicoidal groove. With the perfect balancing of the rotating body, the couplings do not have critical points subject to breakage and are completely frictionless. Moreover, they perfectly transmit the rotation motion, even in the case of axial misadjustment and misalignment. The couplings do not require any maintenance. The internal drain allows the coupling to have the minimum distance of 6.12 mm between the shafts.

### Features:

- Torsional rigidity
- Ability to support slight shaft misadjustments
- Ability to absorb small axial shift of the shaft

Note: Metric and Imperial sizes: A1=6.35 mm A2=9.525 mm A3=12.7 mm

### Screw flexible coupling:

Code	$\Phi d1/\Phi d2$ Shaft diameter	$\Phi D$	L	L1	Twisting moment	Max. angular displacement	Max. speed	Screw (M)	Material
EBG20/20A□□□□	3 4 5 6 6.35(A1)	20	20	2.55	0.8 N.m	1°	8000 r/min	M3	AL-alloy
EBG25/25A□□□□	5 6 6.35(A1) 8 9.525(A2) 10	25	25	3.55	1.8 N.m	1°	8000 r/min	M4	AL-alloy
EBG30/30A□□□□	6 8 9.525(A2) 10 12 12.7(A3)	30	30	4.15	2.7 N.m	1°	8000 r/min	M5	AL-alloy
EBG38/38A□□□□	8 9.525(A2) 10 12 12.7(A3) 14 15	38	38	4.15	6.3 N.m	1°	8000 r/min	M5	AL-alloy
EBG50/50A□□□□	12 12.7(A3) 14 15 16 18 19	50	50	5.25	19.5 N.m	1°	8000 r/min	M6	AL-alloy

### Coupling Dimensions:

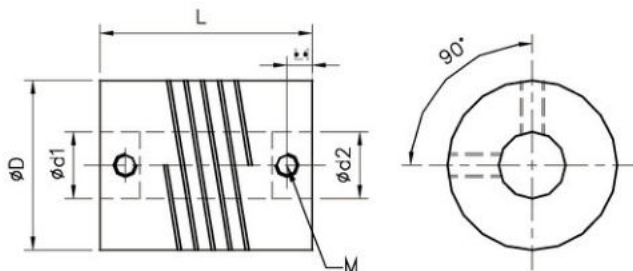

### Order Code

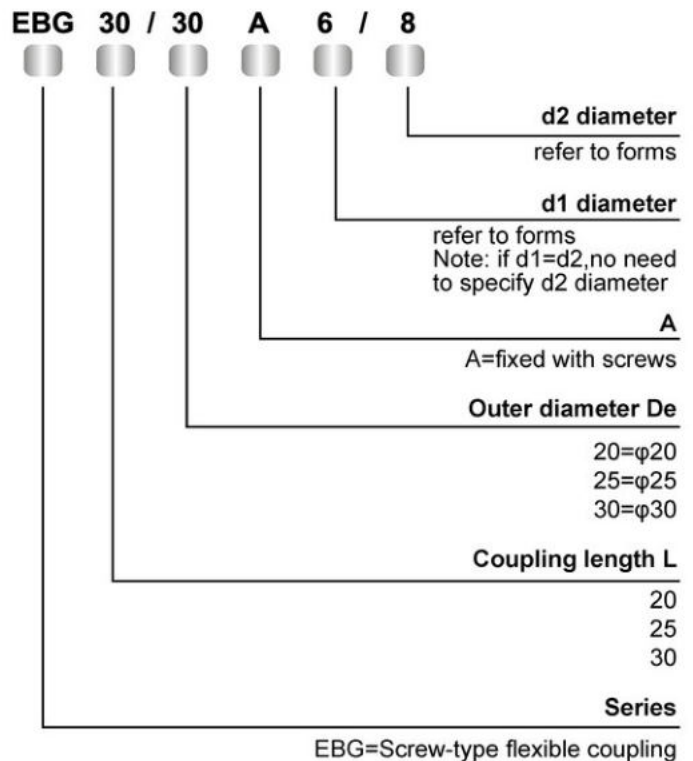

## Coupling

### Bellow flexible coupling

Code	$\Phi d1/\Phi d2$ Shaft diameter	$\Phi D$	L	L1	F	E	Twisting moment	Max. angular displacement	Max. speed	Screw (M)	Material
ECS27/16A □□□□	4 5 6 6.35(A1) 8	16	27	8.5	3	9.5	0.5 N.m	2°	6000 r/min	M3	AL-alloy
ECS29/20A □□□□	5 6 6.35(A1) 8 9.525(A2) 10 12	20	29	8.5	3	12.5	0.6 N.m	2°	6000 r/min	M3	AL-alloy
ECS34/25A □□□□	6 6.35(A1) 8 9.525(A2) 10 12	25	34	10.5	4	15	1.7 N.m	2°	6000 r/min	M4	AL-alloy
ECS38/32 □□□□	6 8 9.525(A2) 10 12	32	38	11.5	4	21	1.7 N.m	2°	6000 r/min	M4	AL-alloy
ECS49/32 □□□□	6 8 9.525(A2) 10 12	32	49	11.5	4	21	1.7 N.m	2°	6000 r/min	M4	AL-alloy
ECS51/40 □□□□	10 11 12 14 15 16	40	51	12.5	4.5	27	3.5 N.m	2°	6000 r/min	M5	AL-alloy
ECS57/55A □□□□	12 14 15 16	50	57	13.5	5	40	9.0 N.m	2°	6000 r/min	M6	AL-alloy

### Coupling Dimensions

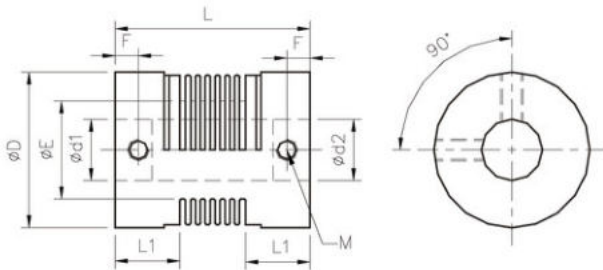

### Order Code

**ECS 49 / 23 A 10 / 12**

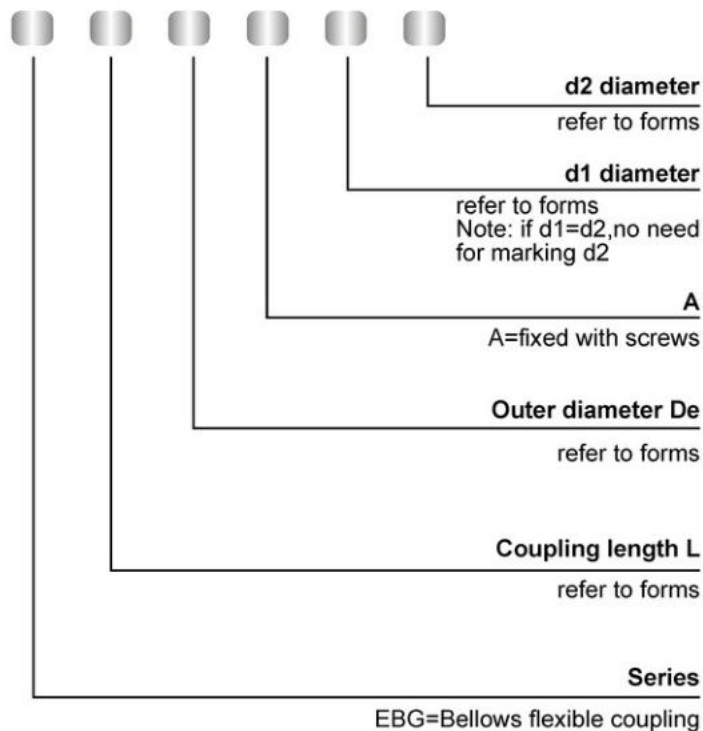

## Compact absolute multiturn encoder EMM36



### Description:

EMM36 series of compact multiturn encoder with outer diameter of only 36 mm, The product uses stable magnetic chip technology, single-turn resolution is 12 bits, the maximum revolution can be achieved 12 bits, a variety of communication interface can be chosen, widely used in logistics, packaging machinery and machinery manufacturing industries.

### Features:

- Stable magnetic chip technology can provide multiple communication interfaces.
- Metal casting housing can bear higher radial force and axial force.
- Protection class IP65
- Output cable or connector available for easy maintenance
- Customized -40 °C products for environmental applications

### Mechanical parameters:

Shaft diameter(mm)	Φ6h6
Protection class	IP65
Max.speed	6000 rpm
Max.load capacity of shaft	20 N (axial) 80 N (radial)
Shock resistance	100 G/6ms
Vibration resistance	20G 100...2000 Hz
Bearing life	10 <sup>9</sup> revolution
Moment of inertia	2.5×10 <sup>-6</sup> kgm <sup>2</sup>
Starting torque	<0.01 Nm
Body material	Al-alloy
Housing material	Al-alloy
Operating temperature	-40...+80 °C
Storage temperature	-45...+85 °C
Weight	About 400 g (except cable)

### Electrical parameters:

Output circuit	SSI
Output driver	RS422
Single turn resolution	12 bits
Revolution	12 bits
Supply voltage	10...30 VDC
Power consumption (no load)	Max. 200 mA
Maximum load current	±20mA
Output frequency	Max. 15 KHz
Signal level high	Typ. 3.8 V
Signal level low	Max. 0.5 V
Rise time Tr	Max. 100 ns
Fall time Tf	Max. 100 ns

Interface	CANopen Profile DSP 406 with additional function
Profile	CAN HIGH-Speed to ISO/DIS 1898, Basic and Full-CAN
	CAN specification 2.0B
Code	Binary
Linearity	±1/2 LSB (12bits), ±1LSB(13bits)
Baud rate	20...800 Kbits/s (Pre-factory setting)
Single turn resolution	12 bits
Revolution	12 bits
Supply voltage	10...30 VDC
Maximum load current	Max.290 mA
Programming Functions	Resolution, preset, counting direction

## Compact absolute multiturn encoder EMM36

### Terminal Assignment

#### SSI

Signal	0V	+U <sub>b</sub>	+C	-C	+D	-D	ST	V/R	Shield
Color	WH	BN	GN	YE	GY	PK	BU	RD	⊥
8-pin	1	2	3	4	5	6	7	8	Housing

#### Canopen

Signal	0V	+Ub	RESET	CAN_H	CAN_L
Color	WH	BN	BU	GN	GY
5-pin	3	2	1	4	5

RESET: Set +24V for 2 seconds, encoder restore factory Settings  
 The factory baud rate of the encoder is set to 250K,  
 the communication ID is set to NODE ID=32, and the cycle time is 100ms.

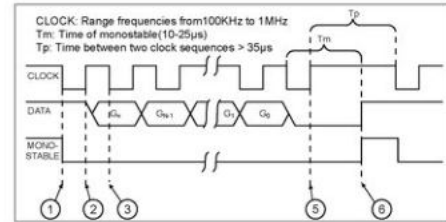

ST: reset input and store the current position value as new zero bit.  
 V/R: Up/Down input, this input triggers, when the encoder axis rotates clockwise, the output value decreases.

### Dimensions(mm)

#### 36A Radial

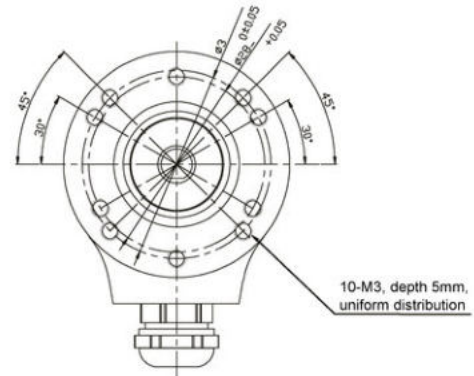
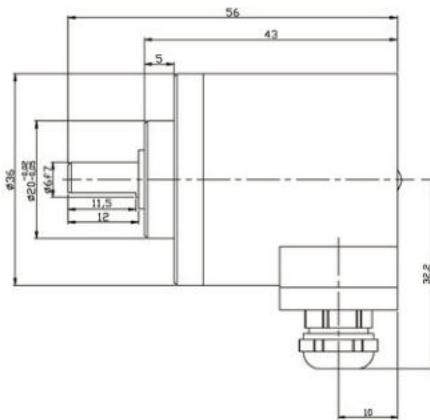

#### 36A Axial

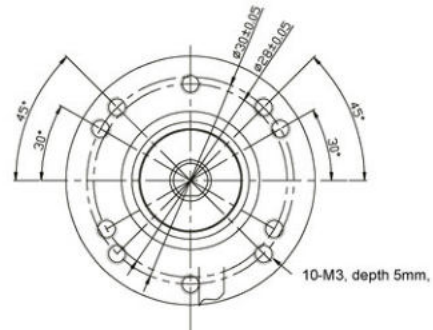
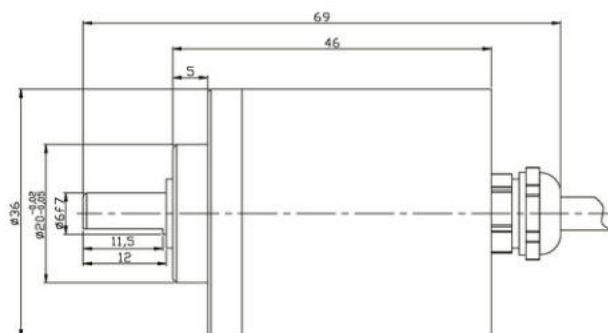

# Compact absolute multiturn encoder EMM36

36A M5/M8 Axial

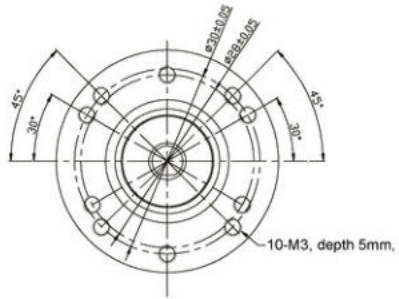
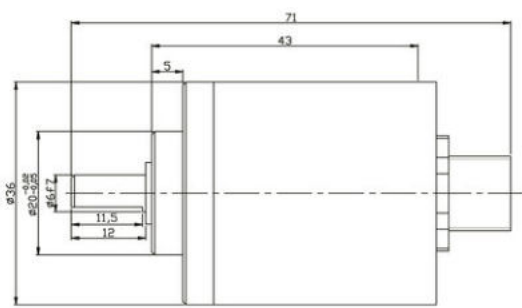

36A M5/M8 Radial

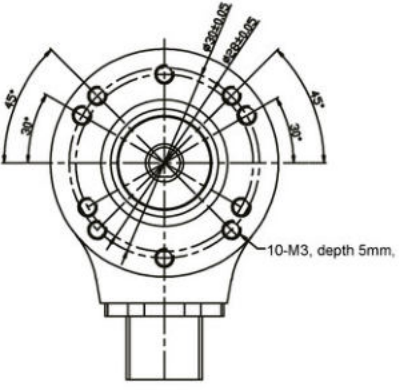
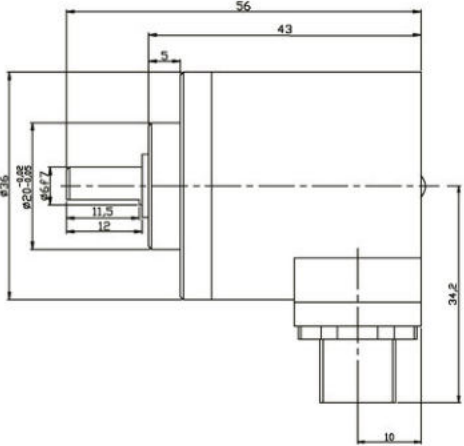

36W Radial

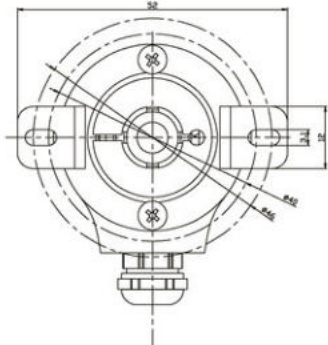
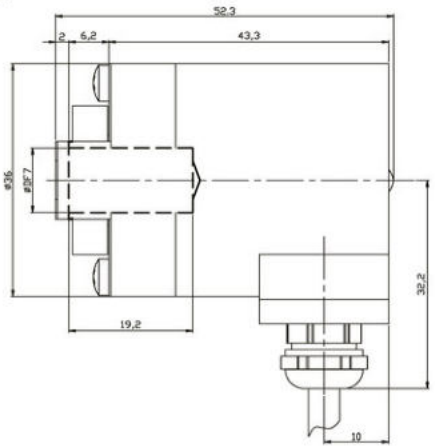

Compact absolute multiturn encoder EMM36

36W M5/M8 Radial

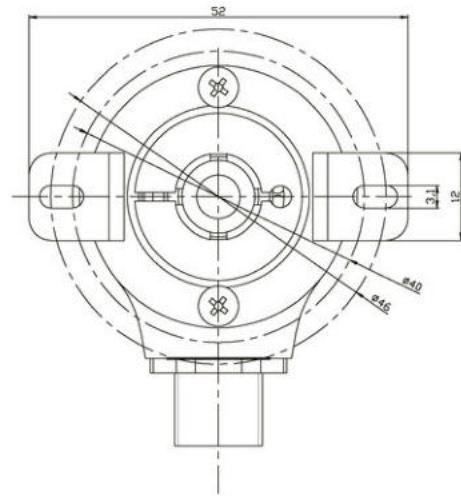
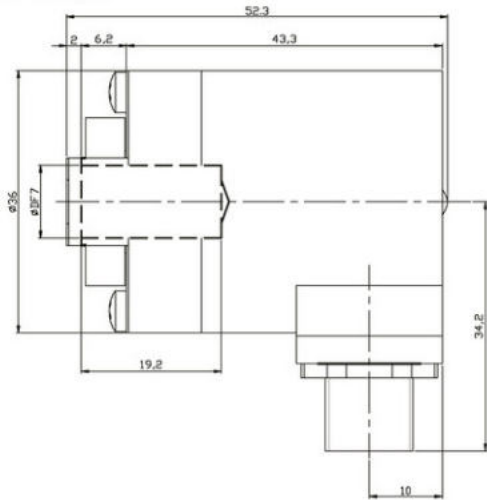

36W M5/M8 Axial

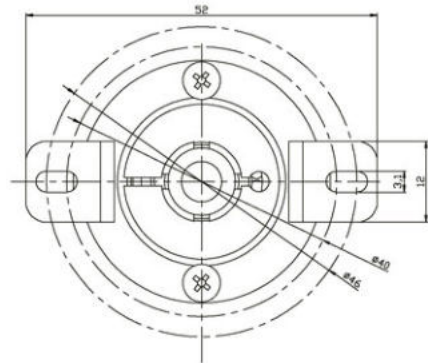
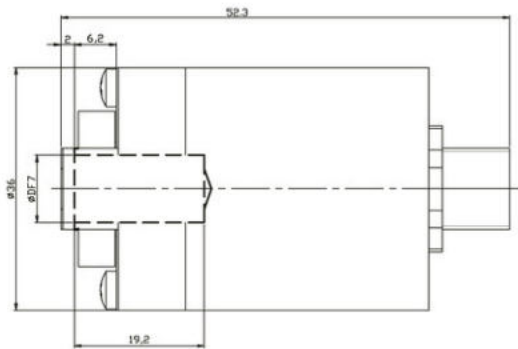

36W Axial

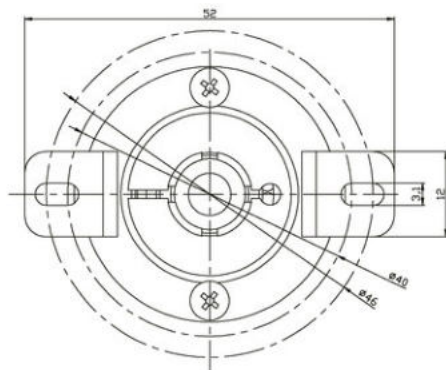
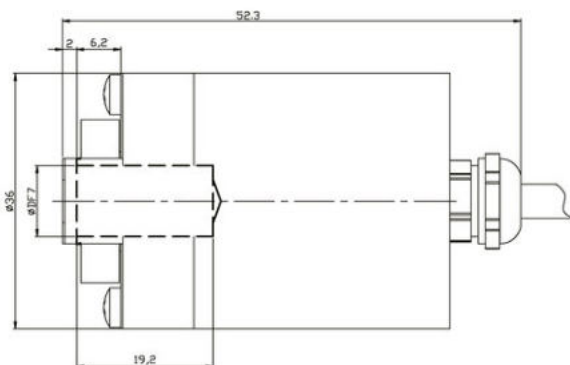

# Compact absolute multiturn encoder EMM36

Order Code:

EMM 36 A 6 - G S6 X PC R - 4096/4096.EUND

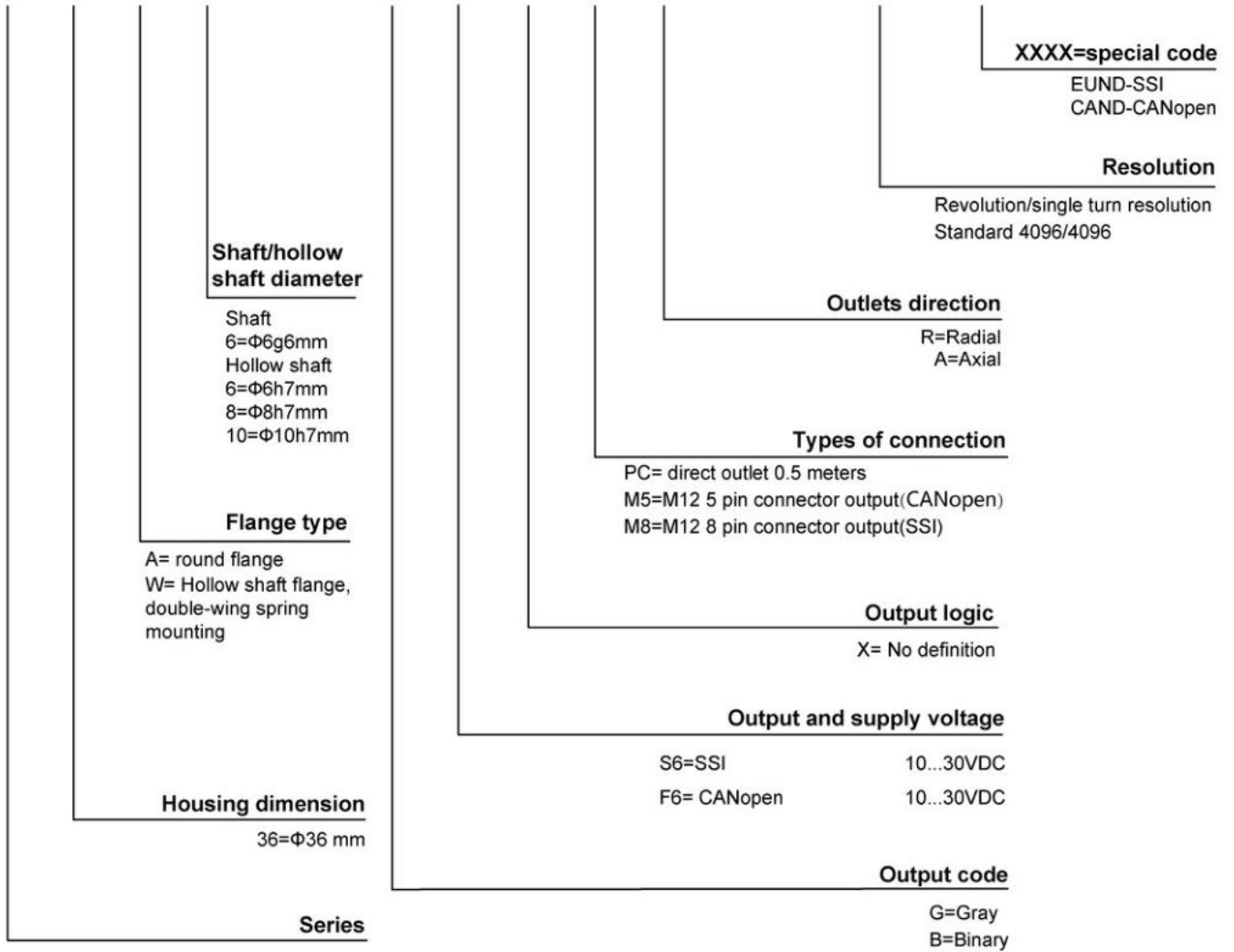

## Miniature Absolute Singleturn Encoder EAC50



### Description

Miniature absolute singleturn encoder EAC50 series can withstand a higher axial and radial load with its reasonable and compact structure. The standard flange combines the clamping and synchronous flanges together, while leaving multiple types of pre-screwed holes for easy installation. The EAC50 series can be widely used in angular and positioning measurement, particularly in the textile industry.

### Features

- Pre-screwed holes for easy installation
- Clamping and synchronous flanges combined
- Durable stainless steel shaft
- Metal housing for shock resistance
- Waterproof metal wiring for greater IP level
- Protection class IP64
- Reverse connection protection

### Mechanical parameters

Shaft diameter	Φ6g6/Φ8g6 mm
Protection class	IP64
Speed	6000 rpm
Max load capacity of the shaft	
Axial load capacity	40 N
Radial load capacity	80 N
Shock resistance	50G/11 ms
Vibration resistance	10G 10~2000 Hz
Bearing life	10 <sup>9</sup> revolution
Rotor moment of inertia	1.8×10 <sup>-6</sup> kgm <sup>2</sup>
Starting torque	<0.01 Nm
Body material	AL-alloy
Housing material	AL-alloy
Operating temperature	-20℃ ~+80℃
Storage temperature	-25℃ ~+85℃
Weight	330 g

#### Resolution

2, 4, 8, 16, 32, 64, 90, 128, 180, 250, 256, 360, 500, 512, 720, 1024

### Electrical parameters

Output circuit	PNP	PNP open collector	NPN	NPN open collector
Resolution	10 Bits	10 Bits	10 Bits	10 Bits
Supply voltage	10-30 VDC/5 VDC	10-30 VDC/5 VDC	10-30 VDC/5 VDC	10-30 VDC/5 VDC
Power consumption (no load)	≤125 mA	≤125 mA	≤80 mA	≤80 mA
Permissible load (channel)	±80 mA	±80 mA	±50 mA	±50 mA
Pulse frequency	Max300 kHz	Max300 kHz	Max. 300 kHz	Max. 300 kHz
Signal level high	Min. U <sub>b</sub> -1.5 V	Min. U <sub>b</sub> -1.5 V	Min. U <sub>b</sub> -2.5 V	MinU <sub>b</sub> *70%
Signal level low	Max. 0.4V	depends on pull-down resistor	Max. 0.4 V	Max. 0.4 V
Rise timeTr	Max. 1 μs	Max. 1 μs	Ma x.1μs	Ma x.1 μs
Fall timeTf	Max. 1 μs	Max.1 μs	Ma x.1μs	Ma x.1 μs

\*) NPN open collector is depending on the pull-up resistor. 4.7 kΩ is the recommended resistance. 8.2 kΩ is the recommended resistance for PNP open collector.

\*\*) NPN (PNP) open collector is depending on pull-up (down) resistor and cable length

# Miniature Absolute Singleturn Encoder EAC50

## Terminal Configuration

Signal	0V	+U <sub>b</sub>	bit0	bit1	bit2	bit3	bit4	bit5	bit6	bit7	bit8	bit9	V/R *
Color Code	WH	BN	GN	YE	GY	PK	BU	RD	BK	PL	GY/PK	RD/BU	YE/BN
Gray code	/	/	0	1	2	3	4	5	6	7	8	9	-

Attention  
 Bite definition of parallel interface for an absolute encoder is: bit0=MSB, bit1=MSB-1, bit2=MSB-2, .....

## Dimensions (mm)

EAC50A

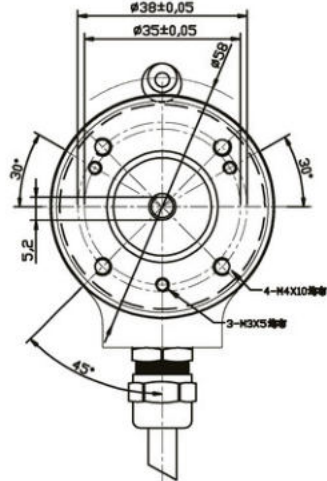
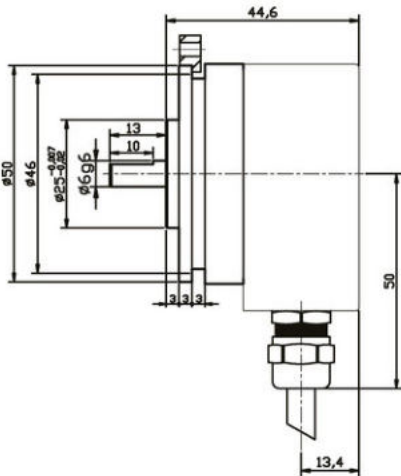

EAC50B

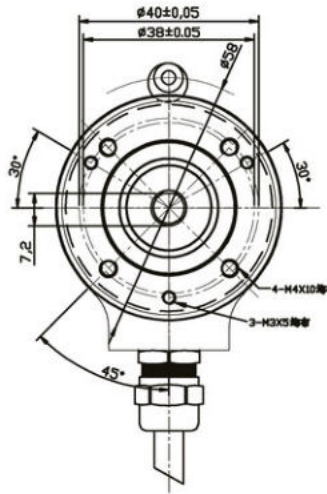
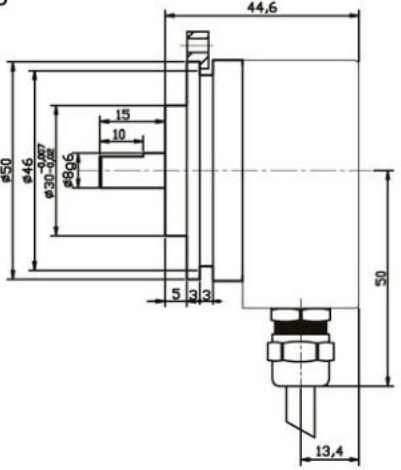

servo-restraint ring: 50PXL (see installation accessories for reference)

## Miniature Absolute Singleturn Encoder EAC50

Order Code:

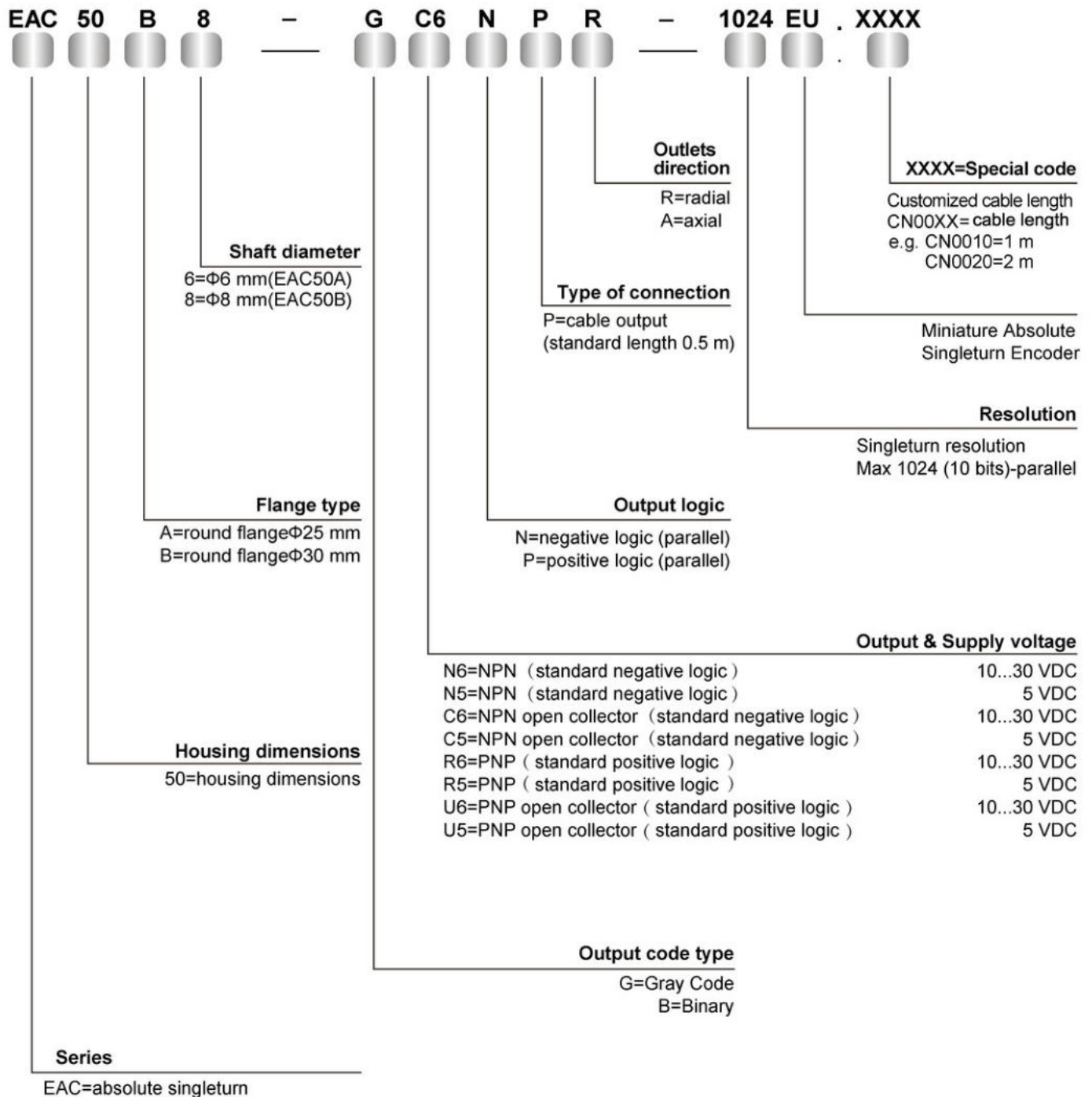

## Profibus-DP Interface Absolute Singleturn Encoder EAC58



### Description

Profibus-DP interface absolute singleturn encoder EAC58 series provides outstanding performance in withstanding mechanical damages and higher axial and radial loads. Various types of flanges are available to meet different requirements. The series complies with Profibus protocol, and its maximum resolution is up to 8192. Its high speed communication and anti-interference deliver strong and stable operation.

### Features

- Various types of flanges are available
- Pre-screwed holes are convenient for installation
- Waterproof seal provides greater IP level
- Direct cable output, which is convenient for installation and maintenance
- Protection class IP65
- Metal housing for better shock resistance
- Conforming to Profibus-DP protocol

### Mechanical parameters

Shaft diameter	Φ6g6 mm	-58B
	Φ8g6 mm	-58A/B
	Φ9.52(3/8")g6 mm	-58A
	Φ10g6 mm	-58C
Hollow shaft diameter	Φ8H7/Φ9.52H7/Φ10H7 mm	-58/W
	Φ12H7/Φ14H7/ Φ15H7 mm	-58/W
Protection class	IP65	
Speed	6000 rpm, continuous	
Axial load capacity	80 N	
Radial load capacity	160 N	
Shock resistance	50G/11 ms	
Vibration resistance	10G 10~2000 Hz	
Bearing life	10 <sup>9</sup> revolution	
Rotor moment of inertia	approx. 1.8×10 <sup>-6</sup> kgm <sup>2</sup>	
Starting torque	<0.05 Nm	
Body material	ALUNI 9002/5 -(D11S)	
Housing material	AL6060	
Flange material	ALUNI 9002/5 -(D11S)	
Operating temperature	-40...+80 °C	
Storage temperature	-45...+85 °C	
Weight	~800 g	

Resolution 8192 4096

### Electrical parameters

Resolution	8192 (13 bits)
Supply voltage	10~30 Vdc
Power consumption (no load)	300 mA
Baud rate	12 Mbaud
Linearity	+/- 1/2 LSB
Output frequency	Max 100 KHz

### Connection

+V	Supply voltage(24 VDC)
0V	Ground
A	Profibus-DPline output (GN)
B	Profibus-DPline output (RD)
A	Profibus-DPline input (GN)
B	Profibus-DPline input (RD)

## Profibus-DP Interface Absolute Singleturn Encoder EAC58

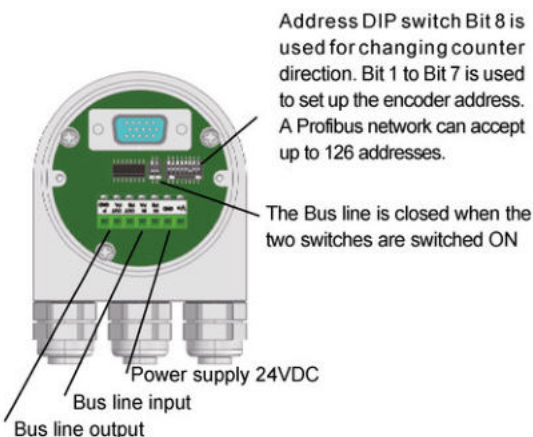
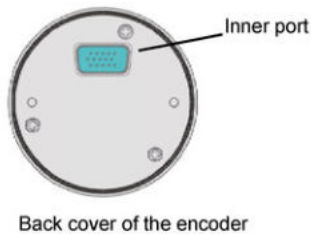
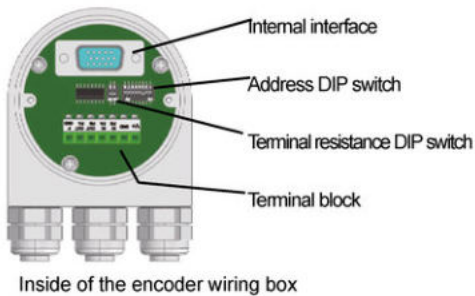
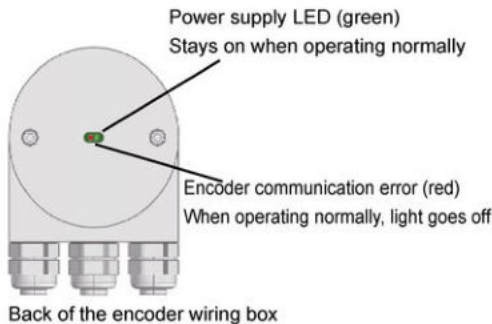

### Introduction

Profibus-DP interface absolute singleturn encoder (Identification number 0x0CCA) conforms to the Profibus-DP standard as described on the European Standard EN 50170 Vol. 2. The encoders are designed according to "Profibus Profile for Encoders, Order No. 3062".

The Profibus-DP interface has the same maximum resolution and features (8192 position/revolution) of the stand-alone version, and it also has the advantages of the Profibus-DP network. Through the Profibus-DP network is possible to:

- During the periodic data exchange, obtaining the angular position from the encoder.
- Resolution and the revolution are configurable now (please refer to the corresponding chapters for configuring the parameters).
- Changing the default increment count direction (change between CW/CCW when configuring the parameters).
- Perform the Preset operation (Set the encoder to read a specific position).
- Read the diagnosis status.
- Getting info about the code supplied by the device.

From the device it is possible to:

- Display the ON/OFF status.
- Display the device activity on the bus.
- Activate the Reset function
- Set up the device address.
- If required, insert the terminal resistance into the bus.
- Change the counting direction

### Installation

Installing the Profibus-DP encoder in a network requires the execution of the standard procedures necessary for configuring any Profibus-DP slave. The procedures are as follows:

- 1- Add the slave onto the master (please see corresponding chapter).
- 2- Wire the encoder into the Profibus network. Whether wiring it in the middle or at the terminal are depending on the physical position the device has in the bus.
- 3- Directly set up the address (which must be unique in the network and as the same as the device) for the slave.
- 4- Prepare the applications at the master side and set up the Profibus network.

On the back cover of the encoder there are two LED indicators. The device's operating status can be observed by the two LEDs. The green LED shows the power status and must be on constantly. The red LED only switches off during the periodic data exchange between the Profibus master and the encoder.

Note: To set and configure the slave into the Profibus-DP master, it is necessary to use the "gsd" file delivered with the encoder. The file can be found on the CD.

### DIP-switch setup (configuring slave address)

Besides the address and the standard position of a terminal DIP switch, a configuration example of Profibus and the devices is illustrated below.

In this example, device's address is set up as 1001101, with the corresponding decimal address as 77. Bit 7 is the top digit, and bit 1 is the lowest digit. Bit 8 is used for changing the counter direction. Bit 1 to bit 7 are used to configuring encoder's address.

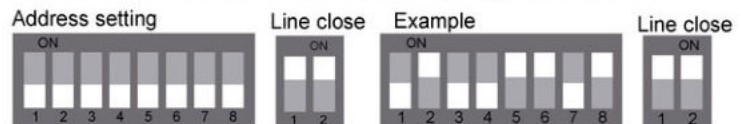

### Network Characteristics

Usually, an A type cable is used to wire a DP/FMS network. This cable has to have the following characteristics:

Parameter	A type cable
Characteristic resistance ( $\Omega$ )	135...165 at a certain frequency (3...20Mhz)
Rated capacity (PF/m)	<30
Loop resistance ( $\Omega$ /Km)	<=110
Core diameter (mm)	>0.64*
Core cross-section (mm <sup>2</sup> )	>0.34*

This cable allows the optimal network utilization. In fact, it is possible to reach the maximum communication speed allowed (12Mbaud). However, there are some limitations due to the maximum physical dimensions of a bus segment as follows:

kbauD	9.6	19.2	93.75	187.5	500	1500	12000
Range/Segment	1200 m	1200 m	1200 m	1000 m	400 m	200 m	100 m

Finally, the physical characteristics of a Profibus network are learned.

## Profibus-DP Interface Absolute Singleturn Encoder EAC58

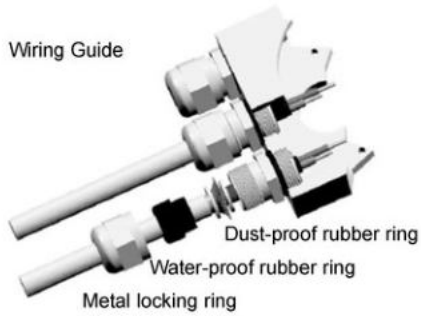

Max. number of station participating in the exchange of user data	DP: 126 (Address 0-125) FMS: 127 (Address 0-126)
Max. number of stations per segment	32
Available data transfer rates (kbit/s)	9.6, 19.2, 45.45, 93.75, 187.5, 500, 1500, 3000,
Max. segments	6000, 12000

According to EN50170, a maximum of 4 repeaters are allowed between any two stations. Dependent on the repeater type and manufacturer, more than 4 repeaters may be allowed in some cases. Refer to the manufacturer's technical specification for details.

### Wiring box

Unscrew the back cover, and wire the cables (power cable, input and output bus) according to the instructions on the cover. The cable will pass through the metallocking ring, water-proof rubber ring, and dust-proof rubber ring into the metal notch. Lock the metal ring to fasten the cables

### Dimensions (mm)

#### EAC58A

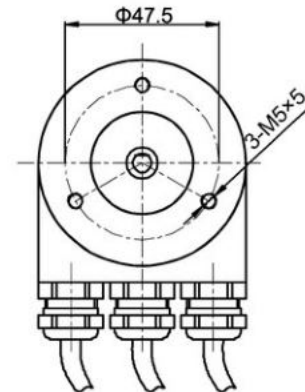
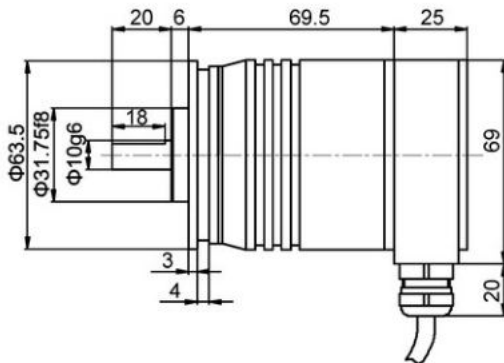

#### EAC58B

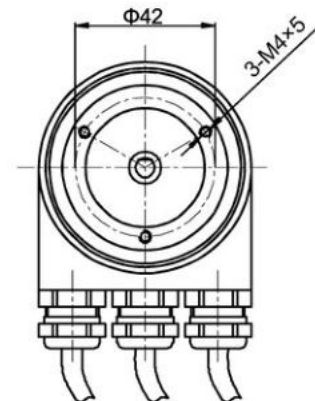
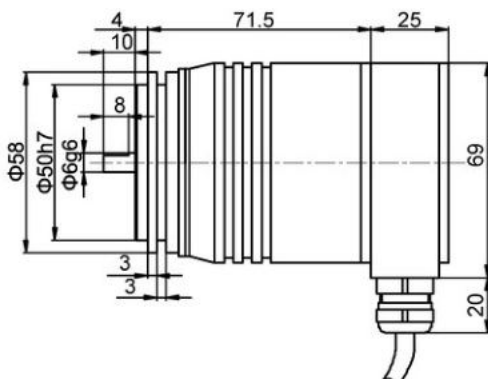

Profibus-DP Interface Absolute Singleturn Encoder EAC58

Dimensions (mm)

EAC58C

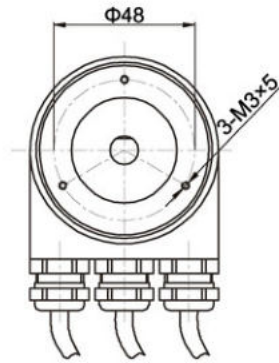
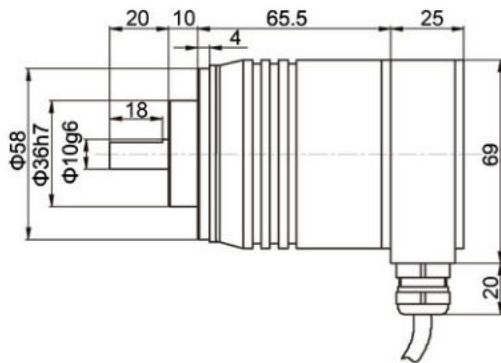

EAC58W

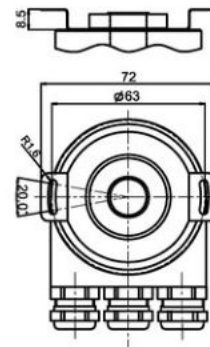
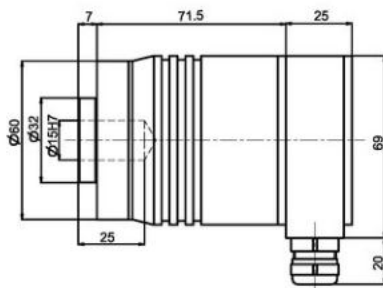

# Profibus-DP Interface Absolute Singleturn Encoder EAC58

Order Code:

**EAC 58 C 10 - B F6 X X R - 8192 DP**

Profibus-DP Interface  
Absolute Encoder

**Resolution**

resolution (see previous pages for reference)  
standard 8192 (13 bits)

**Outlets direction**

R=radial

**Type of connection**

X=integrated coupler terminal box with 3 PG7 threaded connectors  
T=integrated coupler terminal box with 3 M12 plugs

**Output logic**

X= No definition

**Output & Supply voltage**

F6=Profibus-DP interface 10...30 Vdc

**Code type**

B=Binary

**Flange type**

A=round flange  
B=synchro flange, shaft length 10 mm  
C= $\Phi$ 36 clamping flange, shaft length 20 mm  
W=blind hollow shaft flange, double-winged spring leaf installation

**Housing diameter**

58= $\Phi$ 58 flange

**Series**

EAC=Profibus-DP interface absolute singleturn

**Shaft/ Hollow shaft diameter**

6= $\Phi$ 6g6 mm (58B)  
8= $\Phi$ 8g6 mm 58A/B  
9= $\Phi$ 9.52g6 mm 58A  
10= $\Phi$ 10g6 mm  
Only for flange type 58W  
8 = $\Phi$ 8H7 mm  
9 = $\Phi$ 9.52H7 mm  
10= $\Phi$ 10H7 mm  
12= $\Phi$ 12H7 mm  
14= $\Phi$ 14H7 mm  
15= $\Phi$ 15H7 mm

## 4...20mA Analog Output Absolute Singleturn Encoder EAC58



### Description:

The 4-20mA Analog output absolute singleturn encoder EAC58 series features a compact structure with strong performance in withstanding mechanical damages and higher axial and radial loads. EAC58 series is equipped with the RESET function, and has the resolution up to 8192. 4-20mA output is compatible with special PC controllers.

### Features:

- Waterproof seal provides greater IP level
- Pre-screwed holes for convenience purpose
- Durable stainless steel shaft
- Metal housing for better shock resistance
- Protection class IP65
- Staring and finishing points calibration function equipped

### Mechanical parameters

Shaft diameter	Φ6g6/Φ10h8 mm
Protection class	IP65
Speed	6000 r/m
Max load capacity of the shaft	
Axial load capacity	60 N
Radial load capacity	120 N
Shock resistance	50G/11 ms
Vibration resistance	10G 10~2000 Hz
Bearing life	10 <sup>9</sup> revolution
Rotor moment of inertia	1.8×10 <sup>-6</sup> kgm <sup>2</sup>
Starting torque	<0.01 Nm
Body material	AL-alloy
Housing material	AL-alloy
Operating temperature	-20...+80 °C
Storage temperature	-25...+85 °C
Weight	360 g

Resolution: 8192. For other resolution requests please contact us for further information.

### Electrical parameters

Type of Interface	4...20 mA	0...10 V
Supply voltage (U <sub>b</sub> )	10...30 VDC/5 VDC	10...30 VDC
Current consumption	70 mA	70 mA
Max.loading current	84 mA	84 mA
Word-updating frequency	Max. 15.000/s	Max. 15.000/s
Current loop	10...30 VDC	10...30 VDC
Analog signal	4...20 mA	0...10 V
Max.input resistance	200 Ω	200 Ω
Measuring range	0...360°	0...360°
Max.sensitivity (25 °C)	0.2°	0.2°
Resolution	13 Bit	13 Bit
Setup time	Max. 2 ms	Max. 2 ms
Temperature effect	0.1° /10 K	0.1° /10 K
No-load current	≤3.5 mA	≤3.5 mA
Sensor should be electrically isolated form current loop		

Conforms to CE requirements of EN 61000-6-1, EN 61000-6-4 and EN 61000-6-3

## 4...20mA Analog Output Absolute Singleturn Encoder EAC58

### Terminal Configuration

Voltage signal	0V	+U <sub>b</sub>	VOUT+	VOUT-	VIN+	VIN-	STZ	VR	STT	----	----	----	⊥
Current Signal	0V	+U <sub>b</sub>	----	----	+I	-I	STZ	VR	STT	----	----	----	⊥
Color	WH	BN	GN	YE	GY	PK	BU	RD	BK	VT	GY/PK	RD/BU	
Gray	1	2	3	4	5	6	7	8	9	10	11	12	PH

Top view of the connecting end on needle connector block

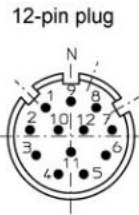

12-pin plug

- +I: Input of current loop      0V/+U<sub>b</sub> and VIN+/VIN-: can be powered together or separately
  - I: Output of current loop      VOUT+/VOUT-: voltage output      VIN-/VOUT-: connected in circuit
  - STZ: SET input (signal level remains high for 2 sec), the output current is set to 4 mA
  - VR: Up/down input, as the input is activated, decreasing current values are transmitted when shaft turning clockwise
  - STT input: SET input (signal level remains high for 2 sec), the output current is set to 20 mA
  - PH: Plug housing
- Attention: 1, Before initial start-up, unused outputs must be insulated.  
 2, Shaft remains static, and at the same time set STZ & STT signal at high level; singleturn resumes to 4-20mA, and the present position output is at 4 mA.

### Dimensions (mm)

EAC58B

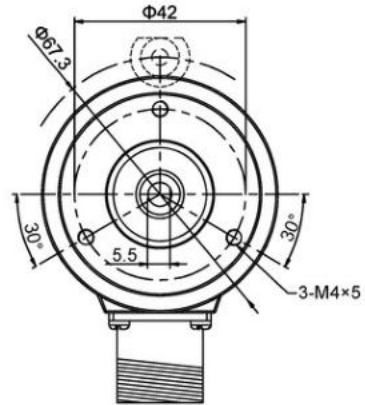
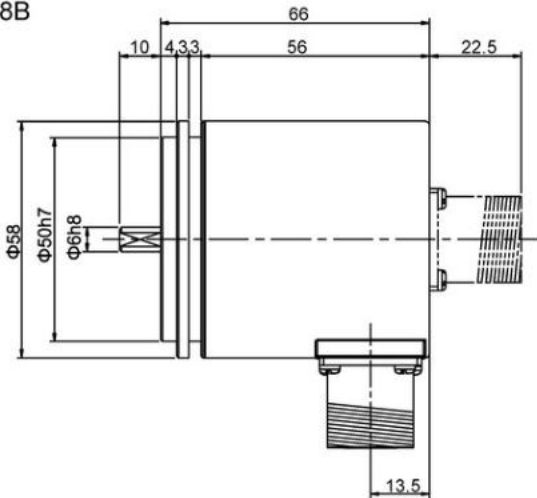

EAC58C

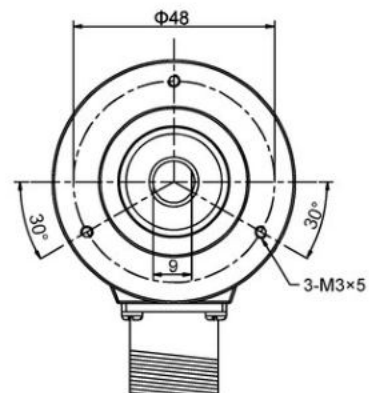
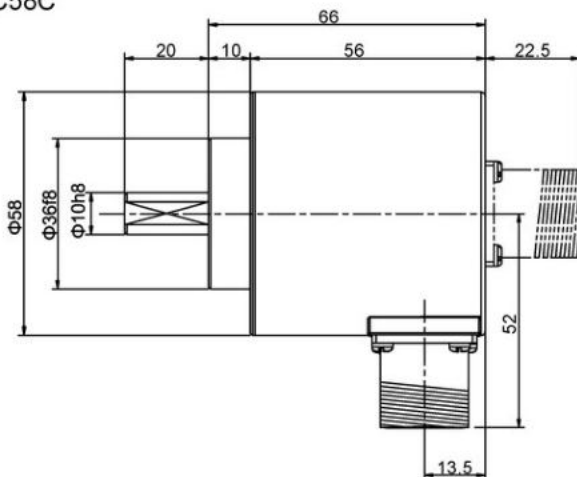

## 4...20mA Analog Output Absolute Singleturn Encoder EAC58

Order Code

**EAC 58 C 10 - G S6 X PC R - 8192 EA . XXXX**

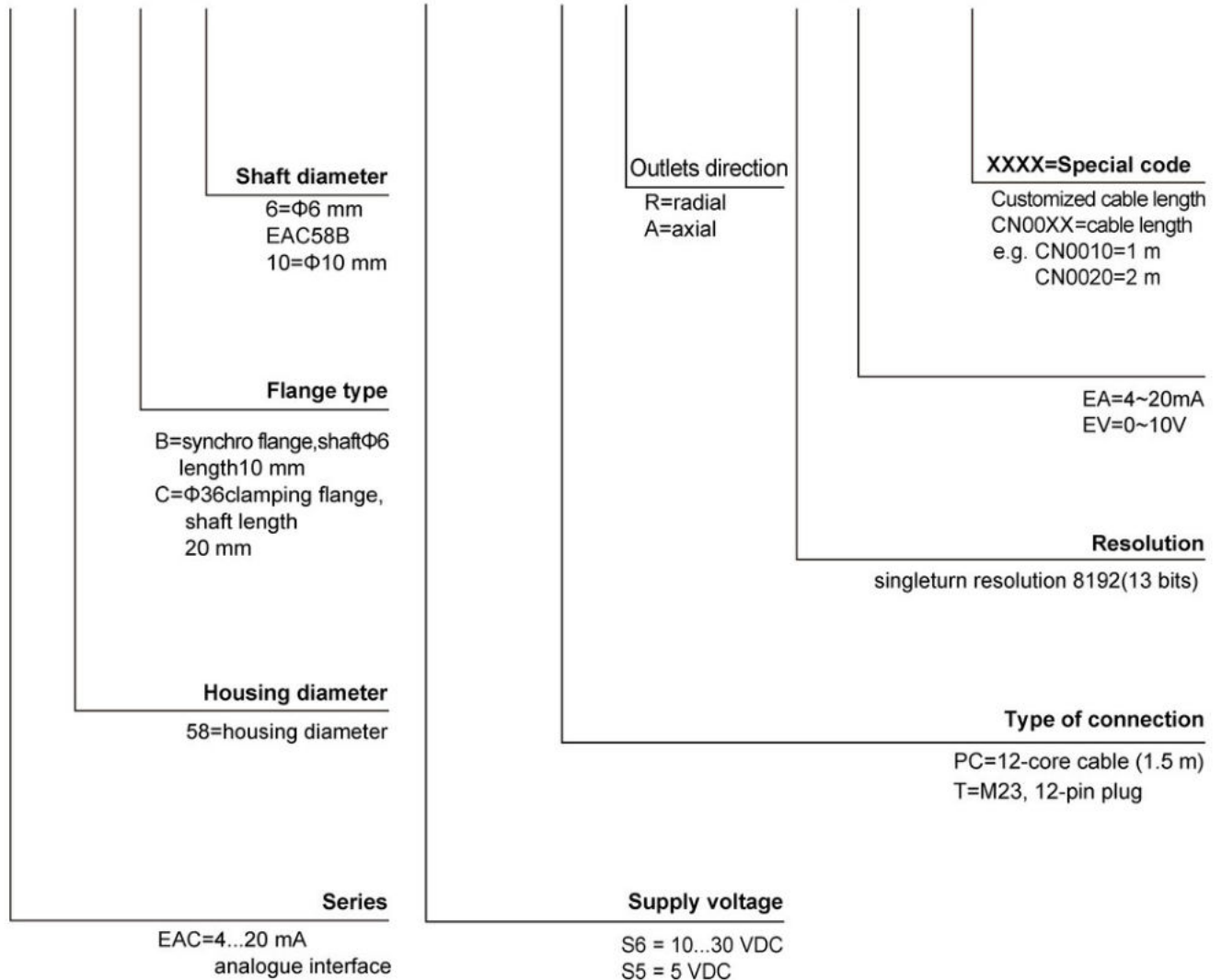

## Standard Absolute Singleturn Encoder EAC58



### Description

Standard absolute singleturn encoder EAC58 series can be widely used in various industrial environments. The series also has a good performance against mechanical damage and can withstand higher axial and radial load. Various flange types and connections are available. EAC58 series also has the RESET function and resolution up to 8192.

### Features

- Pre-screwed holes for easy installation
- Waterproof seal provides greater IP level
- Durable stainless steel shaft
- Metal housing for shock resistance
- Protection class IP65
- Reverse connection protection and short circuit protection

### Mechanical parameters

Shaft diameter	Φ6/Φ8/Φ9/Φ10h8 mm
Protection class	IP65
Speed	6000 r/m
Max load capacity of the shaft	
Axial load capacity	60 N
Radial load capacity	120 N
Shock resistance	50G/11 ms
Vibration resistance	10G 10~2000 Hz
Bearing life	10 <sup>9</sup> revolution
Rotor moment of inertia	1.8×10 <sup>-6</sup> kgm <sup>2</sup>
Starting torque	<0.01 Nm
Body material	AL-alloy
Housing material	AL-alloy
Operating temperature	-20...+80 ℃
Storage temperature	-25...+85 ℃
Weight	360 g

Resolution

SSI: 1024, 2048, 4096, 8192

Parallel: 2, 4, 8, 16, 32, 64, 128, 256, 512, 1024, 2048, 4096, 8192

### Electrical parameters

Output circuit	SSI	SSI	Parallel	Parallel
Output driver	RS422	RS422	Push-pull/NPN open collector	
Resolution	13 Bits	13 Bits	13 Bits	13 Bits
Supply voltage	10...30 VDC	5 VDC	10...30 VDC	5 VDC
Power consumption (no load)	≤200 mA	≤200 mA	≤200 mA	≤200 mA
Permissible load (channel)	±20 mA	±20 mA	±20 mA	±20 mA
Pulse frequency	Max. 1 MHz	Max. 1 MHz	Max. 40 kHz	Max. 40 kHz
Signal level high	Typ. 3.8 V	Typ. 3.8 V	MinUb-2.8 V	Min. 3.4 V
Signal level low	Max. 0.5 V	Max. 0.5 V	Max. 2.0 V	Max. 0.5 V
Rise time Tr	Max. 100 ns	Max. 100 ns	Max. 0.2 μs	Max. 0.2 μs
Fall time Tf	Max. 100 ns	Max. 100 ns	Max. 0.2 μs	Max. 0.2 μs

## Standard Absolute Singleturn Encoder EAC58

### Terminal Configuration

#### SSI Wiring Guide

Signal	0V	+U <sub>b</sub>	+C	-C	+D	-D	ST*	V/R*	Shielded
Color Code	WH	BN	GN	YE	GY	PK	BU	RD	⊥
12-pin	1	2	3	4	5	6	7	8	PH

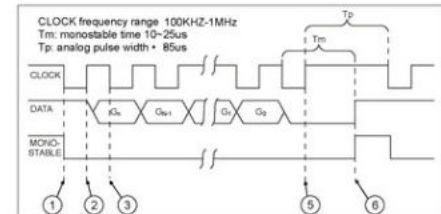

#### Parallel Wiring Guide

Signal	0V	+U <sub>b</sub>	bit0	bit1	bit2	bit3	bit4	bit5	bit6	bit7	bit8	bit9	bit10	bit11	bit12	V/R*	ST*
Color	WH	BN	GN	YE	GY	PK	BU	RD	BK	PL	GY/PK	RD/BU	WH/GN	BN/GN	WH/YE	YE/BN	WH/GY
17-pin	1	2	3	4	5	6	7	8	9	10	11	12	13	14	15	16	17
Gray	/	/	1	2	3	4	5	6	7	8	9	10	11	12	13	/	/
Binary																	

#### Attention

Bit definition of parallel interface for an absolute encoder is: bit0=MSB, bit1=MSB-1, bit2=MSB-2,.....

### Dimensions (mm)

#### EAC58A

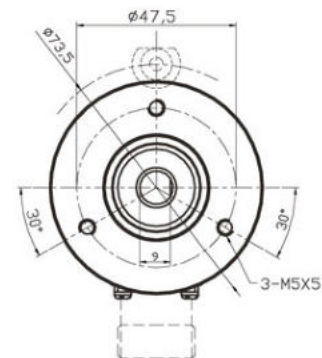
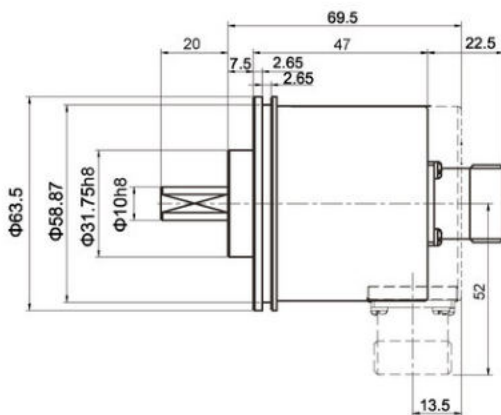

servo-restraint ring:

58PXL (see installation accessories for reference)

#### EAC58B

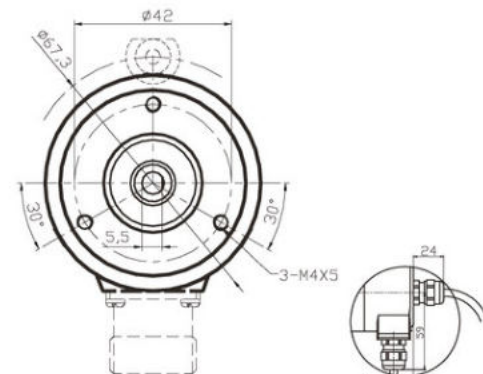
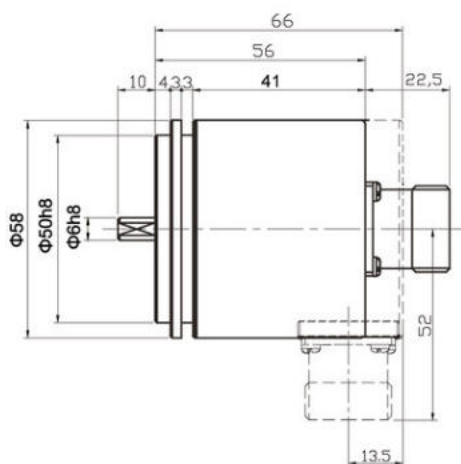

Rmin

fasten mount: 55mm

Hauling mount: 70mm cable output

# Standard Absolute Singleturn Encoder EAC58

## Dimensions (mm)

EAC58C

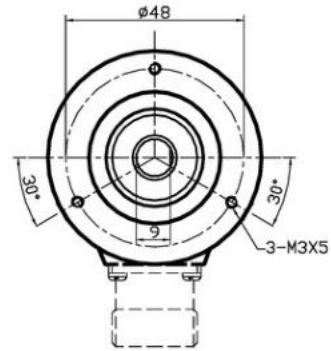
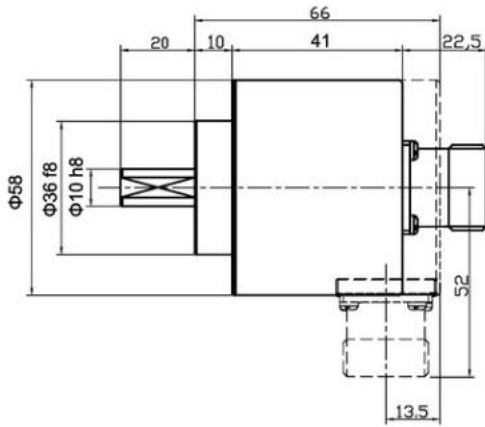

EAC58D

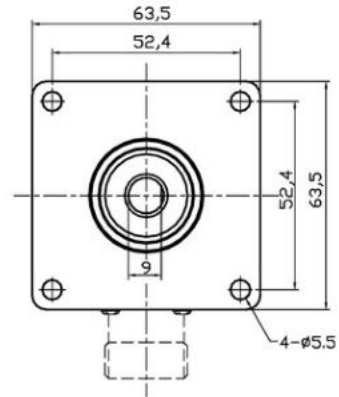
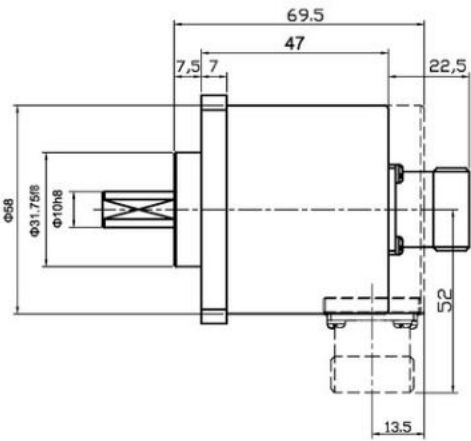

Note: Do not use excessive force during hardwiring between driving shaft, flange and encoder to prevent shaft damage from overload.

Top view of 12-pin encoder

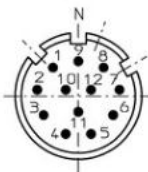

Top view of 17-pin encoder

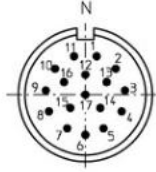

Hole arrangement for of 17-pin connector



Size

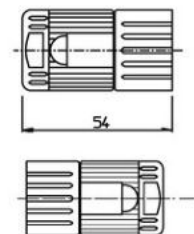

## Standard Absolute Singleturn Encoder EAC58

Order Code:

**EAC 58 C 10 - G S6 X PC R - 8192 EU . XXXX**

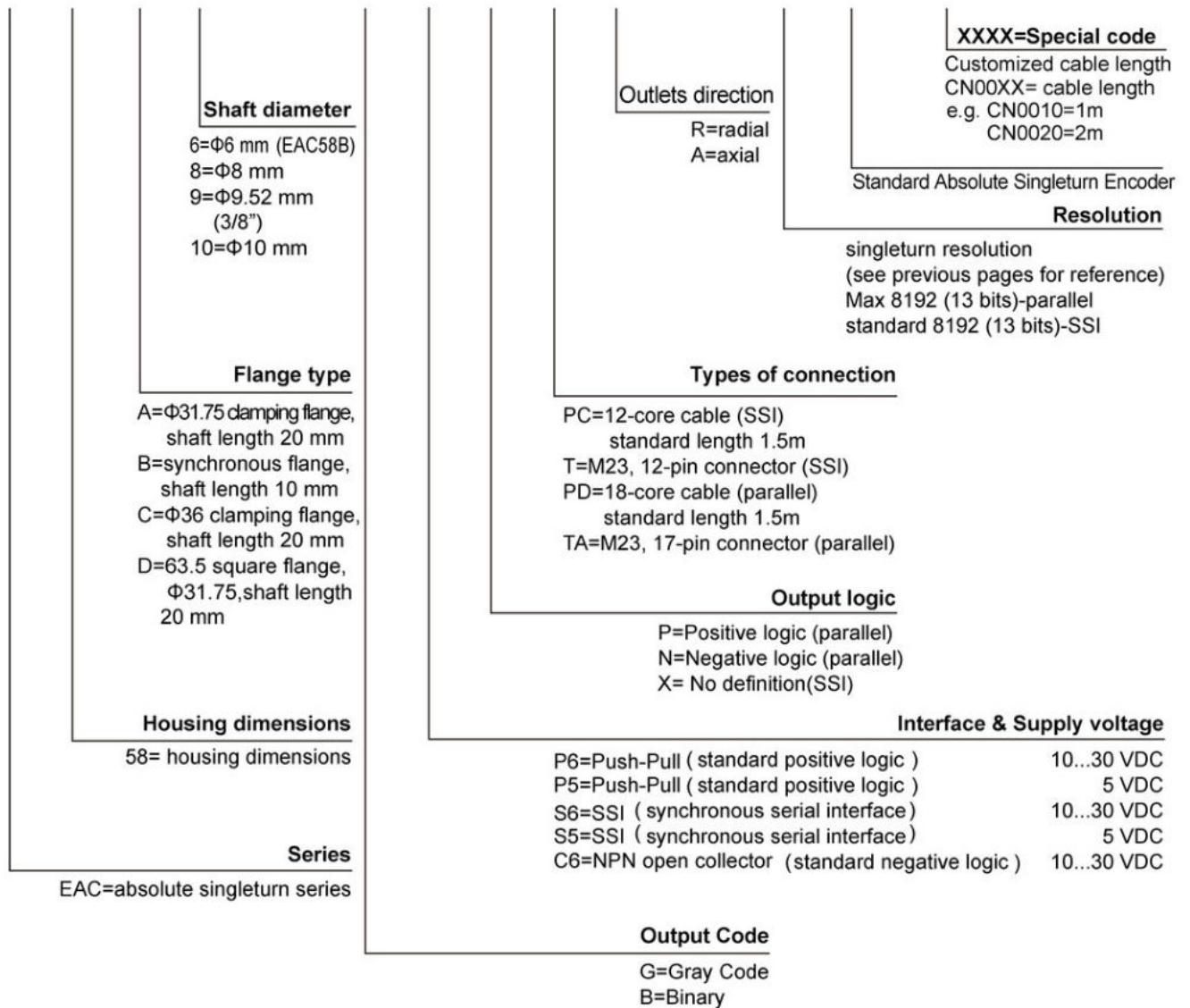

Connector accessories  
 Connectors matching with "T" wiring  
 Ordering code: TMSP1612F  
 Connectors matching with "TA" wiring  
 Ordering code: TMSP1617F

This sample is for reference only, please subject to the actual products.  
 Please contact ELCO for further specification requests and requirements.

## Standard Hollow Shaft Absolute Singleturn Encoder EAC58P



### Description

Standard absolute singleturn encoder EAC58P series can be widely used in various industrial environments. The series also has a good performance against mechanical damage, and withstanding higher axial and radial load. Various flange types and connections are available. EAC58P series is also equipped with the RESET function with resolution up to 8192.

### Features

- Hollow shaft installation saves space with "C" ring lock
- $\Phi 8/10/12$  hollow shaft for easy applications
- Waterproof seal provides greater IP level
- Metal housing is capable of withstanding higher axial and radial loads
- Protection class IP65
- Output cables or connectors are available for easy maintenance

### Mechanical Characteristics

Hollow shaft diameter	$\Phi 8/\Phi 10/\Phi 12H7$ mm
Protection class	IP65
Speed	6000 r/m
Max load capacity of the shaft	
Axial load capacity	60 N
Radial load capacity	1200 N
Shock resistance	50G/11 ms
Vibration resistance	10G 10~2000 Hz
Bearing life	$10^9$ revolution
Rotor moment of inertia	$1.8 \times 10^{-6}$ kgm <sup>2</sup>
Starting torque	<0.01 Nm
Body material	AL-alloy
Housing material	AL-alloy
Operating temperature	-20...+80 °C
Storage temperature	-25...+85 °C
Weight	360 g

#### Resolution

SSI: 1024, 2048, 4096, 8192

Parallel: 2, 4, 8, 16, 32, 64, 128, 256, 512, 1024, 2048, 4096, 8192

### Electrical Characteristics

Output circuit	SSI	SSI	Parallel	Parallel
Output driver	RS422	RS422	Push-pull/NPN OC	
Resolution	13 Bits	13 Bits	13 Bits	13 Bits
Supply voltage	10...30 VDC	5 VDC	10...30 VDC	5 VDC
Power consumption (no load)	$\leq 200$ mA	$\leq 200$ mA	$\leq 200$ mA	$\leq 200$ mA
Permissible load (channel)	$\pm 20$ mA	$\pm 20$ mA	$\pm 20$ mA	$\pm 20$ mA
Pulse frequency	Max. 1 MHz	Max. 1 MHz	Max. 40 kHz	Max. 40 kHz
Signal level high	Typ. 3.8 V	Typ. 3.8 V	Typ. Ub-2.8 V	Typ. 3.4 V
Signal level low	Max. 0.5 V	Max. 0.5 V	Max. 2.0 V	Max. 0.5 V
Rise timeTr	Max. 100 ns	Max. 100ns	Max. 0.2 $\mu$ s	Max. 0.2 $\mu$ s
Fall timeTf	Max. 100 ns	Max. 100ns	Max. 0.2 $\mu$ s	Max. 0.2 $\mu$ s

## Standard Hollow Shaft Absolute Singleturn Encoder EAC58P

### Terminal Configuration

#### SSI Wiring Guide

Signal	0V	+U <sub>b</sub>	+C	-C	+D	-D	ST*	V/R*	Shield
Color	WH	BN	GN	YE	GY	PK	BU	RD	⊥
12-pin	1	2	3	4	5	6	7	8	PH

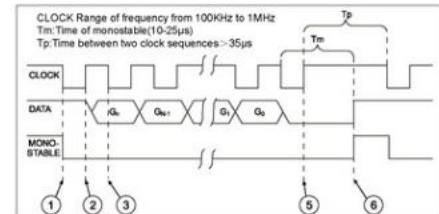

#### Parallel

Signal	0V	+U <sub>b</sub>	bit0	bit1	bit2	bit3	bit4	bit5	bit6	bit7	bit8	bit9	bit10	bit11	bit12	V/R*	ST*
Color	WH	BN	GN	YE	GY	PK	BU	RD	BK	VT	GY/PK	RD/BU	WH/GN	BN/GN	WH/YE	YE/BN	WH/GY
12-pin	1	2	3	4	5	6	7	8	9	10	11	12	13	14	15	16	17
Gray	/	/	1	2	3	4	5	6	7	8	9	10	11	12	13	/	/
Binary																	

#### Attention

Bit definition of parallel interface for an absolute encoder is: bit0=MSB, bit1 =MSB-1, bit2=MSB-2,

### Dimensions (mm)

#### EAC58P(Q)

P without installation accessories

Q short torque support slot

Accessories:

E23230010A/0

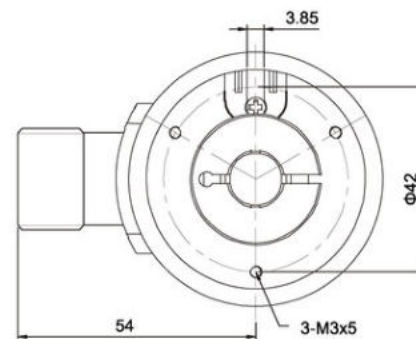
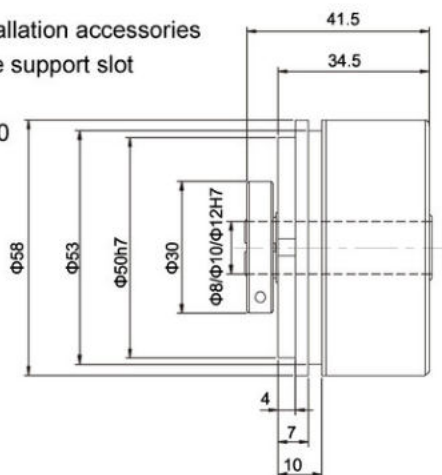

#### EAC58H

Accessories:

E41350050A/0

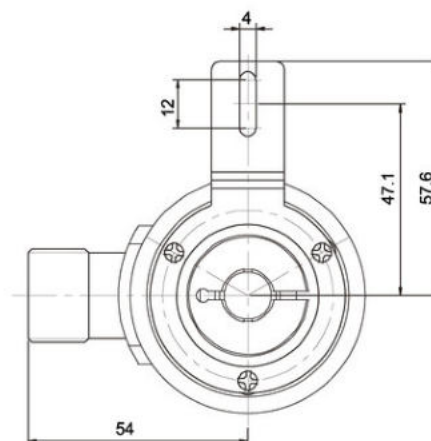
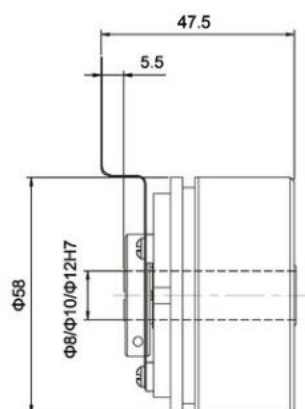

## Standard Hollow Shaft Absolute Singleturn Encoder EAC58P

### Dimensions (mm)

EAC58K  
Accessories:  
E41220001A/0  
E4700 0000

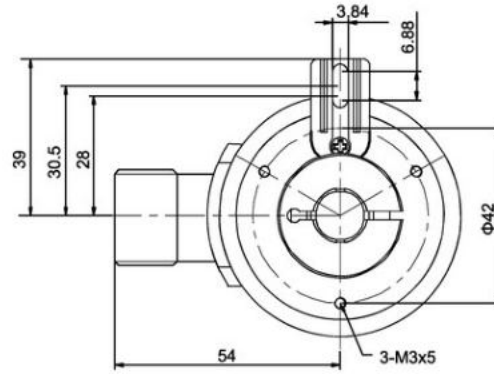
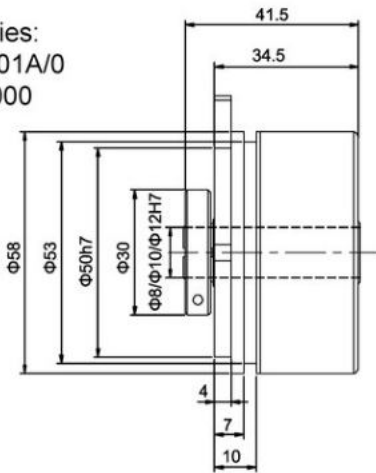

EAC58W  
Accessories:  
E41350042A/1

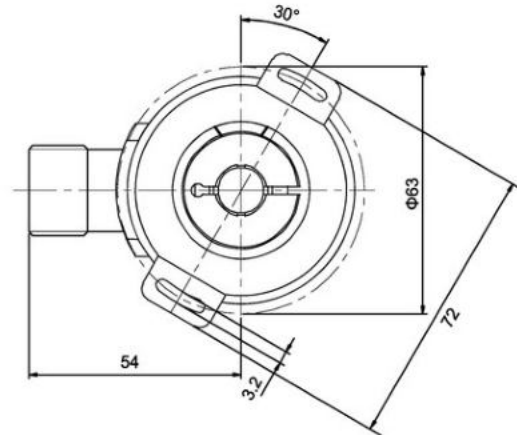
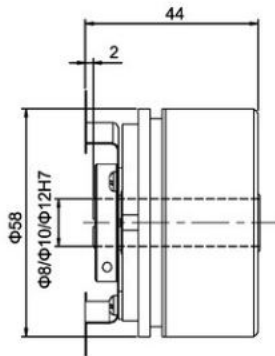

## Standard Hollow Shaft Absolute Singleturn Encoder EAC58P

Order Code:

**EAC 58 W 10 - G S6 X PC R - 8192 EU . XXXX**

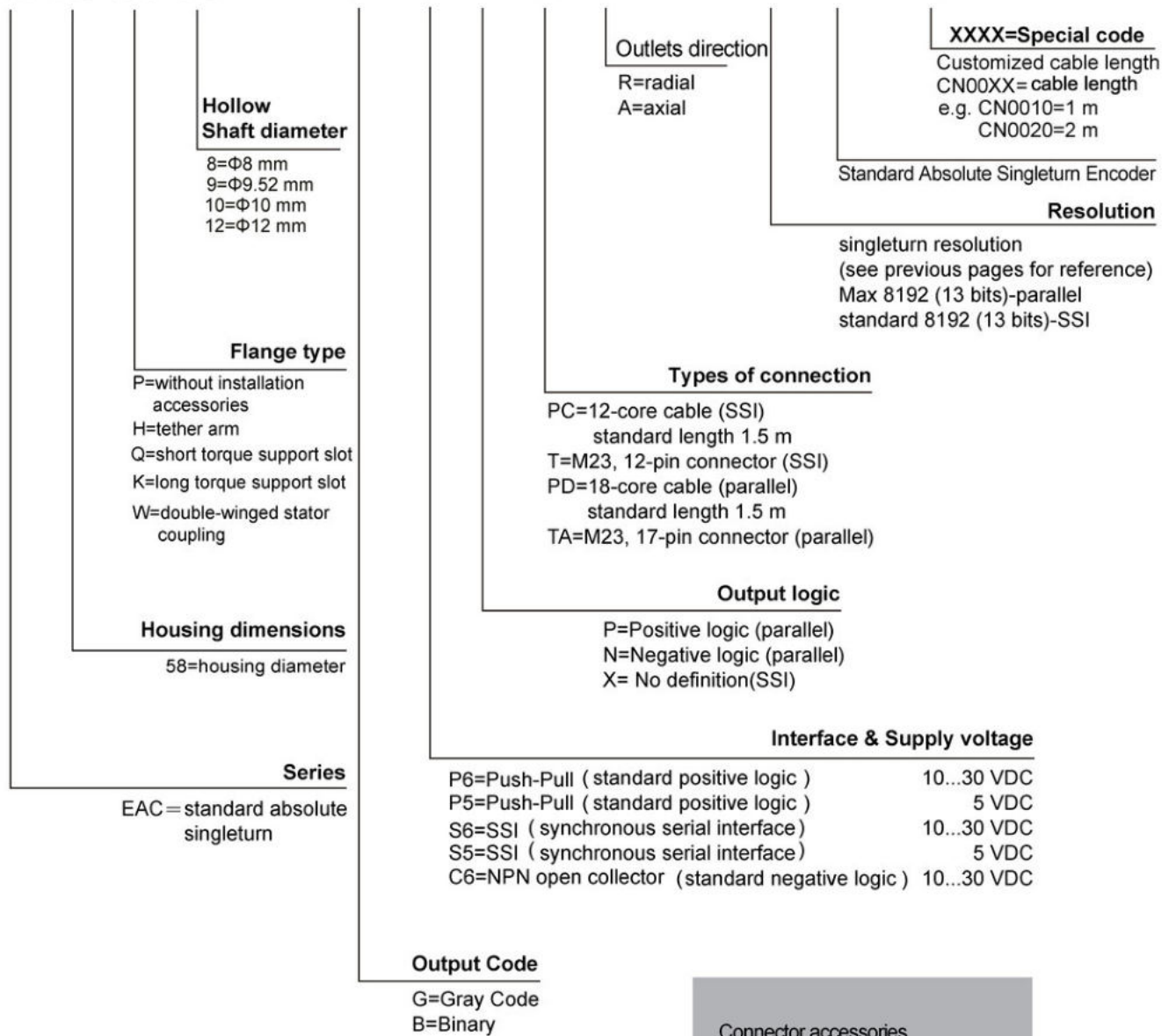

Connector accessories  
 Connectors matching with "T" wiring  
 Ordering code : TMSP1612F  
 Connectors matching with "TA" wiring  
 Ordering code : TMSP1617F

This sample is for reference only, please subject to the actual product.  
 Please contact ELCO for further specification requests and requirements.

## 4...20mA Analog Output Absolute Multiturn Encoder EAM58



### Description:

4...20mA Analog output absolute multiturn encoder EAM58 series, designed with compact structure is capable to withstand higher axial and radial loads. European standard flanges provide great convenience in installation. The encoder can provide 16 bits and 4...20mA analog and data outputs to meet the specific interface needs of PC. Multiple configurations of resolution and number of turns are available to meet different application requirements.

### Features:

- European standard flange
- Waterproof seal provides greater IP level
- Pre-screwed holes for convenience purpose
- Durable stainless steel shaft
- Metal housing for better shock resistance
- Protection class IP65
- Output cables or connectors are available for easy installation and maintenance
- 4...20mA Analog output

### Mechanical parameters

Shaft diameter	Φ6g6/Φ8g6/Φ10g6 mm
Hollow shaft diameter	Φ8H7/Φ10H7/Φ12H7/Φ15H7 mm
Protection class	IP65
Speed	6000 r/m
Max load capacity of the shaft	
Axial load capacity	80 N
Radial load capacity	160 N
Shock resistance	50G/11 ms
Vibration resistance	10G 10~2000 Hz
Bearing life	10 <sup>9</sup> revolution
Rotor moment of inertia	1.8×10 <sup>-6</sup> kgm <sup>2</sup>
Starting torque	<0.01 Nm
Body material	AL-alloy
Housing material	Zn AL-alloy
Operating temperature	-40...+80 °C
Storage temperature	-45...+85 °C
Weight	360...750 g

### Electrical parameters

Output circuit	4...20 mA	0...10 V
Supply voltage(U <sub>b</sub> )	10...30 VDC/5 VDC	10...30 VDC
Power consumption typ.	70 mA	70 mA
No load Max.	84 mA	84 mA
Word change frequency	Max 15.000/s	Max. 15.000/s
Current loop supply voltage	10...30 VDC	10...30 VDC
Analogue signal	4... 20 mA	0...10 V
Max. input resistance	200 Ω	200 Ω
Measuring range	Based on actual resolution	Based on actual resolution
Max. sensitivity (25 $\times$ )	0.2°	0.2°
Resolution	16 Bit	16 Bit
Building up time	Max. 2 ms	Max. 2 ms
Temperature coefficient	0.1° /10 K	0.1° /10 K
Power consumption (no load)	≤3.5 mA	≤3.5 mA
Sensors must be electrically insulated from current loop.		

Conforms to CE requirements: EN 61000-6-1, EN 61000-6-4 and EN 61000-6-3

## 4...20mA Analog Output Absolute Multiturn Encoder EAM58

### Terminal Configuration

Voltage signal	0V	+U <sub>b</sub>	VOUT+	VOUT-	VIN+	VIN-	STZ	VR	STT	—	—	—	⊥
Current Signal	0V	+U <sub>b</sub>	—	—	+I	-I	STZ	VR	STT	—	—	—	⊥
Color	WH	BN	GN	YE	GY	PK	BU	RD	BK	VT	GY/PK	RD/BU	
Gray	1	2	3	4	5	6	7	8	9	10	11	12	PH

Top view of the connecting end on needle connector block 12-pin plug

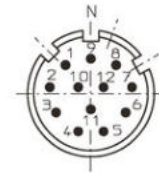

**+I:** Input of current loop

**0V/+U<sub>b</sub>** and **VIN+/VIN-**: can be powered together or separately

**-I:** Output of current loop

**VOUT+/VOUT-**: voltage output

**VIN-/VOUT-**: connected in circuit

**STZ:** SET input (signal level remains high for 2 sec), the output current is set to 4 mA

**VR:** Up/down input, as the input is activated, decreasing current values are transmitted when shaft turning clockwise

**STT input:** SET input (signal level remains high for 2 sec), the output current is set to 20 mA

**PH:** Plug housing

Attention: 1. Before initial start-up, unused outputs must be insulated..

2. Shaft remains static, and at the same time set STZ & STT signal at high level; singleturn resumes to 4...20 mA, and the present position output is at 4 mA.

### Dimensions (mm)

EAM58B

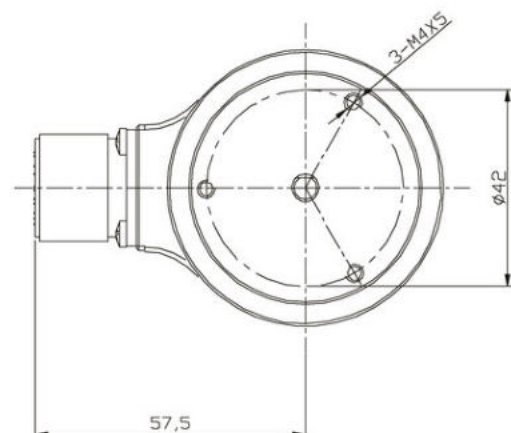
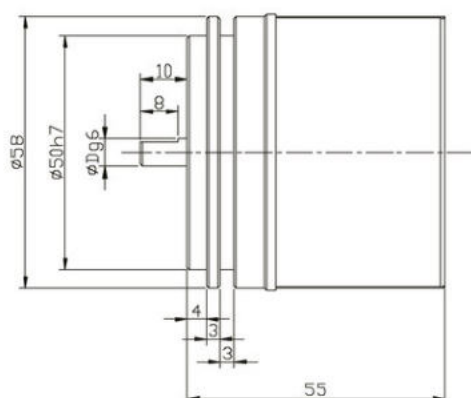

## 4...20mA Analog Output Absolute Multiturn Encoder EAM58

### Dimensions (mm)

EAM58C

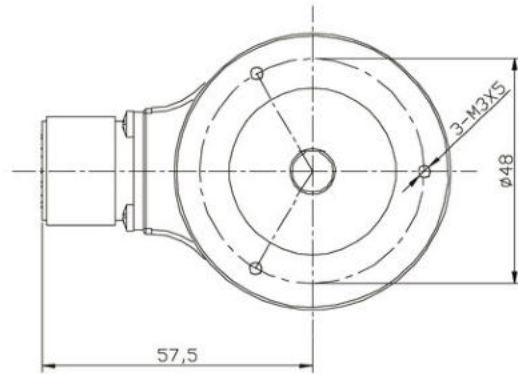
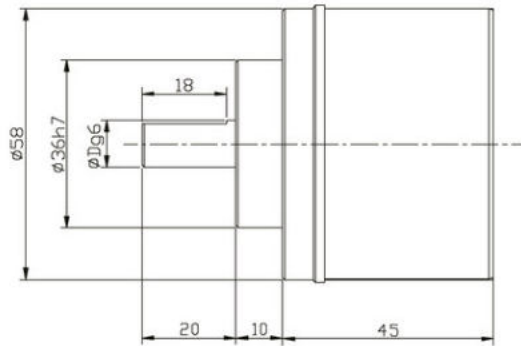

EAM58W

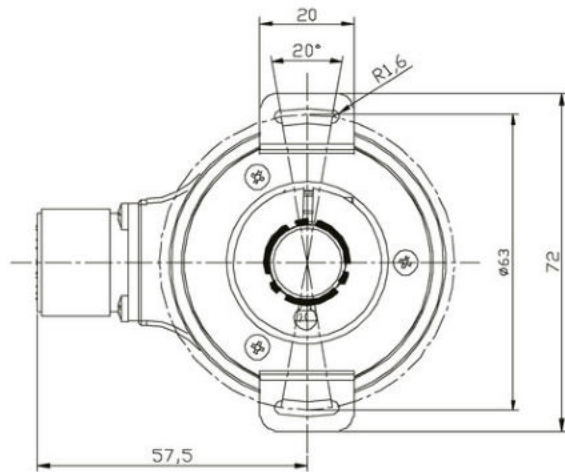
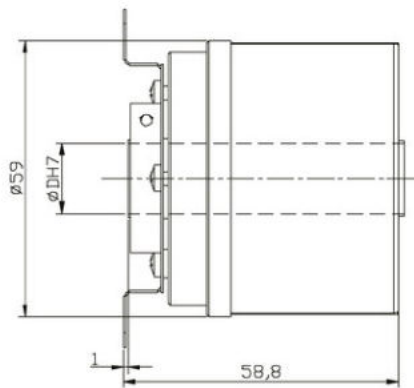

## 4...20mA Analog Output Absolute Multiturn Encoder EAM58

### Order Code

**EAM 58 C 10 - G S6 X PC R - 16/4096 EAND . XXXX**

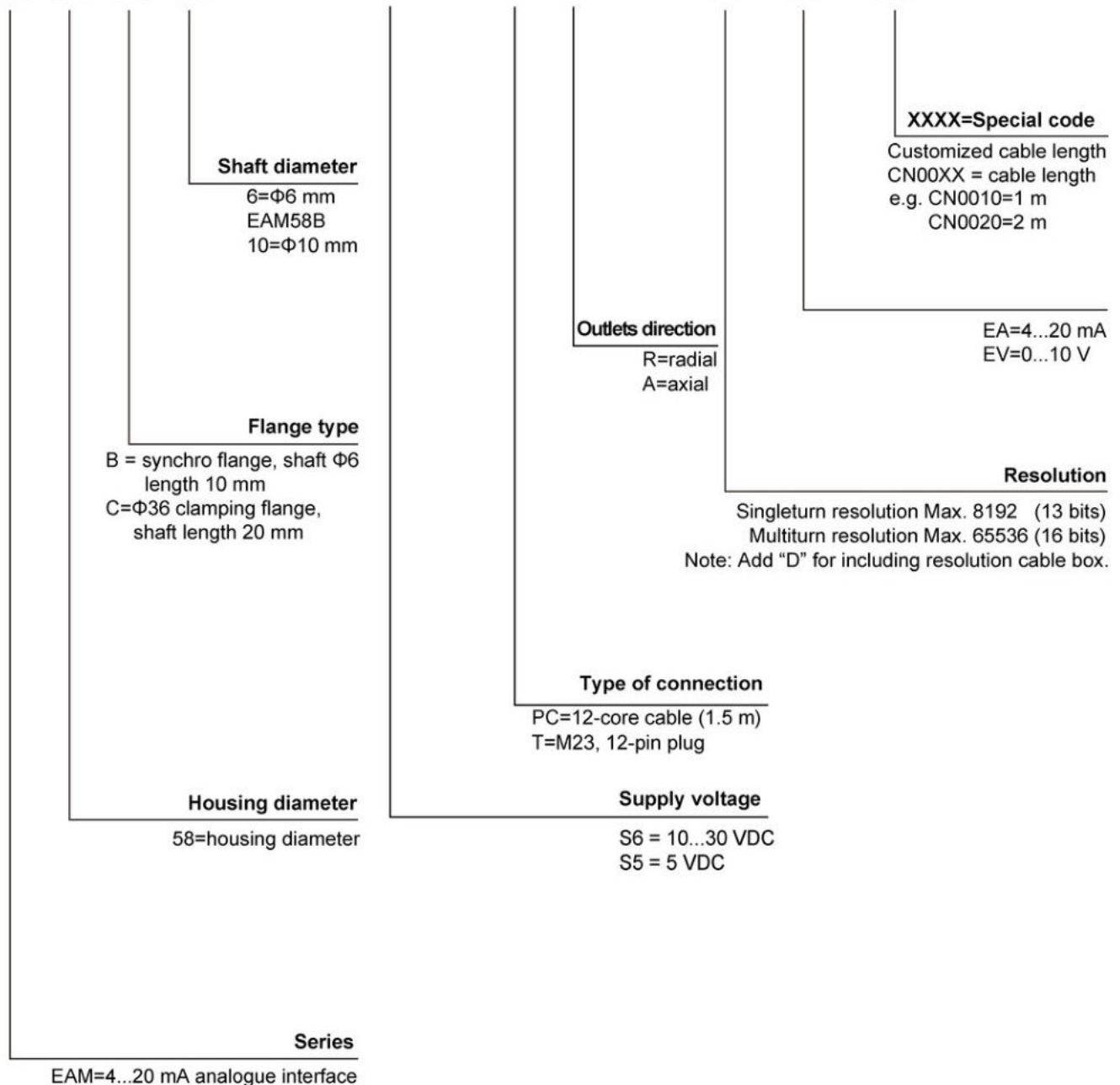

## Standard Absolute Multiturn Encoder EAM58



### Description:

Standard absolute multi-turn encoder EAM58 series has good performance against mechanical damage and can withstand higher axial and radial load. By using gear suite with unique algorithm to realize the compact structure and hollow shaft diameter up to  $\Phi$  15mm. The special processing chip with high accuracy and high stability is adopted, to ensure the single-turn resolution up to 19 bit and meet the high-precision control requirement of the field.

### Features:

- Various flanges available
- Mechanical multi-turn design
- Waterproof seal improves IP level
- Hollow shaft diameter up to  $\Phi$ 15 mm
- Metal housing for shock resistance
- Protection class IP65
- Output cable or connector available
- Various revolutions and resolutions available

### Mechanical parameters

Shaft diameter	$\Phi$ 6g6/ $\Phi$ 8g6/ $\Phi$ 10g6 mm
Hollow shaft diameter	$\Phi$ 8H7/ $\Phi$ 10H7/ $\Phi$ 12H7/ $\Phi$ 15H7 mm
Protection class	IP65
Speed	6000 r/m
Max load capacity of the shaft	
Axial load capacity	80 N
Radial load capacity	160 N
Shock resistance	50G/11 ms
Vibration resistance	10G 10...2000 Hz
Bearing life	$10^9$ revolution
Rotor moment of inertia	$1.8 \times 10^{-6}$ kgm <sup>2</sup>
Starting torque	<0.01 Nm
Body material	AL-alloy
Housing material	Zn AL-alloy
Operating temperature	-40...+80 °C
Storage temperature	-45...+85 °C
Weight	360...750 g

### Electrical parameters

Output circuit	SSI	SSI
Output driver	RS422	RS422
Resolution	Max.19 bits	Max.19 bits
Revolution	12bits	12 bits
Supply voltage	10-30 VDC	5 VDC
Power consumption (no load)	$\leq$ 200 mA	$\leq$ 200 mA
Permissible load (channel)	$\pm$ 20 mA	$\pm$ 20 mA
Pulse frequency	Max15 kHz	Max15 kHz
Signal level high	Typ.3.8 V	Typ.3.8 V
Signal level low	Max. 0.5 V	Max. 0.5 V
Rise timeTr	Max 100 ns	Max 100 ns
Fall timeTf	Max 100 ns	Max 100 ns

## Standard Absolute Multiturn Encoder EAM58

### Terminal Assignment

#### SSI

Signal	0V	+U <sub>b</sub>	+C	-C	+D	-D	ST*	V/R*	Shield
Color	WH	BN	GN	YE	GY	PK	BU	RD	⊥
12-pin	1	2	3	4	5	6	7	8	PH

ST: Reset input, the current position value is stored as new zero position

VR: Up/down input, as this input is active, decreasing code values are transmitted when shaft turning clockwise.

### Operating principle

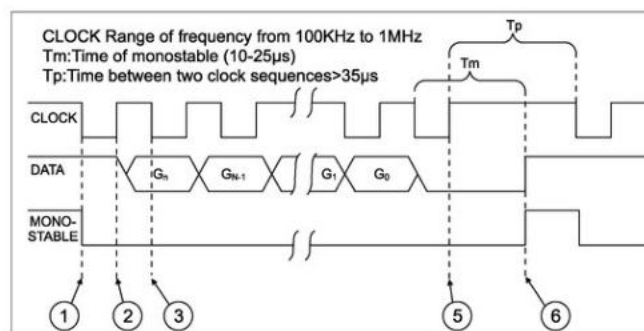

In rest conditions, the CLOCK and DATA lines are at a high logical level and the mono-stable circuit is disabled (high level).

1. On the first CLOCK signal descent front, the mono-stable is activated and the parallel value present at the input to the P/S converter is memorized in the shift register.
2. On the CLOCK signal ascent front, the most significant bit (MSB) is placed in the output on the DATA line.
3. On the CLOCK descent front when the signal is stable the controller acquires the level from the DATA line, which is the value of the most significant bit (MSB), the mono-stable is re-activated.
4. On each further ascent front of the CLOCK impulse sequence, the successive bits up to the least significant one are placed in the output on the DATA line and acquired by the control on the descent front.
5. At the end of the CLOCK impulse sequence when the external control has also acquired the value of the least significant (LSB) the CLOCK impulse sequence is interrupted and therefore the mono-stable is no longer re-activated.
6. Once the mono-stable time (Tm) has elapsed, the DATA line returns to a high logical level and the mono-stable disables itself.

### Dimensions (mm)

#### EAM58B

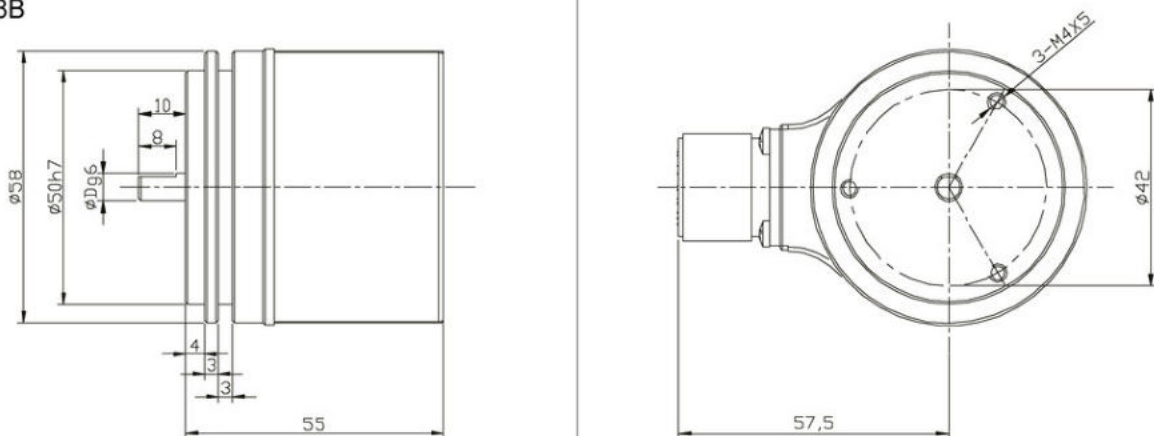

## Standard Absolute Multiturn Encoder EAM58

### Dimensions (mm)

#### EAM58C

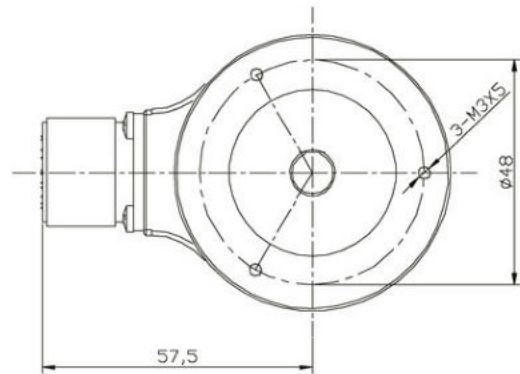
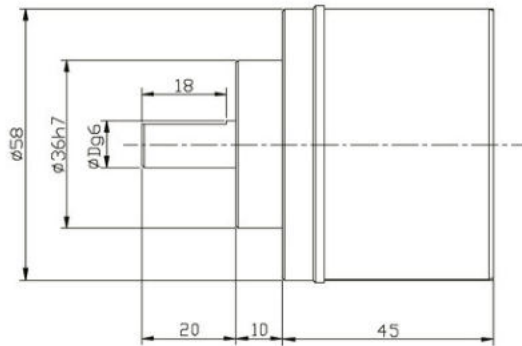

#### EAM58W

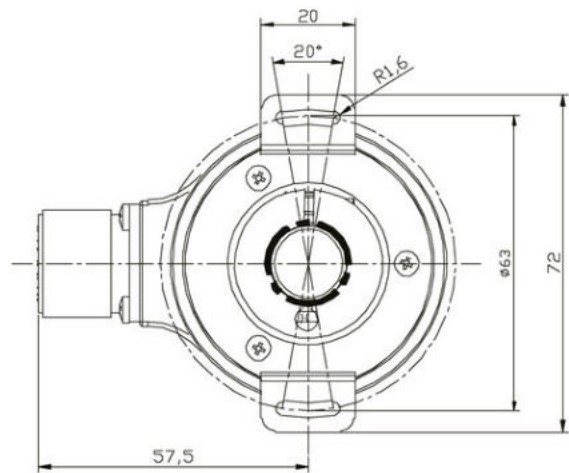
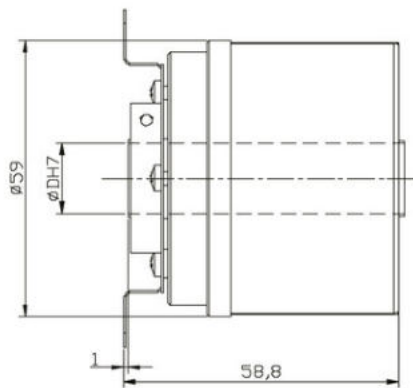

## Standard Absolute Multiturn Encoder EAM58

### Order Code

EAM
58
C
10
—
G
S6
X
PC
R
—
4096/8192
EUND

**Shaft/Hollow Shaft diameter**

Only for flange type 58B、58C  
 6=Φ6g6mm  
 8=Φ8g6mm  
 10=Φ10g6mm

Only for flange type 58W  
 8=Φ8H7mm  
 10=Φ10H7mm  
 12=Φ12H7mm  
 15=Φ15H7mm

**Outlets direction**

R=radial

Standard absolute multiturn

**Resolution**

revolution/singleturn resolution  
 revolution: 12bits  
 resolution: max. 19bits

**Type of connection**

PC=12-core cable(SSI), standard length 1.5m  
 T=M23, 12-pin connector(SSI)

**Output logic**

X= No definition(SSI)

**Output & Supply voltage**

S6=SSI(synchro serial interface) 10...30 VDC  
 S5=SSI(synchro serial interface) 5 VDC

**Code type**

G=Gray  
 B=Binary

**Flange type**

B = synchro flange, shaft length 10mm  
 C = Φ36 clamping flange, shaft length 20mm  
 W = blind hollow shaft flange, double-winged spring leaf installation

**Housing diameter**

58 = Φ58

**Series**

EAM = standard absolute multiturn

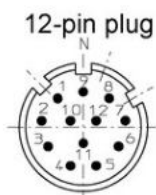

Connection accessories

Connection matching with "T" wiring

Ordering code: TMSP1612F

This sample is for reference only, take products as the standard

## Profibus-DP Interface Absolute Multiturn Encoder EAM58



### Description:

Profibus protocol absolute multi-turn encoder EAM58 series has good performance against mechanical damage and can withstand higher axial and radial load. Various flanges could meet different requirements. The product adopts high precision and high stability chip to ensure the maximum single-turn resolution 13bit, which can meet the accuracy control requirement of field.

### Features:

- Various flanges available
- Pre-screw hole, convenient for usage
- Waterproof seal improves IP level
- Cable output, convenient for installation and maintenance
- Protection class IP65
- Metal housing for shock resistance
- Conforming to Profibus-DP protocol, programmable revolution and resolution

### Mechanical parameters

Shaft diameter	Φ6g6/Φ8g6/Φ10g6 mm
Hollow shaft diameter	Φ8H7/Φ10H7/Φ12H7/Φ15H7 mm
Protection class	IP65
Speed	6000 r/m
Max.load capacity of shaft	
Axial	80 N
Radial	160 N
Shock resistance	50G/11 ms
Vibration resistance	10G 10...2000 Hz
Service life of bearing	10 <sup>9</sup> revolution
Rotor moment of inertia	1.8×10 <sup>-6</sup> kgm <sup>2</sup>
Starting torque	<0.01 Nm
Body material	AL-alloy
Housing material	ZnAl-alloy
Operating temperature	-40...+80 ℃
Storage temperature	-45...+85 ℃
Weight	360...750 g

### Electrical parameters

Revolution	4096 (12 bits)
Resolution/revolution	8192 (13 bits)
Supply voltage	10...30 Vdc
Power consumption (no load)	300 mA
Baud rate	12 Mbaud
Linearity	+/- 1/2 LSB
Output frequency	Max 100 KHz

### Terminal Assignment

+V	Supply voltage ( 24 VDC )
0V	Ground
A	Profibus-DPline output ( GN )
B	Profibus-DPline output ( RD )
A	Profibus-DPline input ( GN )
B	Profibus-DPline input ( RD )

## Profibus-DP Interface Absolute Multiturn Encoder EAM58

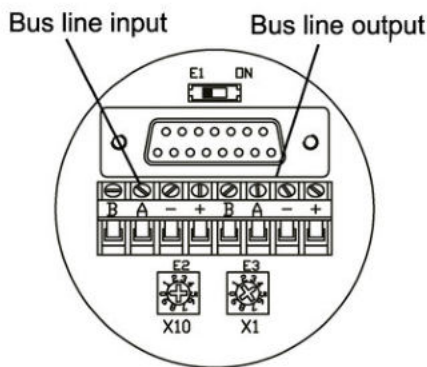

Terminal block

E1: Terminal setting switch - the default is OFF  
If the encoder is a terminal device, dial the DIP switch to ON, with the resistance of 120Ω.

E2\E3: Address setting switch  
Set in decimal combination. As shown in the figure, the default address is 4.

### Connection

V+	Supply voltage
GND	Ground
B	Profibus-DP line input (RD)
A	Profibus-DP line input (GN)
B	Profibus-DP line output (RD)
A	Profibus-DP line output (GN)

### Introduction

Profibus-DP interface absolute multiturn encoder (Identification number 0x0CCA) is complying to the Profibus-DP standard as described on the European Standard EN 50170 volume 2. The encoders are according to "Profibus Profile for Encoders, Order No. 3062". The Profibus-DP interface maintains the same maximum resolution and characteristics (16384 position/ revolution, 16384 revolution) of the stand-alone version and adds the plus of the Profibus-DP network..

By the Profibus-DP network is possible:

- During the periodic data exchange, getting the indication of the angular position from the encoder.
- Setting the resolution and the revolution (refer to corresponding paragraph for parameter setting).
- Changing the default increase direction (CW/CCW converting for parameter resetting).
- To perform the Preset operation (Set the encoder to read a specific position).
- Reading the diagnostic operating mode.
- Getting info about the code supplied by the device.

From the device it is possible:

- To display the ON/OFF status.
- To display the device activity on the bus.
- Reset function
- Setting the device address.
- If required, inserting in the bus the terminal resistance.
- Inverting the counting direction

### Equipment installation

Installing the Profibus-DP encoder in a network requires the execution of the standard steps necessary for configuring any Profibus-DP slave. The sequence of steps is as follows:

- 1- Commissioning the slave on the master (see corresponding paragraph).
- 2- Wiring the encoder into the Profibus network using or not terminations depending on the physical position the device has in the bus.
- 3- Directly set the address (which must be unique in the network and the same as the one chosen in point 1) for the slave.
- 4- Preparing the master side application and setting up the Profibus network.

On the back cover of the encoder there is a LED inspection window. The device operating status can be controlled by the two LED through the window. The green one shows the power presence and must be permanently switched on. The red LED switches off only during the periodic data exchange between the Profibus master and the encoder.

### Network specifications

Usually, an A type cable is used to wire a DP/FMS network. This cable has to have the following characteristics

Parameter	A type cable
Characteristic resistance (Ω)	135...165 at a certain frequency (3...20Mhz)
Rated capacity (PF/m)	<30
Loop resistance (Ω/Km)	<=110
Core diameter (mm)	>0.64*
Core cross-section (mm <sup>2</sup> )	>0.34*

This cable allows an optimum network utilization. In fact, it is possible to reach the maximum communication speed allowed (12Mbaud). However, there are some limitations due to the maximum physical dimensions of a bus segment as follows

kbaud	9.6	19.2	93.75	187.5	500	1500	12000
Range/Segment	1200m	1200m	1200m	1000m	400m	200m	100m

Finally, mainly physical specifications of Profibus network are perceived.



## Profibus-DP Interface Absolute Multiturn Encoder EAM58

EAM58W

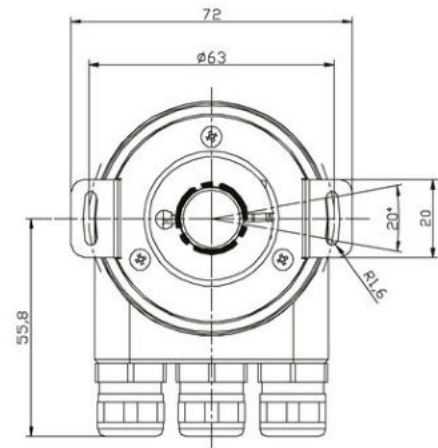
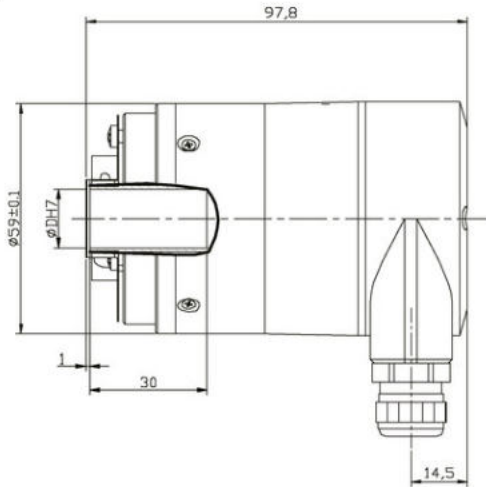

### Order Code

**EAM 58 C 10 - B F6 X X R - 4096/8192 DPND**

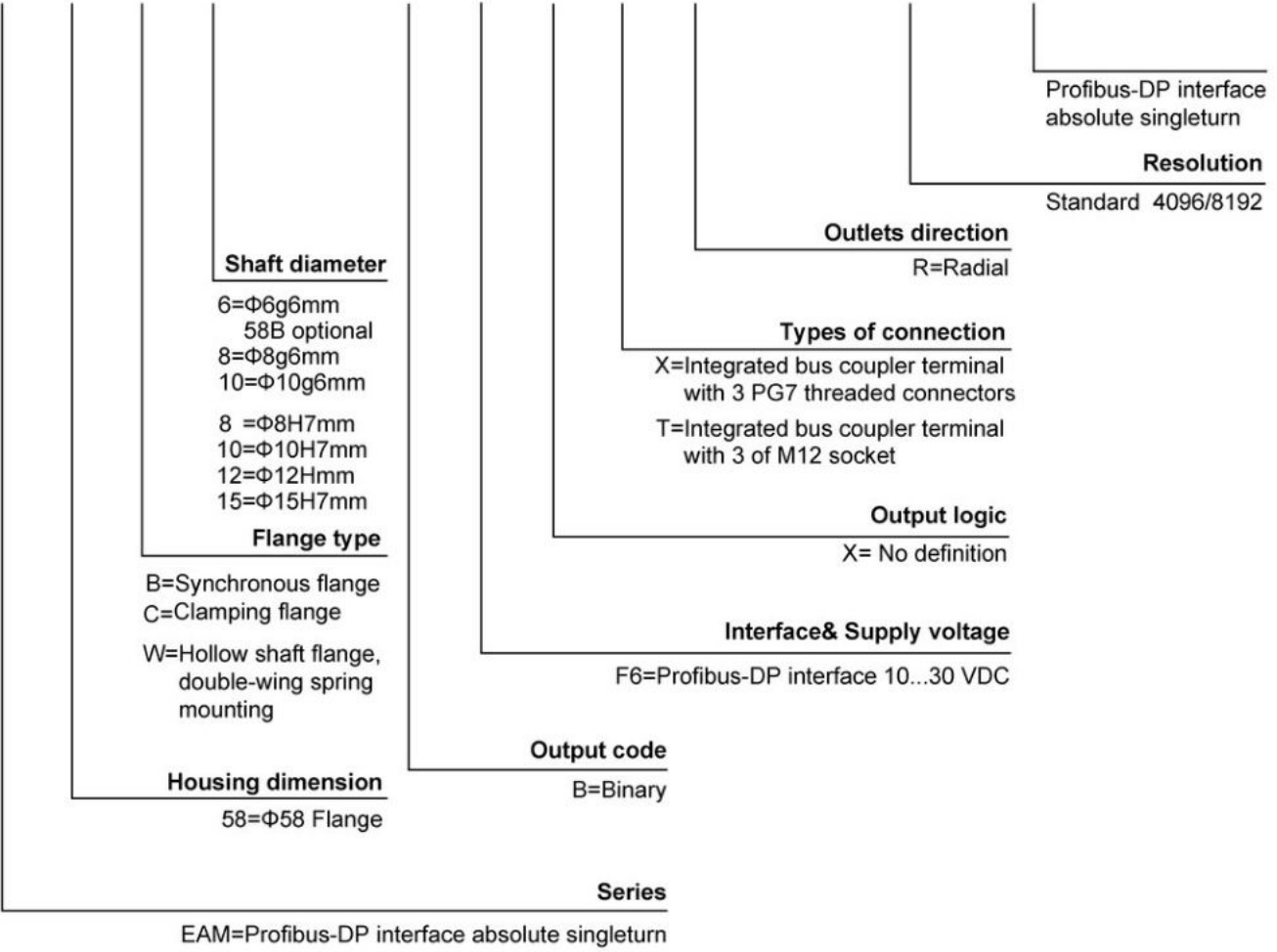

## Profinet Absolute Multiturn Encoder



### Description:

Profinet absolute multiturn encoder has good performance against mechanical damage and can withstand higher axial and radial load. Various flanges could meet different requirements, conforming to Profinet IO protocol to ensure the max. resolution of 262144 and max. revolution of 4096, which can be adjusted according to customer's field requirements. Its high speed communication and good anti-interference ability make the operation of customer's equipment more stable.

### Features:

- 4 × LED status indicator, easy-to-read monitoring status
- 3 × M12 connector, fast connection
- PROFINET IO/RT has the function of intelligent diagnosis and high-speed data transmission
- Application parameters are configured via software to facilitate debugging and maintenance
- High speed data transmission, update time  $\leq 1$ ms

### Mechanical parameters

Shaft diameter	$\Phi 6g6$ mm -58B	$\Phi 10g6$ mm -58C
Hollow shaft diameter	$\Phi 10H7$ mm	-58W
Protection class	IP65	
Max. speed (r/m)	6000	
Shaft load(axial)	40 N	
Shaft load(radial)	80 N	
Shock resistance	50G/11 ms	
Vibration resistance	10G 10...2000 Hz	
Bearing life	$10^9$ revolution	
Moment of inertia	Approx. $1.8 \times 10^{-6}$ kgm <sup>2</sup>	
Starting torque	<0.05 Nm	
Housing material	Al-alloy UNI 9002/5 -(D11S)	
Cover material	Al-alloy 6060	
Flange material	Al-alloy UNI 9002/5 -(D11S)	
Operating temperature	-40...+80 °C	
Storage temperature	-45...+85 °C	
Weight	~600 g	

### Electrical parameters

Max. revolution	4096 (12 bits)
Max. resolution	262144 (18 bits)
Supply voltage	10...30 VDC
Current consumption (no load)	200 mA
Max. rate	100 Mbits/s
Linearity	12 bits+/- 1/2 LSB
Interface	PROFINET IO/RT Class C
Data transmission rate	10/100 Mbit/s
Encoder sub-protocol	V4.1 Class3



# Profinet Absolute Multiturn Encoder

## Dimensions (mm)

EAM58W Axial

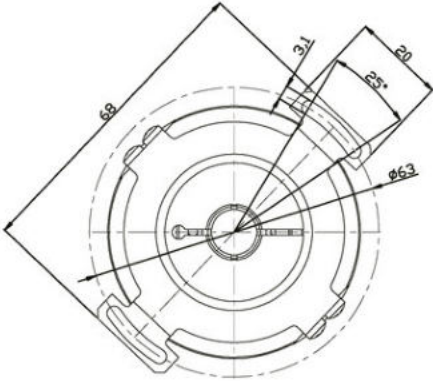
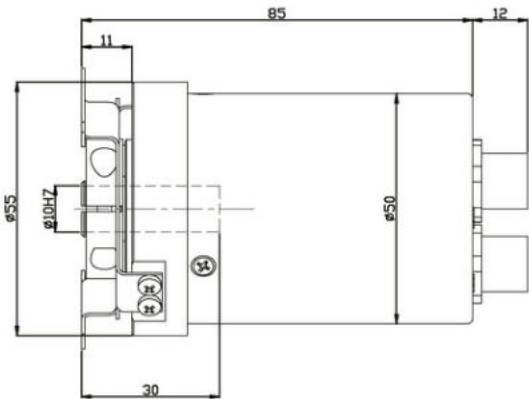

EAM58B Radial

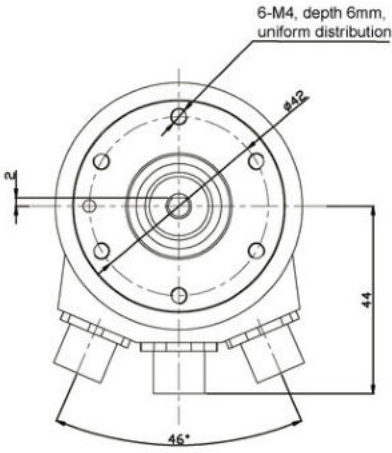
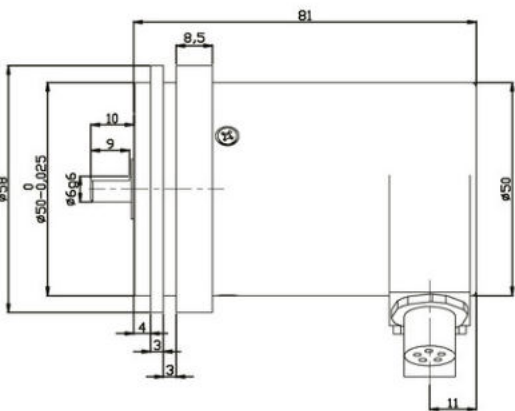

EAM58C Radial

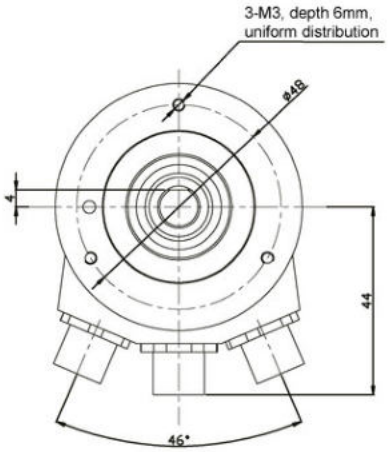
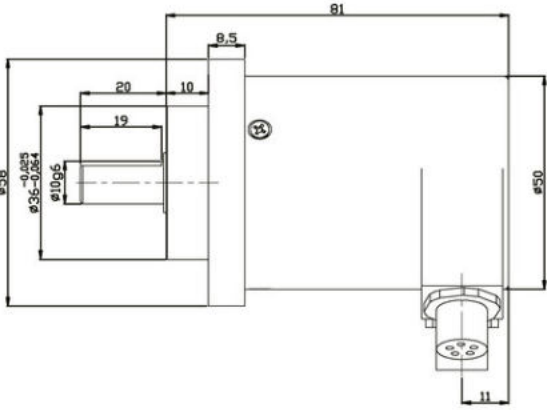

## Profinet Absolute Multiturn Encoder

### Dimensions (mm)

EAM58W Radial

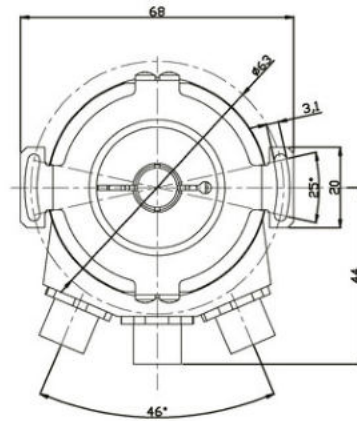
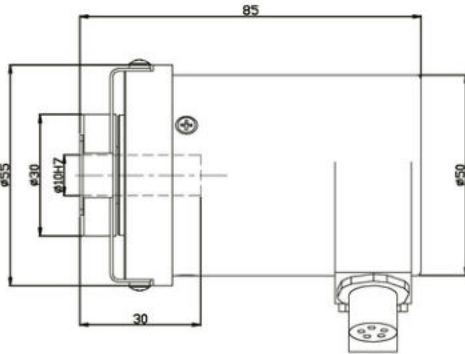

### Order Code:

**EAM 58 C 10 - B F6 X T R - 4096/8192PNOM . X X X X**

<b>Series</b> EAM = Profinet absolute multiturn encoder	<b>Housing dimension</b> 58 = $\Phi 58$	<b>Shaft/hollow shaft diameter</b> 6 = $\Phi 10g6mm$ —50B 10 = $\Phi 10g6mm$ —50C 10 = $\Phi 10H7mm$ —50W	<b>Flange type</b> B = Synchronous flange, shaft length:10mm C = $\Phi 36$ Clamping flange, shaft length:20mm W = Blind hole hollow shaft flange, double wing spring plate installation	<b>Output code</b> B=Binary	<b>Output logic</b> R= Radial X= Axial	<b>Output and Supply voltage</b> F6=Profinet IO 10...30Vdc	<b>Types of connection</b> T= Integrated bus coupler terminal with 3 of M12 socket	<b>Outlets direction</b> No definition	<b>Resolution</b> Standard 4096/8192(25Bits) Optional 4096/262144(30Bits)	<b>PNOM: Profinet RT</b>	<b>XXXX=Special code</b>
--	--	--	--	--------------------------------	--	---	---	---	---	--------------------------	--------------------------

Matching connector code:  
 Power terminal connector: TMSP 12F-F4  
 Bus input connector: TMSP 12FD-M4  
 Bus output connector: TMSP 12FD-M4

## Profinet Protocol Absolute Multi-turn Encoder EAM58



### Description:

Profinet protocol absolute multi-turn encoder EAM58 series has good performance against mechanical damage and can withstand higher axial and radial load. Various flanges could meet different requirements. The product adopts high precision and high stability chip to ensure the maximum single-turn resolution 18 bit, which can meet the accuracy control requirement of field.

### Features:

- Various flanges available
- Waterproof seal improves IP level
- 3\*M12 connector output, convenient for installation and maintenance
- Protection class IP65
- Metal housing for shock resistance
- Conforming to industrial Profinet RT & IRT protocol and programmable

### Mechanical parameters

Shaft diameter	Φ6g6/Φ8g6/Φ10g6 mm
Hollow shaft diameter	Φ8H7/Φ10H7/Φ12H7/Φ15H7 mm
Protection class	IP65
Speed (r/m)	6000
Max.load capacity of shaft	
Axial	80 N
Radial	160 N
Shock resistance	50G/11 ms
Vibration resistance	10G 10~2000 Hz
Service life of bearing	10 <sup>9</sup> revolution
Rotor moment of inertia	1.8×10 <sup>-6</sup> kgm <sup>2</sup>
Starting torque	<0.01Nm
Body material	AL-alloy
Housing material	Zn Al-alloy
Operating temperature	-40...+80 ℃
Storage temperature	-45...+85 ℃
Weight	360...750 g

### Electrical parameters



Interface	Profinet
Programming function	Resolution, speed value, counting direction, preset value
Transmission speed	10/100 Mbit
Interface period time	>1ms
No. of turns	4096 (12 bits)
Single-turn resolution	8192 (13 bits, MAX.18bits)
Supply voltage	10~30 Vdc
Current consumption	≤230 mA-10V DC, ≤100 mA-24V DC
Total power	≤2.5 W
Start time	<250 ms
Precision (INL)	±0.0439°

### Electrical connection

Connection direction	Radial
Bus interface 1	M12, female, 4-pin, D-coded
Power interface	M12, male, 5-pin, A-coded
Bus interface 2	M12, female, 4-pin, D-coded

## Profinet Protocol Absolute Multi-turn Encoder EAM58

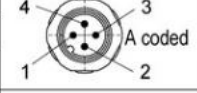
### Terminal Configuration

Function	M12 connector					
Bus interface1	Signal	Data sending+	Data receiving+	Data sending -	Data receiving -	
	Abbreviation	TxD+	RxD+	TxD-	RxD-	
	Pin	1	2	3	4	
Power interface	Signal	Voltage +	-	Voltage -	-	
	Abbreviation	+ V	-	0 V	-	
	Pin	1	2	3	4	
Bus interface2	Signal	Data sending+	Data receiving+	Data sending -	Data receiving -	
	Abbreviation	TxD+	RxD+	TxD-	RxD-	
	Pin	1	2	3	4	

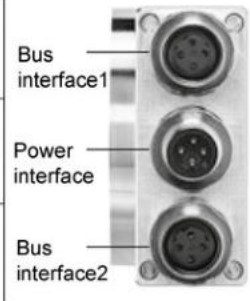

### Dimensions (mm)

#### EAM58B

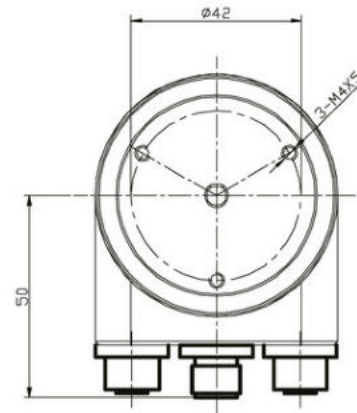
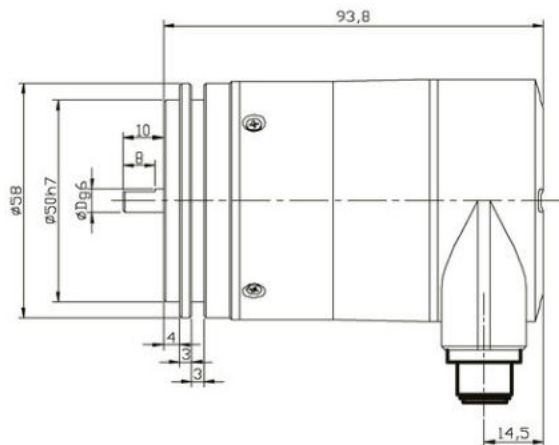

#### EAM58C

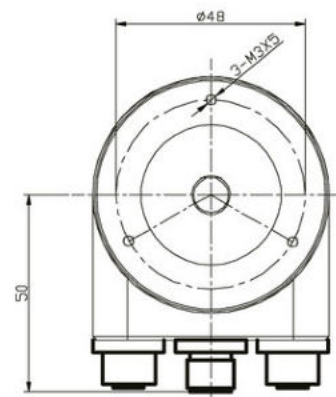
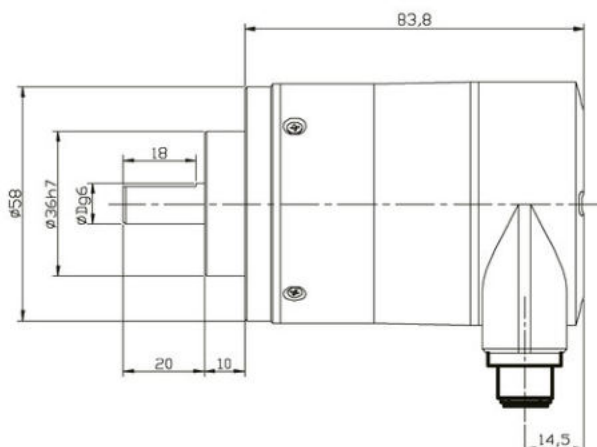



## EtherNet/IP Interface Absolute Multiturn Encoder EAM58



### Description:

EtherNet/IP interface absolute multiturn encoder EAM58 series has good performance against mechanical damage and can withstand higher axial and radial load. Various flanges could meet different requirements. It complies with common industrial protocol, max resolution 8192, max revolution 4096. The resolution and revolution can be set in accordance with customer requirements. High speed communication and anti-interference ensure stable operation.

### Features:

- Various flanges available
- Waterproof seal improves IP level
- Connector output, convenient for installation and maintenance
- Protection class IP65
- Metal housing for shock resistance
- Conforming to Common Industrial Protocol, programming functions

### Mechanical parameters

Shaft diameter	Φ6/Φ8/Φ10g6 mm (Solid Shaft)
Hollow Shaft diameter	Φ8/Φ10/Φ12/Φ15H7 mm
Protection class	IP65
Max. Permissible Mechanical Speed	6000 r/min
Max. Shaft load	Axial 40 N, Radial 110 N
Shock resistance	≤100 g (half sine 6ms, EN60068-2-27)
Vibration resistance	≤10g (10Hz - 1000Hz, EN60068-2-6)
Bearing life	10 <sup>9</sup> revolution
Rotor moment of inertia	≤30 gcm <sup>2</sup>
Starting torque	≤3 Ncm
Body material	Aluminum
Housing material	Steel with cathodic corrosion protection
Flange material	Aluminum
Operating temperature	-40...+85 C
Storage temperature	-45...+85 C
Weight	~400 g

### Electrical parameters



Interface	EtherNet/IP
Programming Functions	Resolution, time base and filter for velocity, preset, counting direction, IP-Adress
Transmission Rate	10/100 Mbit
Interface Cycle Time	>1 ms
Revolution	4096 (12 bits)
Resolution/revolution	8192 (13 bits)
Supply voltage	10...30 VDC
Current Consumption	≤230 mA-10 VDC, ≤100 mA-24 VDC
Power Consumption	≤2.5 W
Start-Up Time	<250 ms
Accuracy (INL)	±0.0439°

### Electrical Connection

Connection Orientation	Radial
Bus Port 1	M12, Female-4 pin, D-coded
Power Supply	M12, Male-4 pin, A-coded
Bus Port 2	M12, Female-4 pin, D-coded

# EtherNet/IP Interface Absolute Multiturn Encoder EAM58

## Terminal Assignment

Function	M12 connector					
Bus Port 1	Signal:	Transmit data+	Receive data+	Transmit data-	Receive data-	 D coded
	Abbreviation:	TxD+	RxD+	TxD-	RxD-	
	Pin Number:	1	2	3	4	
Power Supply	Signal:	Voltage +	-	Voltage -	-	 A coded
	Abbreviation:	+ V	-	0 V	-	
	Pin Number:	1	2	3	4	
Bus Port 2	Signal:	Transmit data+	Receive data+	Transmit data-	Receive data-	 D coded
	Abbreviation:	TxD+	RxD+	TxD-	RxD-	
	Pin Number:	1	2	3	4	

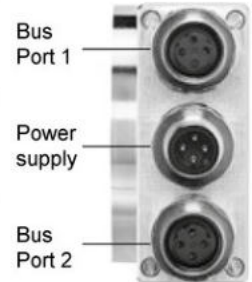

## Dimensions (mm)

### EAM58B

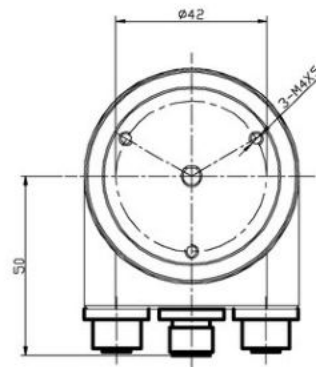
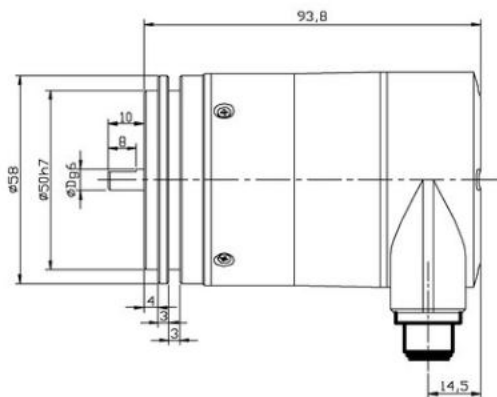

### EAM58C

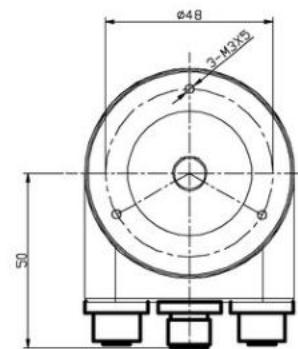
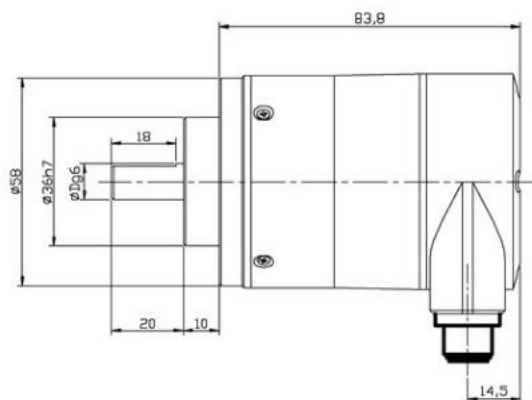

## EtherNet/IP Interface Absolute Multiturn Encoder EAM58

### Dimensions (mm)

EAM58W

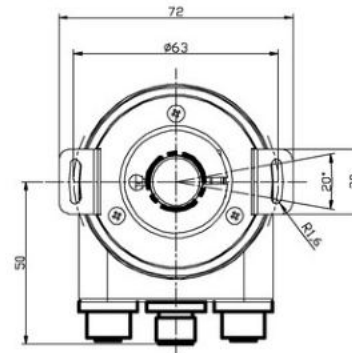
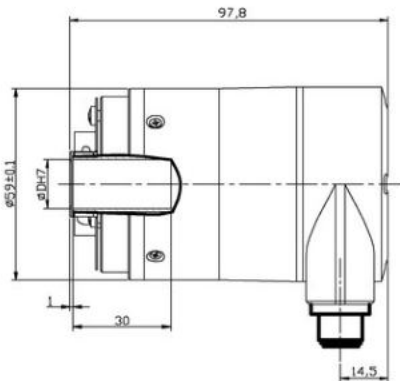

### Order Code:

**EAM 58 C 10 - B F6 X T R - 4096/8192 ENND**

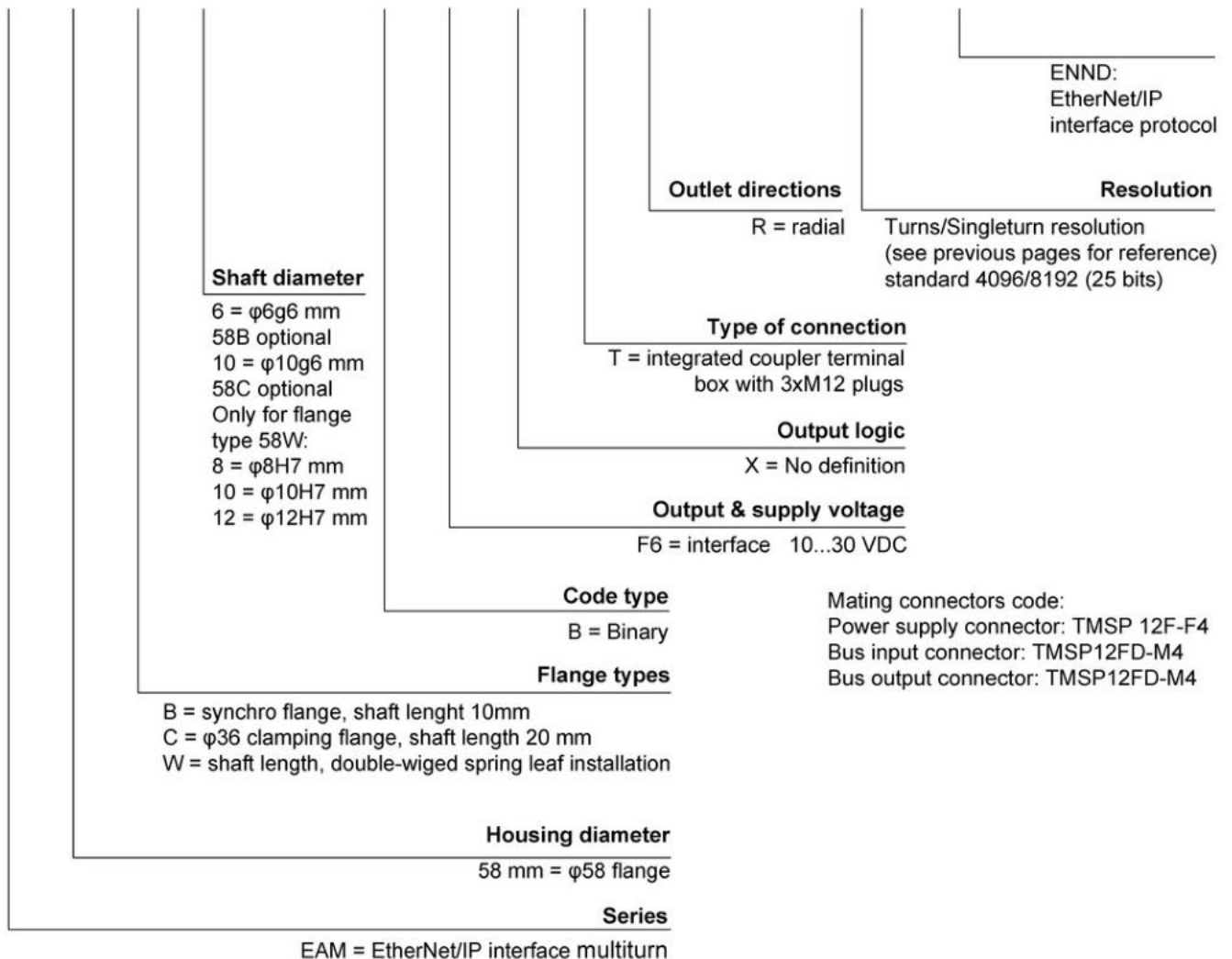

## EtherCAT Interface Absolute Multiturn Encoder EAM58



### Description:

The Ethercat interface absolute multiturn encoder EAM58 series has a good resistance to mechanical damage and can withstand higher axial and radial loads. Various types of flanges can be used to meet different requirements. It complies with industrial Ethercat interface protocol and has a max. resolution of 8192 and a max. revolution of 4096. The resolution and revolution can be programmed according to customer requirements. The high speed communication and anti-interference features ensure steady performance during operation.

### Features:

- 4 status indicators, for a fast and accurate understanding of the product status
- 3xM12 connectors, implement a fast connection
- Industrial Ethercat interface with an intelligent diagnosis and high speed data transmission function
- Software configures the application of various parameters - convenient maintenance
- Faster interface cycle time

### Mechanical parameters

Shaft Diameter	φ6g6 mm	-58B
	φ10g6 mm	-58C
Hollow Shaft Diameter	φ8H7/ φ10H7/ φ12H7 MM	-58W
Protection class	IP65	
Speed	6000 r/m	
Axial load capacity	40 N	
Radial load capacity	80 N	
Shock resistance	50G/ 11 ms	
Vibration resistance	10G 10...2000 Hz	
Bearing life	10 <sup>9</sup> revolution	
Rotor moment of inertia	approx. 1.8x10 <sup>-6</sup> kgm <sup>2</sup>	
Starting torque	0 < .05 Nm	
Body material	AL UNI 9002/5 -(D11S)	
Housing material	AL 6060	
Flange material	AL UNI 9002/5 -(D11S)	
Operating temperature	-40...+80 C	
Storage temperature	-45...+85 C	
Weight	600 g	

### Electrical parameters

Interface	Ethercat
Profile	CoE (CANopen over EtherCAT, DS-301 + DS-406)
Programming Functions	Resolution, preset, counting direction
Supply voltage	10...30 VDC
Current consumption (without load)	200 mA
Power Consumption	≤ 2.5 W
Max. bus rate	100 Mbits/s
Interface cycle time	≥ 62.5 μs
Code	Binary
Max. number of laps	4096 (12 bits)
Max. resolution	8192 (13 bits)

## EtherCAT Interface Absolute Multiturn Encoder EAM58

### Terminal configuration

Data port 1:

Signal	TxD+	RxD+	TxD-	RxD-	
Needle number	1	2	3	4	

Power port:

Signal	+V	—	-V	—	
Needle number	1	—	3	—	

Data port 2:

Signal	TxD+	RxD+	TxD-	RxD-	
Needle number	1	2	3	4	

### Dimensions (mm)

EAM58B

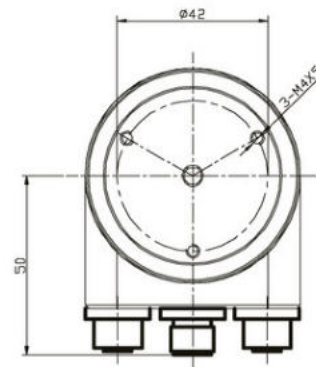
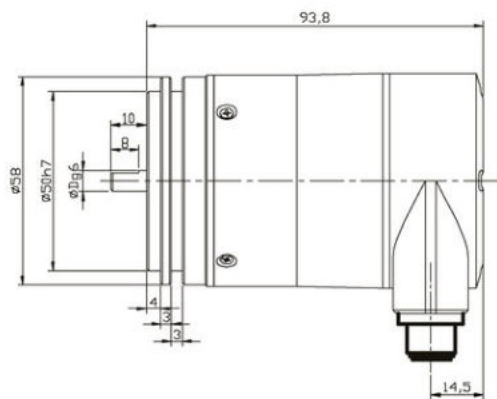

EAM58C

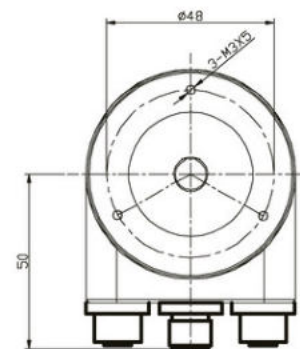
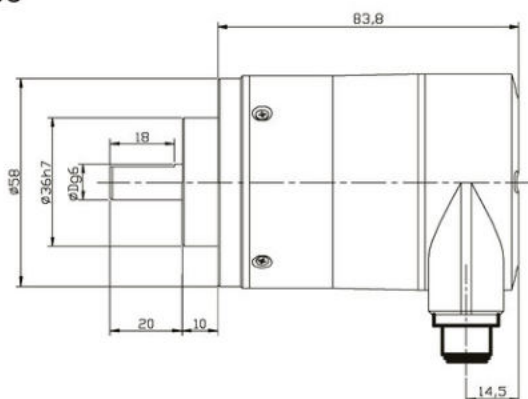

# EtherCAT Interface Absolute Multiturn Encoder EAM58

## Dimensions (mm)

EAM58W

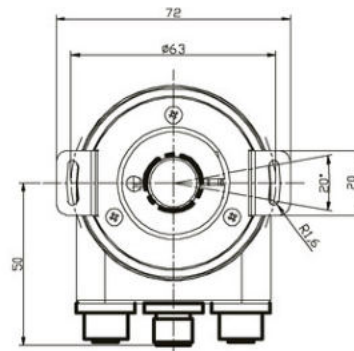
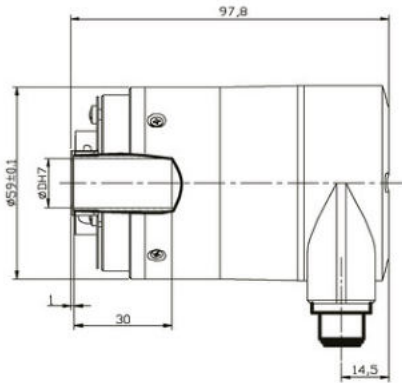

## Order Code:

**EAM 58 C 10 - B F6 X T R - 4096/8192 ECND**

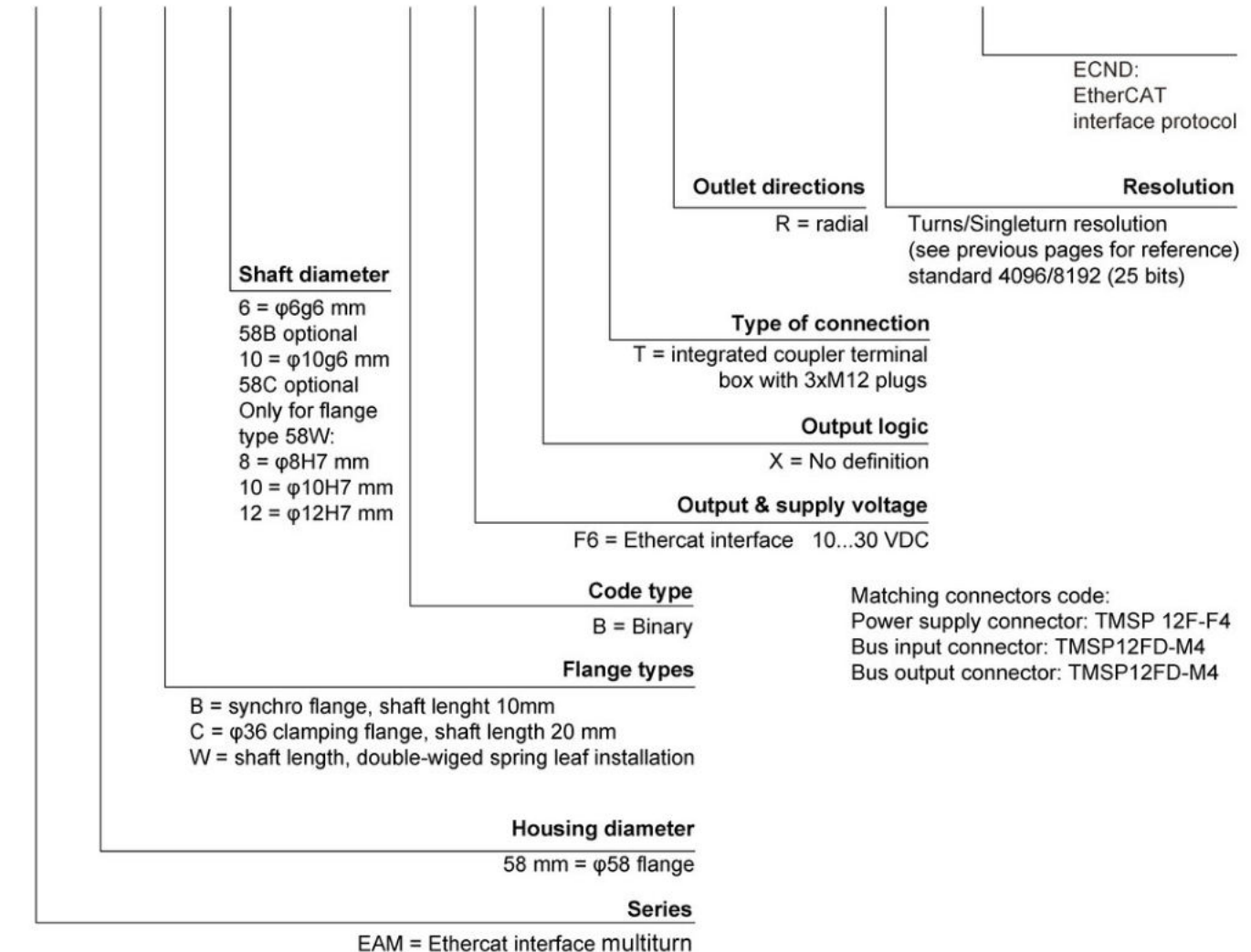

## CANopen Interface Absolute Multiturn Encoder EAM58



### Description:

EAM58 series is used in industrial environments with special needs. It has good resistance to mechanical damage and its shaft can withstand high axial and radial loads. High-speed communication and good ability make the customer's equipment run more stable. anti-interference

### Features:

- Various types of flanges are available
- Waterproof seal improves IP level
- Protection class IP65
- Metal housing for shock resistance
- Conforming to industrial CANopen protocol
- Pre-screw hole, convenient for usage
- Durable stainless steel shaft

### Mechanical parameters:

Shaft diameter (mm)	φ6g6φ8g6
Protection class	IP65
Max.speed (r/m)	3000
Max.load capacity of shaft	80 N(axial) 160 N(radial)
Shock resistance	50G/11 ms
Vibration resistance	10G 10...2000Hz
Bearing life	10 <sup>9</sup> revolution
Moment of inertia	1.8x10 <sup>-6</sup> kgm <sup>2</sup>
Starting torque	< 0.05 Nm
Body material	Al-alloy UNI 9002/5 - (D11S)
Housing material	Al-alloy 6060
Flange material	Al-alloy UNI 9002/5
Operating temperature	-40 C...+80 C
Storage temperature	-45 C...+85 C
Weight	~800 g

### Electrical parameters:

Supply voltage	10...30 V DC
Current	Max. 0.29 A
Linearity	±1/2 LSB(12 bit); ±1 LSB(13 bit)
Code	Binary
Interface	CAN HIGH-Speed to ISO/DIS 11898, Basic and Full-CAN; CAN specification 2.0 B
Protocol	CANopen Profile DSP 406 with additional function
Baud rate	250K (Pre-factory setting) CAN DNET 125 / 250 / 500 kBit/s
Add.	Add. set: 1~99 32(Pre-factory setting)
Termination resistors	220Ω

# CANopen Interface Absolute Multiturn Encoder EAM58

## Terminal Assignment

Signal	0V	+Ub	CAN+	CAN-	Shield
Color	WH	BN	GN	GY	

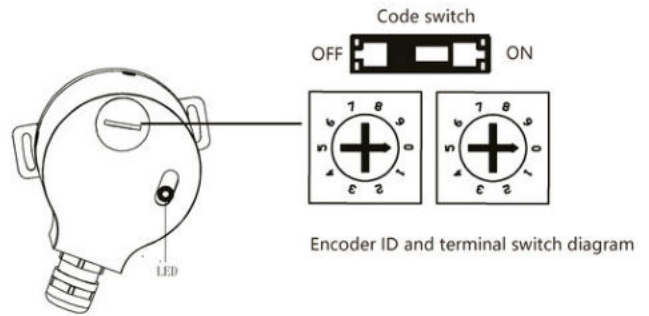

## Dimensions(mm)

### EAM58B

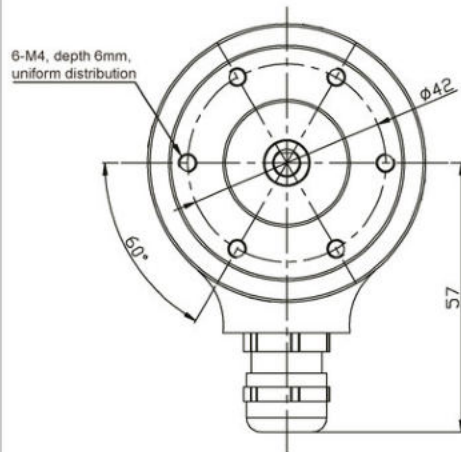
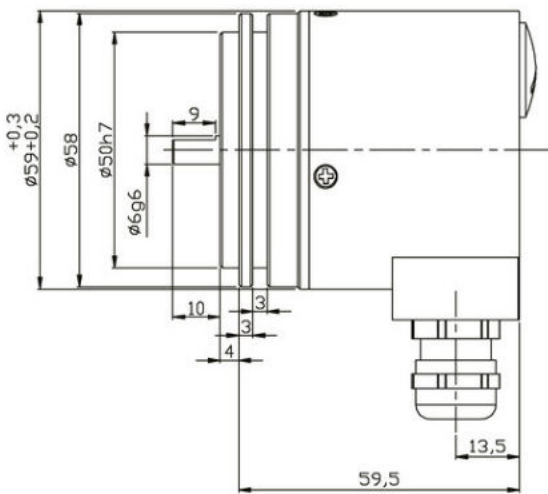

### EAM58C

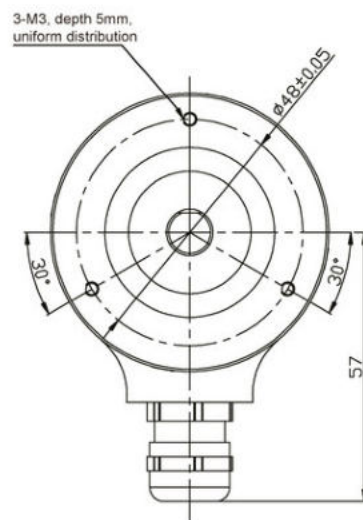
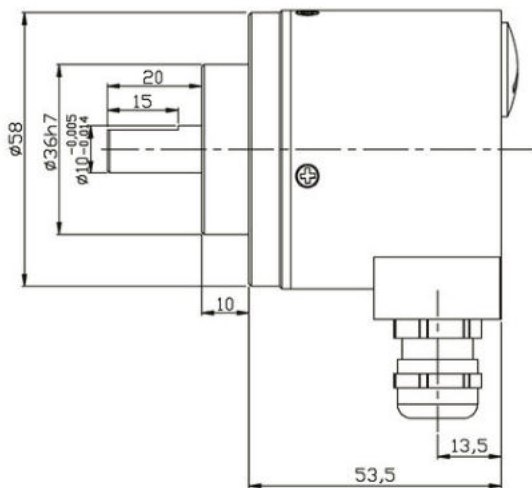



## Large Hollow Shaft Profibus-DP Interface Absolute Multiturn Encoder EAM90L



### Description

Profibus-DP interface absolute multiturn encoder EAM90L series delivers outstanding performance in withstanding mechanical damages and higher axial and radial loads. Through-hole installations and various types of shafts diameters could meet the different requirements of customers. It complies with Profibus protocol and has a maximum resolution of 16384 and revolution of 4096. The resolution and revolution can be programmed on request. Its high speed communication and anti-interference performance ensure a steady operation.

### Features

- Waterproof seal provides greater IP level
- Various types of stainless steel shafts diameters
- Metal housing for better shock resistance
- Direct cable output, convenient for installation and maintenance
- Protection class IP65
- Conforming to the Profibus protocol
- Programmable revolution and resolution

### Mechanical parameters

Shaft diameter	Φ12H7/Φ15H7/Φ20H7//Φ24H7/Φ28H7/ Φ(5/8)"H7/Φ1"H7/Φ12g6X30 mm
Protection class	IP65
Speed	Max.6000 r/m continuous Max.3000 r/m
Max load capacity of the shaft	
axial	40 N
radial	80 N
Shock resistance	2500 m/s <sup>2</sup> 6 ms
Vibration resistance	100 m/s <sup>2</sup> 10...2000 Hz
Bearing life	10 <sup>9</sup> revolution
Moment of inertia	~72 x 10 <sup>-6</sup> kgm <sup>2</sup>
Starting torque	hollow shaft < 0.2 Nm shaft < 0.05 Nm
Body material	AL-alloy
Housing material	AL-alloy
Operating temperature	-20...+80 °C
Storage temperature	-25...+85 °C
Weight	~ 900 g

Resolution  
4096 (revolution) ×8192 (resolution)  
4096 (revolution) ×4096 (resolution)  
Revolution and resolution are programmable in  
PLC (see operation manual for programming steps)

### Electrical parameters

Supply voltage(+Ub)	10...30 VDC
Power consumption	Max.0.29 A
Linearity	± 1/2 LSB ( ± 1 LSB 13/14 bit)2
Interface	RS 485
Protocols	Profibus-DP, encoder profile class 2
Baud rate	Max. 12 Mbit/s
Address	programmable via DIP switches

Conforms to CE acc. to EN 61000-6-1, EN 61000-6-4 and EN 61000-6-3  
Conforms to EMC acc. to EN 61000-4, 5

Profibus Documentations for  
field bus Encoders:

Please refer to PROFIBUS-DP  
for detailed information, i.e.  
DIN 19245-3 and EN 50170,  
and OVERVIEW for other  
information.

Programmable parameters:

- Rotation Direction
- Proportional factor
  - Single turn resolution
  - Total resolution
- Preset position
- Diagnostic mode

Encoder with integrated coupler:

- Achieving current isolation through Fieldbus DC/DC converter
- Including RS485 driver, max baud rate 12MB
- Configure Fieldbus address through DIP switch
- LED Diagnostic Display
- Equipped with Class1 & Class 2 functions

## Large Hollow Shaft Profibus-DP Interface Absolute Multiturn Encoder EAM90L

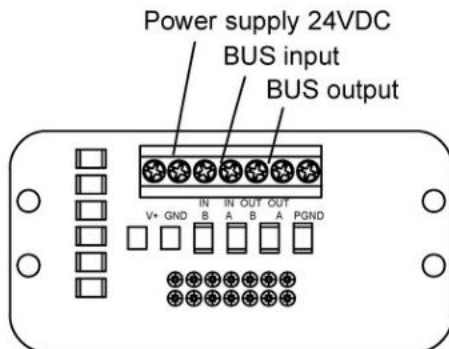

Terminal wiring block of an encoder

E2: Line close DIP switch — Default OFF  
DIP1-DIP2, the BUS is closed when setting the two switches ON, 120Ω.

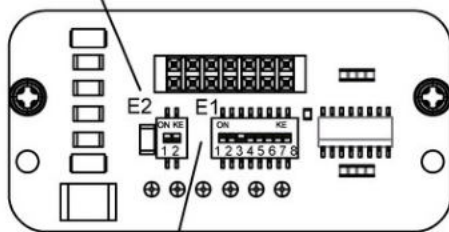

E1: Address DIP switch — DIP1- DIP7 address setting switch, binary operation, the default address is 4 as illustrated in the diagram, a maximum number of 126 addresses are acceptable in Profibus network. DIP8: CW/CCW

### Connection

V+	Supply voltage
GND	Ground
B	Profibus-DP line input (RD)
A	Profibus-DP line input (GN)
B	Profibus-DP line output (RD)
A	Profibus-DP line output (GN)

### Introduction

Profibus-DP interface absolute multiturn encoder (Identification number 0x0CCA) complies with the Profibus-DP standards as described on the European Standard EN 50170 volume 2. The encoders also conform to "Profibus Profile for Encoders, Order No. 3062".

The Profibus-DP interface maintains the same maximum resolution (16384 position per revolution, 16384 revolutions) and the features of a stand-alone unit with the bonus of the Profibus-DP network.

Through the Profibus-DP network it is able to:

- Obtain the angular position from the encoder during the periodic data exchange.
- Program the resolution and revolution (refer to corresponding chapters for parameter setup).
- Change the default incremental direction (convert between CW/CCW during parameter setup).
- Perform the Preset operation (program the encoder to read a specific position).
- Read the diagnostic status.
- Obtain info about the code came with the device.

With the device's class, it is able to:

- TDisplay the ON/OFF status.
- Display the BUS device activity on the bus.
- Reset function
- Configure the device address.
- If required, inserting the terminal resistor into the bus.
- Change the counting direction

### Installation

Installing the Profibus-DP encoder in a network requires the execution of a typical procedure necessary for configuring any Profibus-DP slave. The procedure is as follows

- 1- Commissioning the slave onto the master (see corresponding chapter).
- 2- Wiring the encoder into the Profibus network using the physical location of the device in the bus.
- 3- Configuring slave's address (which must be unique in the network and the same as the device).
- 4- Preparing applications from the master and setting up the Profibus network

On the back cover of the encoder there are two LED indicators. The device's operating status can be observed by the two LED. The green LED shows the power status and must be on constantly. The red LED only switches off during the periodic data exchange between the Profibus master and the encoder.

Note: To set and configure the slave into the Profibus-DP master it is necessary to use the "gsd" file delivered with the encoder. The file can be found on the CD.

### DIP-switches setup (configuring slave address)

Besides the address and the standard position of a terminal DIP switch, a configuration example of Profibus and the devices is illustrated below:

In this example, device's address is set up as 1001101, with the corresponding decimal address as 77. Bit 7 is the top digit, and bit 1 is the lowest digit Bit 8 is used for changing the counter direction. Bit 1 to bit 7 are used to configure encoder's address

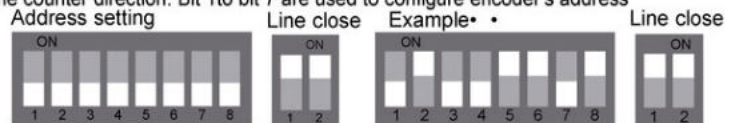

### Network Characteristics

Usually, an A type cable is used to wire a DP/FMS network. This cable has to have the following characteristics.

Parameter	A type cable
Characteristic resistance (Ω)	135... 165at a certain frequency (3...20Mhz)
Rated capacity (PF/m)	<30
Loop resistance (Ω/Km)	≤110
Core diameter (mm)	>0.64*
Core cross-section (mm <sup>2</sup> )	>0.34*

This cable allows the optimal network utilization. In fact, it is possible to reach the maximum communication speed allowed (12Mbaud). However, there are some limitations due to the maximum physical dimensions of a bus segment as follows

kbaud	9.6	19.2	93.75	187.5	500	1500	12000
Range/Segment	1200 m	1200 m	1200 m	1000 m	400 m	200 m	100 m

Finally, the physical characteristics of a Profibus network are now known.

# Large Hollow Shaft Profibus-DP Interface Absolute Multiturn Encoder EAM90L

## Dimensions (mm)

EAM90L

Accessories:  
E41350087

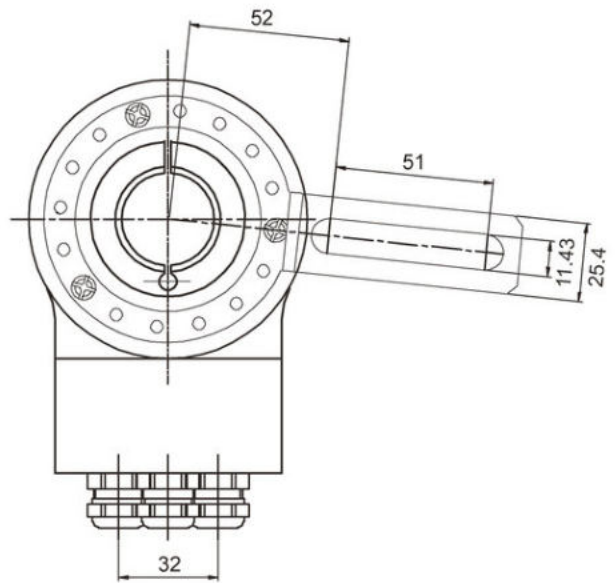
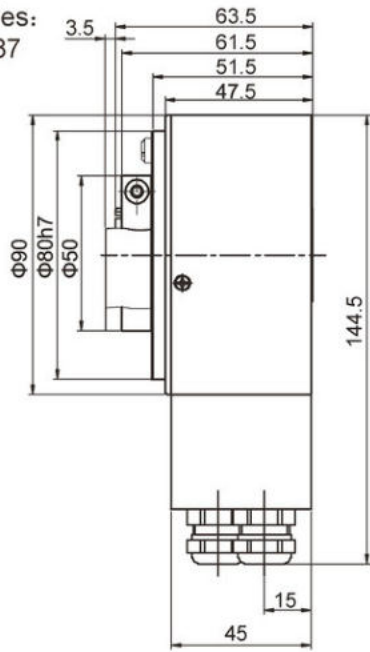

## Large Hollow Shaft Profibus-DP Interface Absolute Multiturn Encoder EAM90L

Order Code

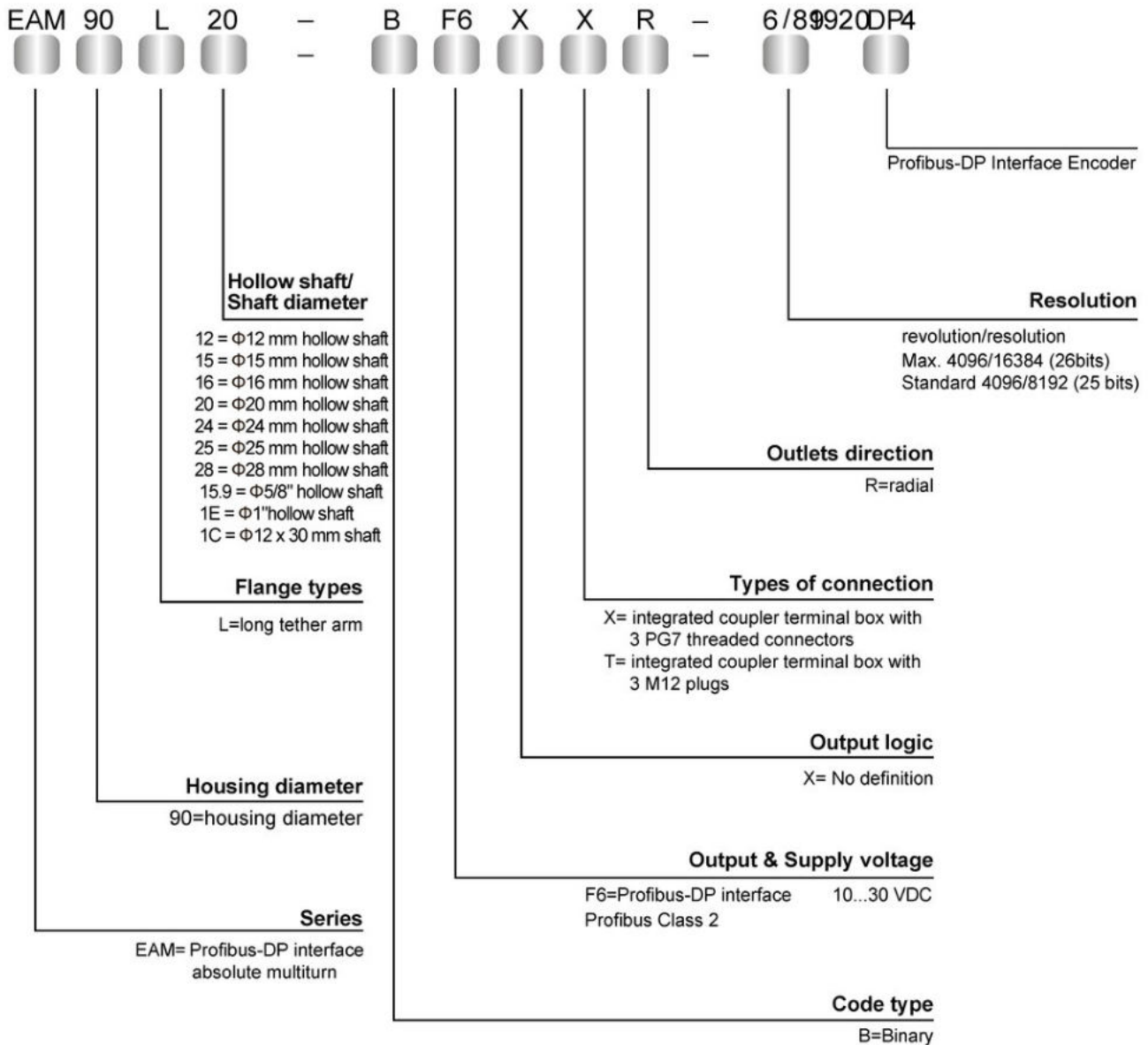

Accessories

Installation accessories

Various types of connection

Please see the enclosed CD for GSD documents and operation manual.

## Large Hollow Shaft Absolute Multiturn Encoder EAM90L

### Description

Large hollow shaft absolute multiturn encoder EAM90L series delivers good performance in withstanding mechanical damages and higher axial and radial loads. Its unique hollow shaft structure, various types of shafts diameters are available for different applications. It is equipped with resolution up to 16384(14 bit) and the RESET function.



### Features

- Gray or Binary available
- Space-saver hollow shaft design, "C" ring lock
- Durable stainless steel shaft  $\Phi 12\sim\Phi 28$  mm
- Waterproof seal provides greater IP level
- Metal housing can withstand higher axial and radial loads.
- Resolution up to 16384
- Protection class IP65
- Equipped with short-circuit and reverse connection protection
- Output cables or connectors are available for easy maintenance

### Mechanical Characteristics

Shaft diameter	$\Phi 12H7/\Phi 15H7/\Phi 20H7/\Phi 24H7/\Phi 28H7/$ $\Phi(5/8)''H7/\Phi 1''H7/\Phi 1.2g6X30$ mm
Protection class	IP65
Speed	6000 r/m
Max load capacity of the shaft	
axial	40 N
radial	80 N
Shock resistance	50G/11 ms
Vibration resistance	10G 10~2000 Hz
Bearing life	$10^9$ revolution
Moment of inertia	$1.8 \times 10^{-6}$ kgm <sup>2</sup>
Starting torque	<0.1 Nm max
Body material	AL-alloy
Housing material	AL-alloy
Operating temperature	-20°C ~ +80°C
Storage temperature	-25°C ~ +85°C
Weight	600 g

### Electrical Characteristics

Output circuit	SSI
Output driver	RS422
Resolution	14 Bits
Supply voltage	10...30 VDC
Power consumption (no load)	$\leq 200$ mA
Permissible load (channel)	$\pm 20$ mA
Pulse of frequency	Max. 1 MHz
Signal level high	Typ. 3.8 V
Signal level low	Max. 0.5 V
Rise time Tr	Max 100 ns
Fall time Tf	Max 100 ns

Available conventional resolution:

Resolution per turn:

1024, 2048, 4096, 8192, 16384

Number of turns:

1024, 2048, 4096, 8192

## Large Hollow Shaft Absolute Multiturn Encoder EAM90L

### Terminal Configuration

#### SSI Wiring Guide

Signal	0V	+Ub	+C	-C	+D	-D	ST*	VR*	⊥
Color	WH	BN	GN	YE	GY	PK	BU	RD	
12-pin	1	2	3	4	5	6	7	8	PH

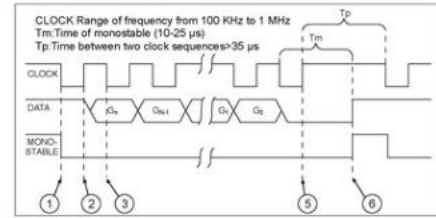

### Dimensions (mm)

EAM90L  
Accessories  
E41350087

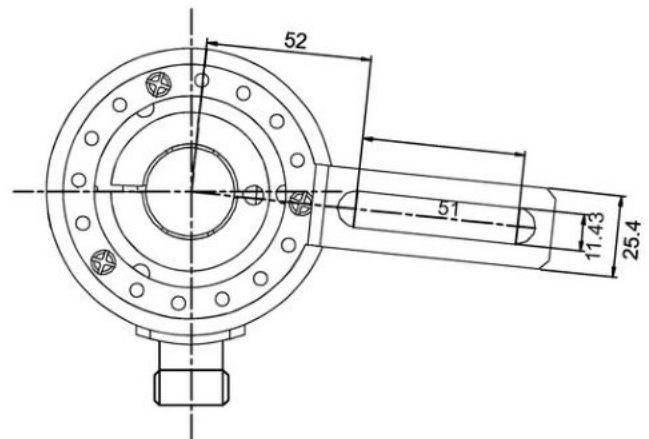
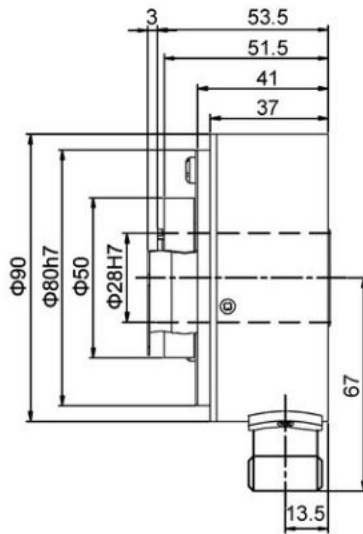

# Large Hollow Shaft Absolute Multiturn Encoder EAM90L

## Order Code

EAM 90 P 20 - G S4 X PC R - 4096/8192 SS . XXXX

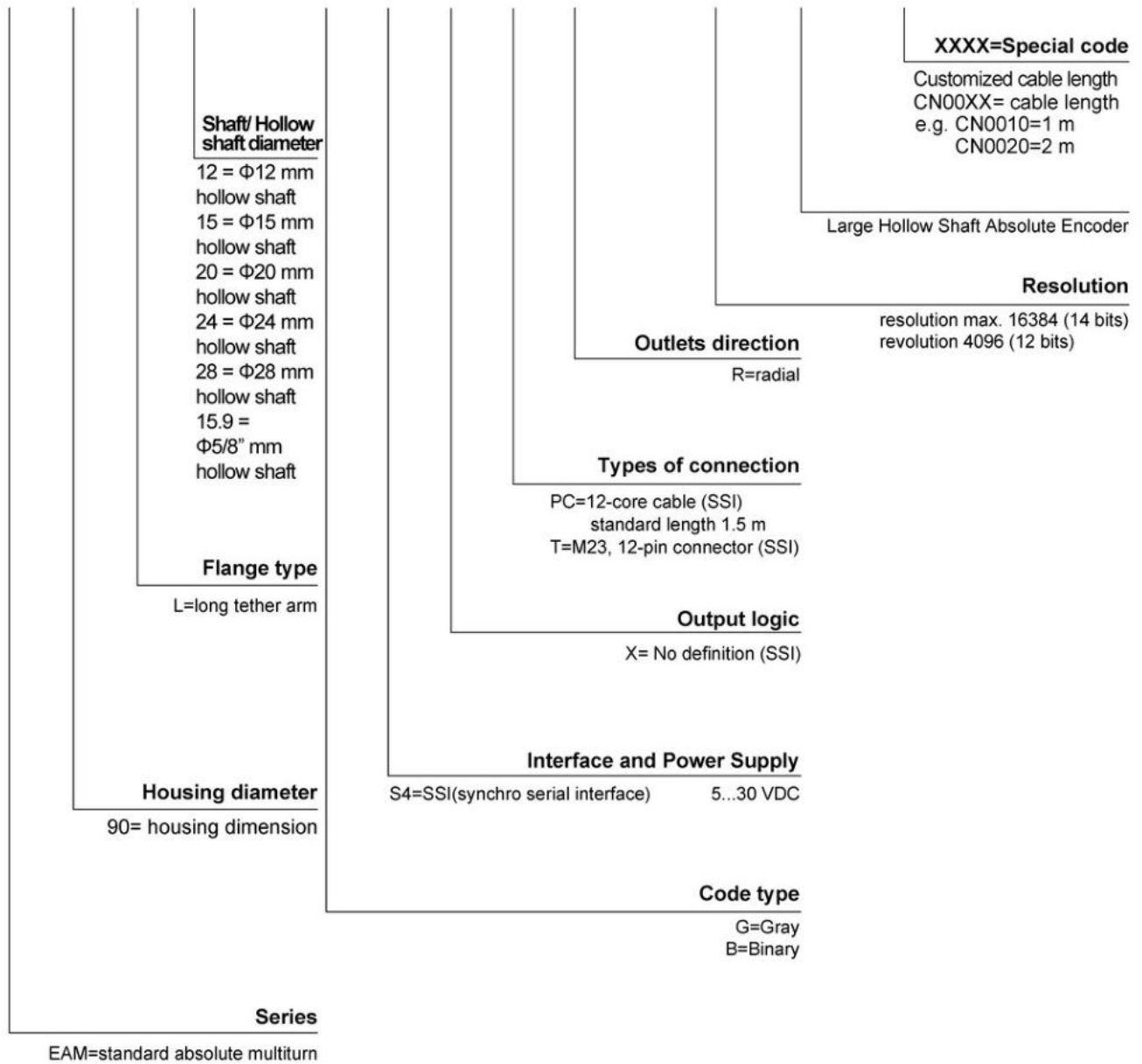

## Draw Wire Mechanics EVD Series



### Description:

Draw wire mechanics used together with encoders is designed for checking the mechanical action at certain distance. It converts the cable rotating movement into linear movement, and the encoder does the counting and ultimately transmits the signal to host computers. Standard type flange 58B is used to facilitate the connection with the encoder, the distance is up to 20 m, suitable for working in high-loaded harsh industrial environments.

### Features:

- Round universal head, reduces friction, and increases speed
- Optional flange 58B series encoder
- Compatible with a variety of encoders
- Waterproof seal improves IP level
- High repetition up to 0.05 mm
- Robust AL-alloy housing
- Max. measuring range 20 m for measuring the length and speed

### EVD series parameters:

High strength AL-alloy housing
Reliable wire winding system
Flange facilitates the connection with all encoders

### Mechanical parameters:

Measuring range	max. 3 m
Dimensions	80 x 80 mm
Length/round	200 mm
Wire diameter	1.3 mm
Device accuracy	±0.1%
Adjustable speed	4 m/s
Telescopic spring force	4-16 N
Body material	aluminium
Protection class	IP64
Wire material	stainless steel
Weight (without encoder)	1.3 kg
Working and storage temperature	-30...+70 °C

## Draw Wire Mechanics EVD Series

### Dimensions (mm)

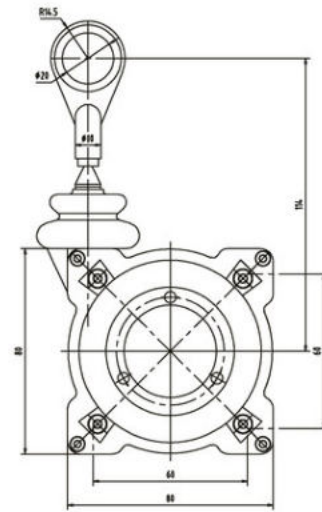
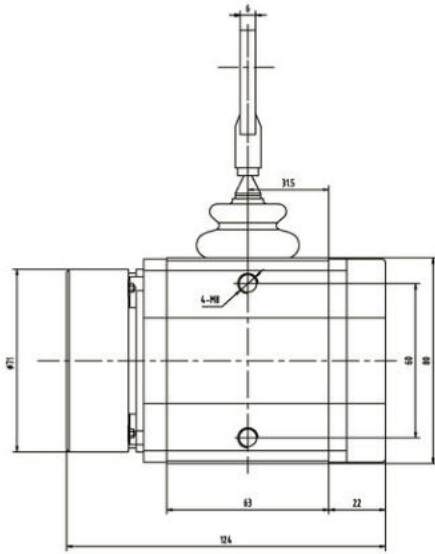

### Mechanical parameters :

Measuring range	max.6 m
Dimensions	130x130 mm
Length/round	333.34 mm
Wire diameter	1.3 mm
Device accuracy	±0.1 %
Adjustable speed	4 m/s
Telescopic spring force	4 - 16 N
Body material	aluminium
Protection class	IP64
Wire material	stainless steel
Weight (without encoder)	4.5 kg
Working and storage temperature	-30...+70 °C

## Draw Wire Mechanics EVD Series

### Dimensions (mm)

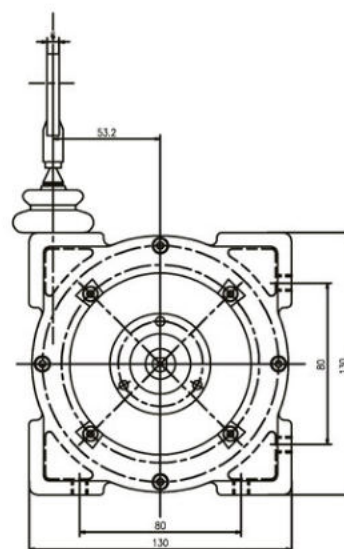
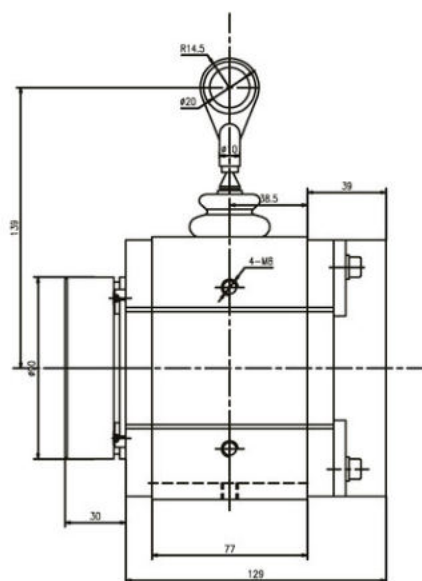

### Mechanical parameters :

Measuring range	8-10 m	15 m	20 m
Dimensions	130x130 mm	130x130 mm	130x130 mm
Length/round	333.34 mm	333.34 mm	333.34 mm
Wire diameter	1.35 mm	1.35 mm	1.35 mm
Device accuracy	±0.1 %	±0.1 %	±0.1 %
Adjustable speed	4 m/s	4 m/s	4 m/s
Telescopic spring force	4 - 16 N	4 - 16 N	4 - 16 N
Body material	aluminium	aluminium	aluminium
Protection class	IP64	IP64	IP64
Wire material	stainless steel	stainless steel	stainless steel
Weight (without encoder)	5 kg	6.2 kg	6.4 kg
Working and storage temperature	-30...+70 °C	-30...+70 °C	-30...+70 °C

# Draw Wire Mechanics EVD Series

## Dimensions (mm)

8...10m

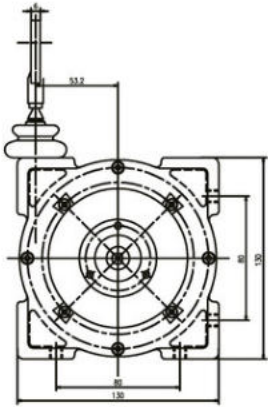
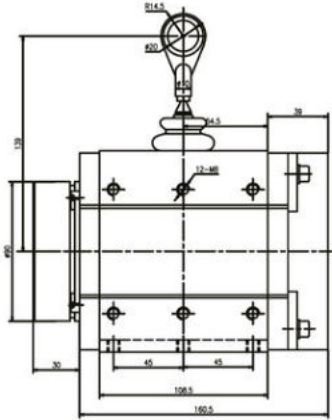

15m

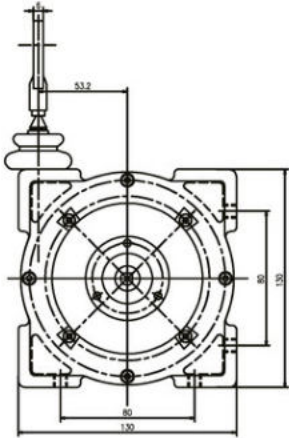
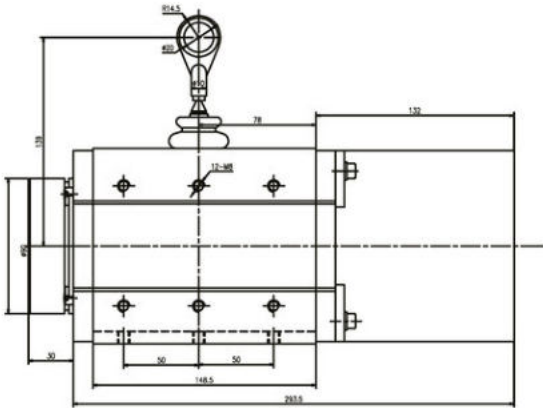

20m

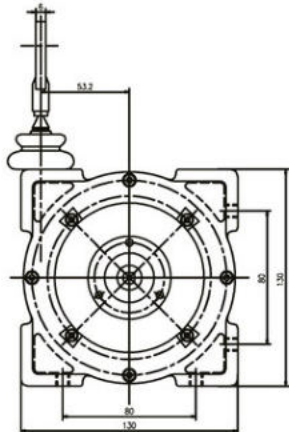
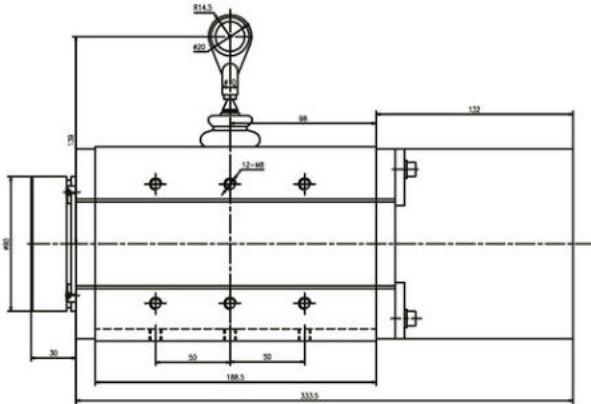

## Draw Wire Mechanics EVD Series

Order Code :

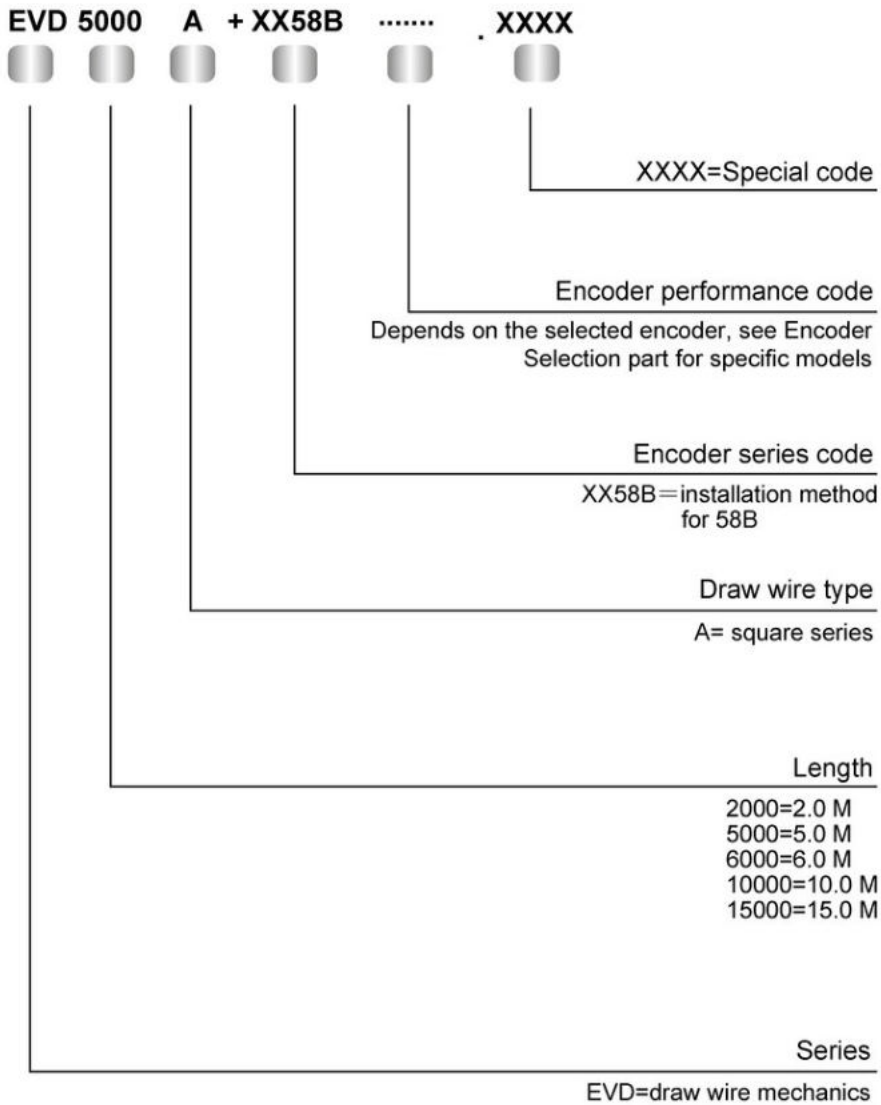

Attention: ELCO's installation accessories are recommended, rigid couplings mustn't be used among driving shaft, flange and encoder to protect shaft from overload.

ELCO Industrie Automation GmbH  
Benzstrasse 7  
71720 Oberstenfeld  
Deutschland  
E-Mail: [info@elco-automation.de](mailto:info@elco-automation.de)



[www.elco-automation.de](http://www.elco-automation.de)

ELCO (TIANJIN) ELECTRONICS CO., LTD.  
No. 12, 4th XEDA Branch Road  
Xiqing Economic Development Area  
Tianjin 300385, P. R. China  
E-Mail: [info@elco.cn](mailto:info@elco.cn)



[www.elco-holding.com.cn](http://www.elco-holding.com.cn)