

GERICKE GS CENTRIFUGAL SIFTING AND SIZE CONTROL

High efficiency, high capacity
Particle size separation

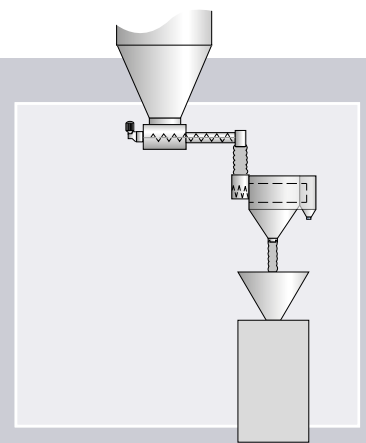

SIFTER APPLICATIONS

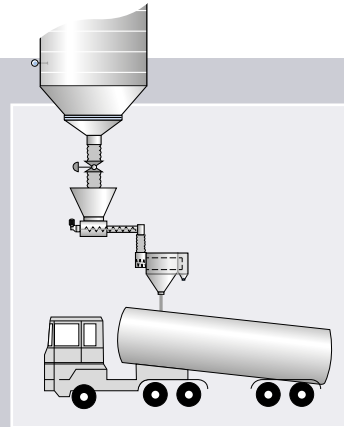
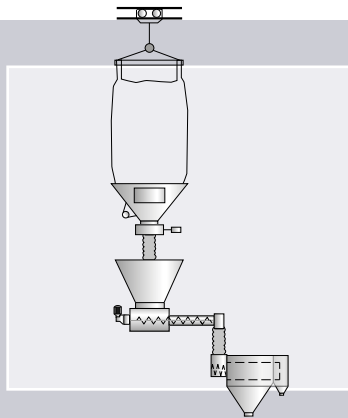
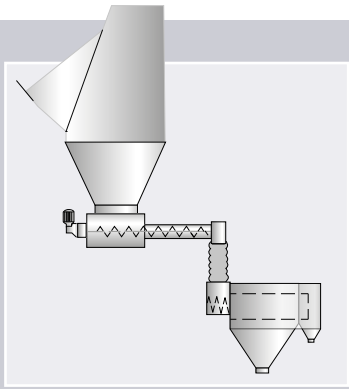

START OF A PROCESS

- Screening after a Sack-tip station
- Screening after an FIBC Big-Bag discharger
- Deagglomeration
- Silo discharge screening
- Tanker un-loading

END OF A PROCESS

- Final screening before bulk out-loading
- Final product screening before packing machines
- Calibration of bulk density
- Classification prior to downstream process

Applications

- Policing and scalping of Raw Materials after discharge from sacks or boxes
- Two part classification and separation
- De-dusting: removal of fine particles from main product mass
- Re-claiming materials after de-packing
- Final security screening before packing or bulk out-loading
- De-watering: separating solids and liquids
- Inline sifting in vacuum or positive pressure conveying lines

Gericke sifters are utilised to guarantee product quality within the processing of powdery products, granules, or fibre. Our ATEX certified sifters provide three main operations of the sifting processes:

1. Particle Separation; the separation of two different product fractions with varying particle size, typically within the range of 40µm to 5 mm.
2. Safety sifting; removal of foreign parts and tramp material prior to product entering the production process or to secure product quality before filling processes.
3. Conditioning; to separate foreign bodies and condition the bulk density of the product prior to entering production or immediately before packing.

IN-LINE SIFTER APPLICATIONS

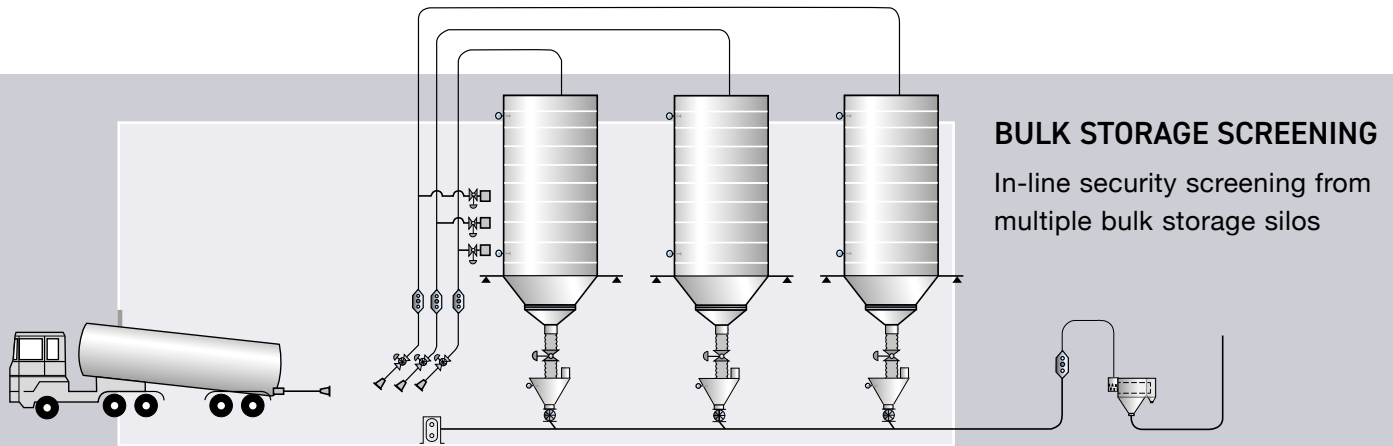

BULK STORAGE SCREENING

In-line security screening from multiple bulk storage silos

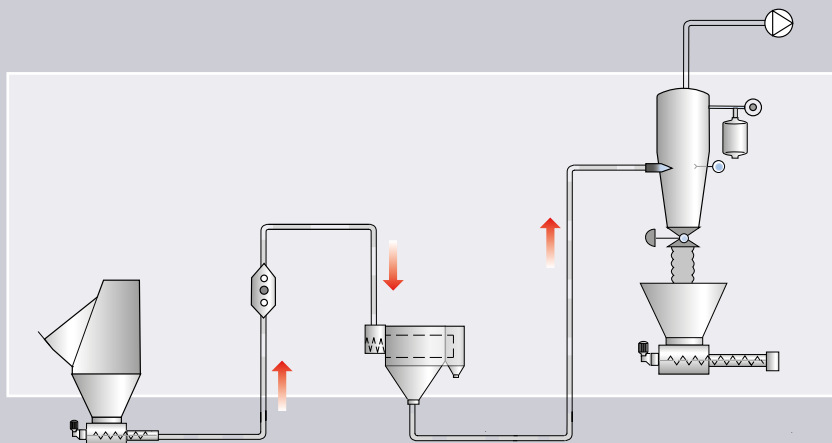

PNEUMATIC CONVEYING

In-line sifting in pneumatic conveying systems. Rated for both vacuum and blowing systems.

Advantages

- High capacity / high efficiency
- Robust and reliable construction
- 360 degree in-situ rotating screen inspection
- Quick change-over of screens without special tooling
- Ease of maintenance
- Pressure rated design for in-line applications
- Dust tight construction
- Low levels of vibration: no need for flexible connections to inlet or outlet

ATEX

Full ATEX type certification available for safe area, Zone 22 and 21 external and Zone 20 internal.

The full range of screens can be adapted for use within ATEX applications, including; HD Nylon, Polypropylene, Carbon Fibre, Perforated plate and Wedge Wire, taking into account risks such as propagating brush discharge.

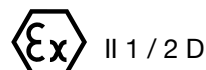



Gericke sifters have been designed and developed for the .optimisation of these sifting applications. The basic principles of centrifugal sifting provides high level performance and optimum separation with a minimal footprint.

The high throughput capability of sifters justifies them as the effective choice for bulk sifting requirements prior to the filling of silos from tankers.

Sifting capacities from; 2-3 kg/hr guaranteeing product quality of high value small batch operations, up to 120 te/hr, minimising the time-frame for filling of road tankers, a preferred method utilised throughout the milling industry and the production and processing of sugar and starch.

COMPETENCE IN YOUR APPLICATION



For more than 50 years Gericke has provided Centrifugal sifting solutions to the solids and powder handling industry, gaining unrivaled experience handling a multitude of materials in many applications, catering for a wide range of industries including; food, chemical, pet food, beverages, dairy processing; infant formula and pharmaceutical.

Our ability to supply complete turnkey systems ensures that Gericke can optimise the interfaces between the sifter and other essential process components which is a critical factor in ensuring a successful installation.

The Gericke range of centrifugal sifters is specifically designed to separate particles of different sizes into two distinct product streams. The rotation of paddles within a fixed screen is a time proven process and makes centrifugal sifters the most efficient equipment for high efficiency and high capacity product screening and classification.

Gericke sifters offer an economic solution for securing food safety, size control and gentle de-agglomeration.

FEATURES OF THE GERICKE GS CENTRIFUGAL SIFTER



Interlocked hinged door access

Time delay interlock ensures operator safety. Balanced hinged door for single hand operation and access.



360 degree basket and screen inspection

Basket and screen can be fully rotated within the casing, allowing ease of inspection and reduced maintenance timeframes.



Maximised access for set-up and maintenance

The new range of Gericke sifters provides excellent access for service and maintenance via large removable covers with a single captive fixing.

Maximise efficiency, reduce down-time and increase productivity

The process of centrifugal sifting remains mostly unchanged from the first machine concepts, whereby a paddle assembly rotating within a static hose is used to create a centrifugal force to push material against the sieve mesh and through pre-determined holes.

Whilst the concept is well-proven, the demands of modern processes are ever increasing and the new range of Gericke GS sifters has been specifically designed to remain one-step ahead of these demands.

The new range of sifting machine provides time-proven application technology, yet allows for rapid inspection, cleaning, change-over, repeatability, access and maintenance.



Positive basket location and screen positioning

Basket location points and robust fixing studs ensure the basket & screen assembly is returned to the optimum position every time.



Maximised access for cleaning

With both end and side doors open, basket and shaft removed, the GS sifters offer class leading access for dry cleaning and inspection.



Quick release shaft option

A quick release shaft is available for applications where regular shaft removal is necessary for frequent strip down and cleaning.

Basket design sets new standards for minimising clean down time and set-up

The sieve hose is arguably the most critical component of every sifting operation.

To perform effectively the sieve hose is tensioned on the basket and correctly positioned within the machine casing.

The evolved design of the Gericke sifter basket allows the sieve to be tensioned correctly without affecting the overall basket length.

Handles on the basket end ring provides ease of removal and replacement, and the orientation of the basket assembly is clearly identified on the end ring plate.

The location and securing of the basket is directly off the machine casing ensuring correct installation repeatability following clean down or change over.



PRINCIPLES OF SIFTING

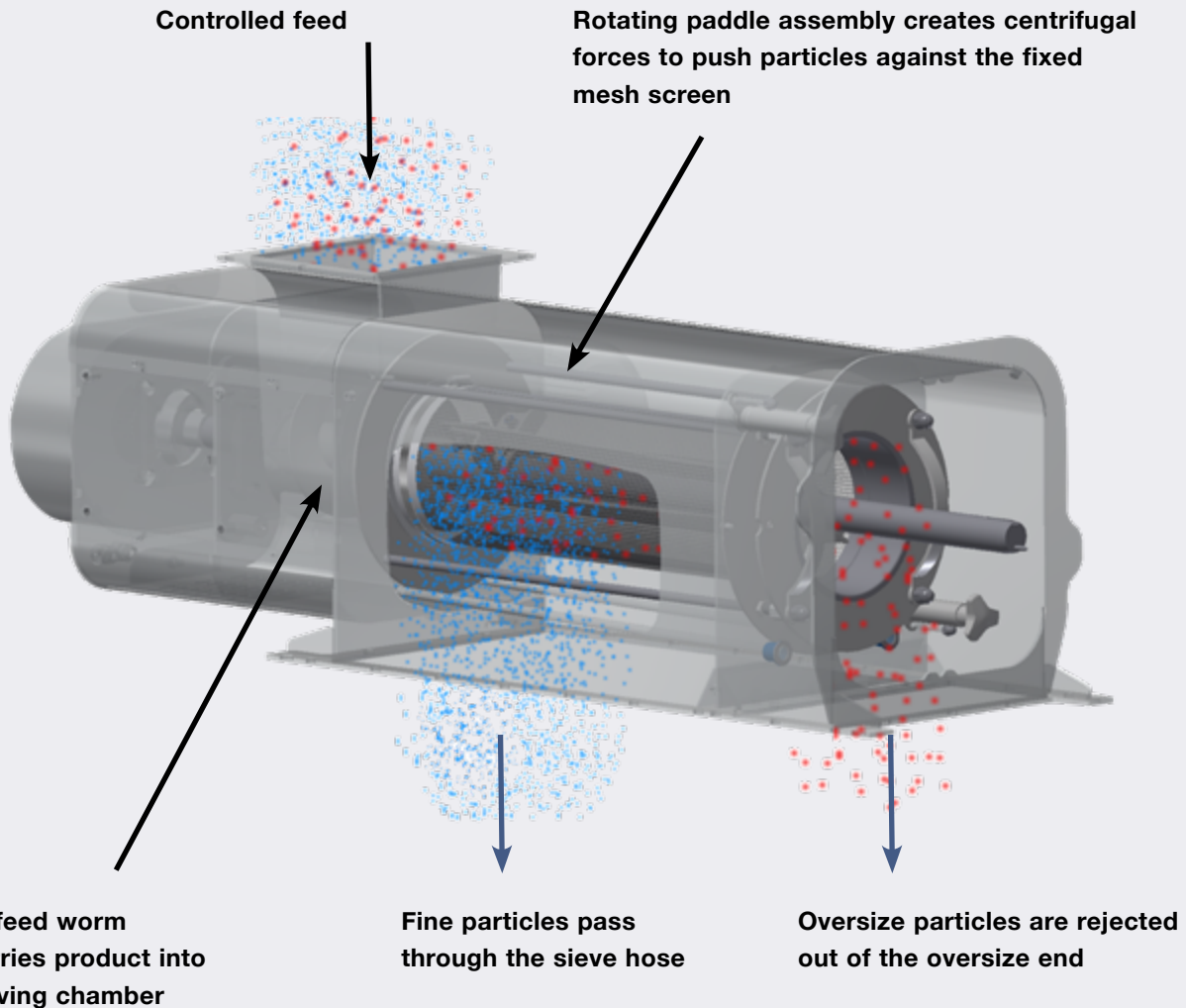

Centrifugal sifting is a process for separating bulk material into two streams of product.

- Centrifugal Sifters are designed for use with a controlled in-feed
- Gericke recommend fitting a level probe to the outlet hoppers
- Sifters are most efficient with an unrestricted air-flow through the machine
- Restricted end plates are available to improve efficiency and reduce over-tails
- Gericke will work with you to advise the optimum Sifter set-up to suit your application

Sifter capacities

Products	Capacity Range	Typical Mesh size
Flour	130 – 80000 kg/hr	400 - 6000 μ
Starch	300 – 20000 kg/hr	100 – 2000 μ
Spices	500 – 8000 kg/hr	600 – 3000 μ
Milk Powder	400 – 20000 kg/hr	100 – 3800 μ
Cosmetics	500 – 8000 kg/hr	630 – 1000 μ
PVC	130 – 8000 kg/hr	125 – 3000 μ
Detergent / Soap powder	1100 – 2700 kg/hr	500 – 1700 μ
Phosphates	1200 – 7000 kg/hr	125 – 4000 μ
Gypsum	1000 – 20000 kg/hr	200 – 500 μ
Sugar	100 – 9800 kg/hr	215 – 4000 μ

Figure shown are based on trials using GS722 sifter.

SIFTER RANGE

Model	GS4-722 / 1022	GS4-1130	GS4-1542	GS4-1542 Twin
A	1626	2054	2461	2461
B	455	680	800	1135
C	768	870	1038	1745
D	400	530	705	705
E	445	635	725	725
F (RAD)	511	638	759	759
G (Square)	266	336	486	486
H (RAD)	573	873	873	873
I	482	702	702	702
J	243	353	353	353
Q	-	-	-	700

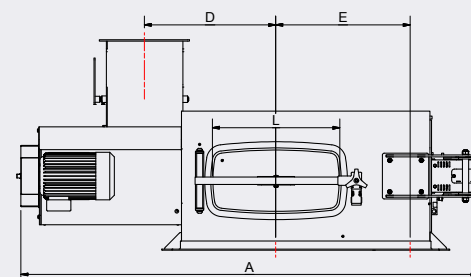
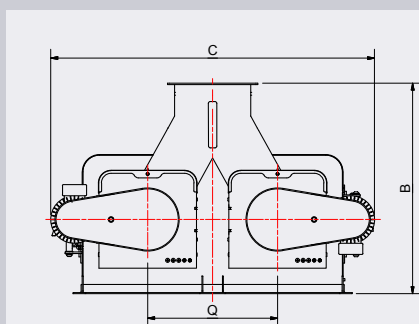
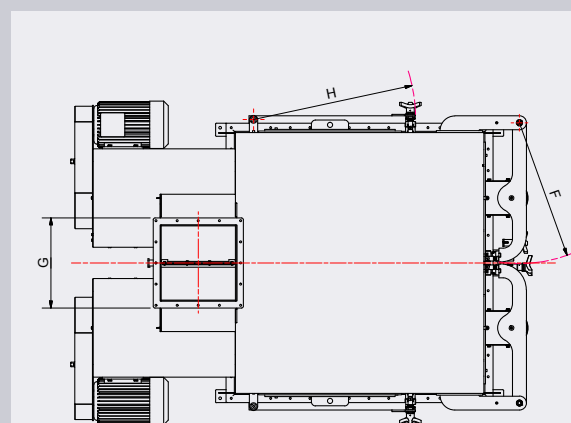
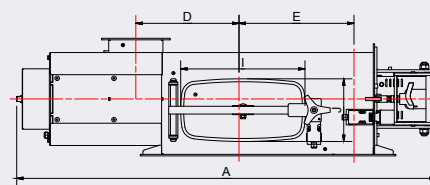
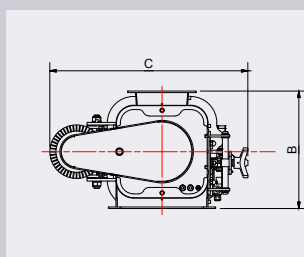
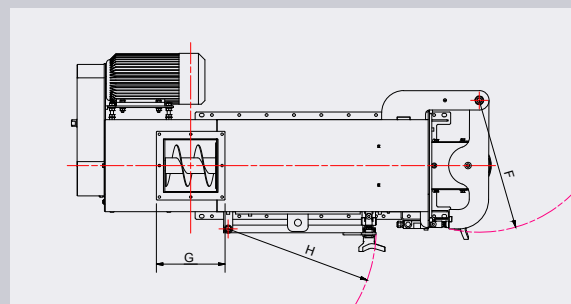



TEST CENTRE

Tests on an industrial scale reduce planning time and increase process safety!

Test centres in Switzerland, France, England, Brazil, USA and Singapore are available for customer tests under near-production conditions. The test centres are equipped with original machines. Experienced specialists design the test layout according to your wishes and perform the tests.

- Testing of machines and prototypes with original products
- Checking of performance ranges and accuracies
- Testing of the interaction of multiple machines
- Gaining of experience for product processing
- Sampling for laboratory tests and market response
- Customer training

SERVICE

Worldwide support for commissioning, maintenance and service.

We highly value punctual delivery, reliable assembly and thorough assembly monitoring. With well-planned commissioning and intensive on-site training we create the prerequisites for a smooth production start-up. Our service team and the global spare parts service combine to ensure long service life and high availability of systems with consistent product quality.

YOUR PARTNERS WORLD-WIDE

Switzerland

Gericke AG
T +41 44 871 36 36
gericke.ch@gerickegroup.com

Germany

Gericke GmbH
T +49 77 31 929 0
gericke.de@gerickegroup.com

France

Gericke SAS
T +33 1 39 98 29 29
gericke.fr@gerickegroup.com

United Kingdom

Gericke Ltd.
T +44 16 13 44 11 40
gericke.uk@gerickegroup.com

Netherlands

Gericke B.V.
T +31 33 25 42 100
gericke.nl@gerickegroup.com

USA

Gericke USA, Inc.
T +1 855 888 0088
gericke.us@gerickegroup.com

Brazil

Gericke Brasil Ltda.
T +55 11 2598 2669
gericke.br@gerickegroup.com

Singapore

Gericke Pte Ltd.
T +65 64 52 81 33
gericke.sg@gerickegroup.com

China

Gericke (Shanghai) Pte Ltd.
T +86 21 3306 3395
gericke.cn@gerickegroup.com

Indonesia

Gericke Indonesia (Rep. Office)
T +62 21 2958 6753
gericke.id@gerickegroup.com

Thailand

Gericke Thailand
T +66 2 325 0321-3
gericke.th@gerickegroup.com

Malaysia

Gericke Malaysia
T +60 16 253 1102
gericke.my@gerickegroup.com

For all other countries please contact Gericke AG in Switzerland.

GERICKEGROUP.COM

Gericke