



This page is intentionally left Blank for a printout

Printer Instructions: A4 size Layout, Landscape format, Double sided, Short edge binding



# 1. Introduction

Living walls bring many benefits to people and the environment; cleaning the air, improving health and well-being, enhancing biodiversity, using plants to soften and enrich previously hard, bare vertical surfaces. Biotecture has a proven track record for successfully designing, installing and maintaining hybrid hydroponic living walls both in the UK and other parts of the world. Biotecture is an innovative green infrastructure company with a suite of urban greening products for incorporating nature into the built environment.



## 2. Contents

	Page		Page
1. Introduction	3	9.8 Riser Covers, Copings and Window Surrounds	28
2. Contents	5	9.9 Testing	29
3. Company Information	6	9.10 Planting	30
4. Client References	7	9.11 Planting Design	31
5. Portfolio	8	9.12 Potential Planting Matrices	32
6. Benefits of living walls	14	9.13 Potential Statement Plants	33
6.1 Summary	14	9.14 Production	34
6.2 Biodiversity	15	9.15 Living Walls that Last	35
6.3 Air Quality	16	10. Maintenance	36
6.4 Biophilia	17	11. Contacts	40
7. Sustainability	18		
7.1 Product Sustainability	19		
8. Why Hydroponics?	22		
9. Specification	24		
9.1 General Description	24		
9.2 Support Structure	24		
9.3 Living Wall System	24		
9.4 Irrigation	26		
9.5 Fertigation	28		
9.6 Drainage	28		
9.7 Services	28		

### 3. Company Information

Biotecture designs, supplies, installs and maintains green infrastructure. We are an innovative UK based company managing projects across the country as well as mainland Europe, North America and the Middle East.

The company was established in 2007 by Richard Sabin, a sustainable building professional and Mark Laurence, a landscapes designer. Their goal was to design a new living wall system that would meet the growing demand for a genuinely sustainable option for vertical green infrastructure.

Biotecture developed a unique modular hybrid hydroponic system which is now patented. Launched at Ecobuild in 2008, Biotecture's living wall system won the annual prize for sustainable innovation. Good water management combined with remote sensing technology was the key driver of the initial development and continues to be so today. This efficiency enables us to work with confidence in all climates, from Chicago to Dubai.

The Biotecture horticultural team works from our own nursery in West Sussex where we have over 3,000m<sup>2</sup> of dedicated vertical growing space. The plants are nurtured through their early growth stage in our own greenhouses which allows for precision growing, robust root development and installation ready greening.

Biotecture is well recognised as the market leader for vertical green infrastructure. We have worked on a number of the most iconic projects around the world including the Apple Store in San Francisco, 20 Fenchurch Street in London and the Burj Khalifa Pond Island in Dubai

We are based in Chichester, West Sussex where our nursery is also situated. Biotecture has in house designers and project managers and can provide a fully managed green infrastructure service from concept right through to on-going maintenance. Our vision is to transform urban architecture for the wellbeing of people and the planet.



Fosse Park, Leicester

## 4. Client References



1. New Street Square, London      Installed 2011

“We recommend Biotecture because of the importance we place on selecting a supplier who has the expertise and commitment to design, install and maintain a successful large scale green wall”

Neil Pennell, Director of Sustainability

Land Securities

Reference Date: May 2015



2. MTV, Camden, London      Installed 2016

“The green wall looks really good, not only catching the eye of or staff but also, which is very important, the eyes of thousands of tourists and residents of Camden....Please thank the maintenance team”

Dave Bennett, Director - Planning and Design / Office Services

Viacom International Media Networks

Reference Date: April 2018



3. Warner Stand, Lords Cricket Ground, London      Installed 2017

“Biotecture cultivated six feature living walls at Lords, working on the Warner Stand. On a project with complex logistics and co-ordination, their flexibility was a pleasure to deal with. The end result is a delighted client as well as living walls which magnify the architectural intent”

Andy Lee

Site Manager, BAM Construction Limited

Reference Date: March 2017

5. Portfolio



Regal House, Covent Garden, London



Ashford Designer Outlet, Kent



Buckingham Gate, London



Bell Court, Stratford-upon-Avon



Court number 1, Wimbledon

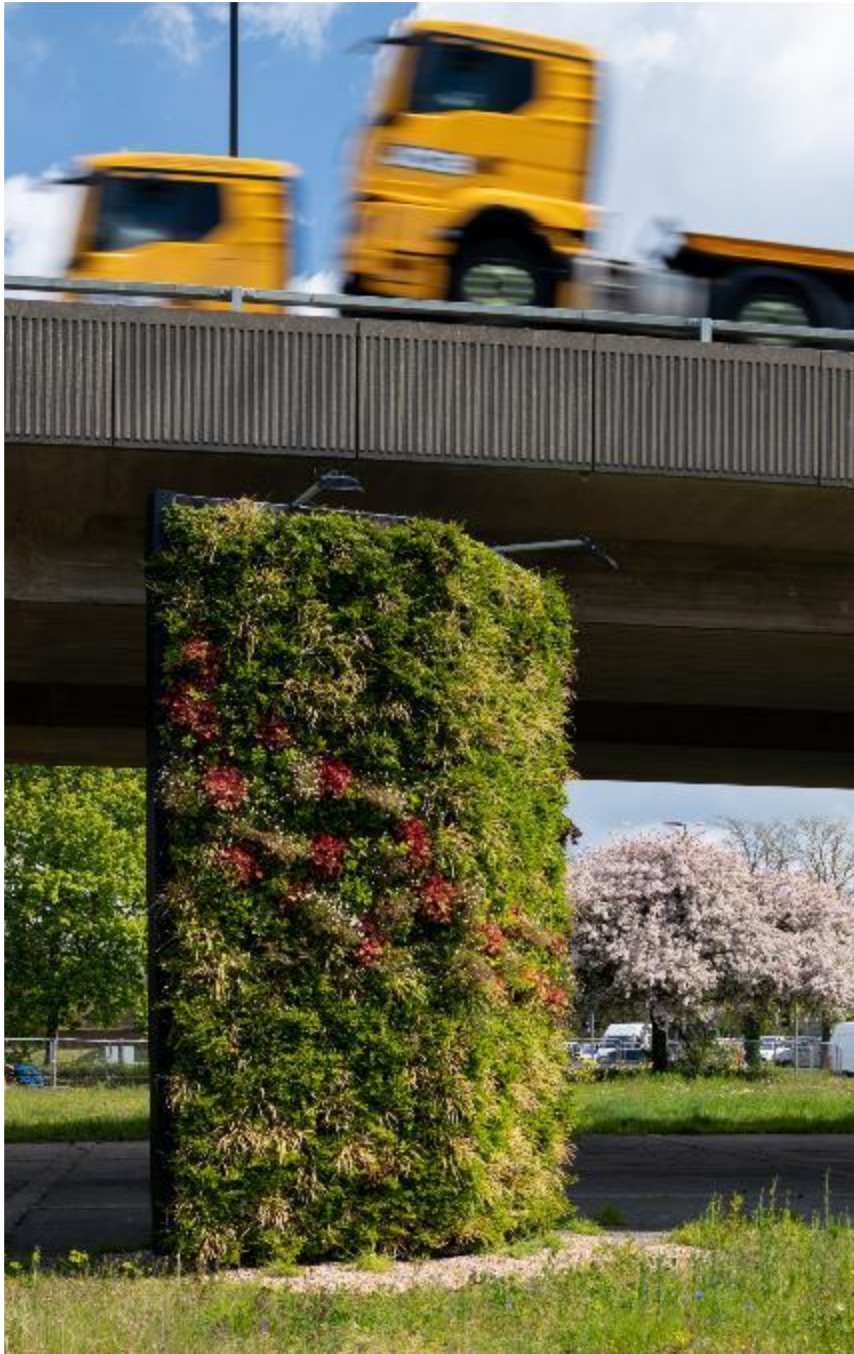

Millbrook Roundabout, Southampton

## 6. Benefits of Living Walls

### 6.1 Summary

Air Quality, Biophilia Acoustic Benefits, Biodiversity, Fauna & Flora

Living walls can act as green corridors through cities, creating a network of green spaces that enable wildlife to survive and thrive in the urban environment (Ignatieva, et al., 2011). The plants then attract wildlife, such as bees, butterflies and invertebrates. In her book *Biodiversity for Low and Zero Carbon Buildings* (2010), Carol Williams outlines the benefits to the urban bird population: “The array of insects and the seeds produced by the flowering plants all provide good feeding opportunities to a range of birds, from common garden birds, such as greenfinch, blackbirds and wrens, to goldfinch, linnets and even the rare black redstarts in certain parts of the country”. In addition to the potential food sources that a vertical or roof garden produces, the use of habitat boxes coupled with carefully chosen plant species, can create fantastic roosting/nesting places for birds as well as hibernation of invertebrates.





## 6.2 Biodiversity

Urban reconciliation is when human habitats can be modified to support a larger number of species without compromising land use. Living walls are the perfect example of how this can be done, if the walls are adapted to address specific functions missing in urban environments, such as wildlife habitats (Francis and Lorimer, 2011). This can also help to fulfil local Biodiversity Action Plans.

### Flora

The plants themselves also add to the biodiversity. Within the planting design, species have been selected that are of ecological value to pollinating insects.

### Fauna

Living walls can act as green corridors through cities, creating a network of green spaces that enable wildlife to survive and thrive in the urban environment

### 6.3 Air Quality

Outdoor pollution causes 35,000-50,000 premature deaths in the UK per annum (Pugh, et al., 2012) and is considered to be a major contributory factor for both cardiovascular disease and existing asthma (Environmental Audit Committee, 2012). Estimates suggest that a reduction of 1 µg/m<sup>3</sup> in the annual average population weighted concentration of fine particulates would result in a saving of approximately four million life -years over the next 106 years. However, plants can help offer a solution as:

During photosynthesis, plants absorb CO<sub>2</sub> and other gases, such as SO<sub>2</sub> and NO<sub>2</sub>, ozone and airborne ammonia through the stomatal pores in their leaves; They also intercept particulate matter (PM) and aerosols, and retain them on the leaf surface

#### Living walls as PM sinks

It is widely accepted that placing vegetation within urban environments has a significant affect on the air quality (Sinha and Singh, 2010), acting as sinks to reduce the concentration of PM in the local atmosphere—as demonstrated in the 2011 study of the living wall on Edgware Road Tube Station

The particulates are deposited onto plants when air currents bring them into contact with the surface of the plant leaves (Smith, 2011). The vegetation then filters these particulates, which would otherwise have been directly inhaled or eventually entered nearby waterways.

#### Choosing the right plants

Studies, including the 2011 study on the Biotechure wall at Edgware Road have found that plants with 'rougher', more textured leaves are more effective PM sinks, as this extends the surface area of the leaf, increasing the chances of PM being deposited (Smith, 2011). This directly impacts the plant choice for living walls, creating walls that will help ameliorate local air pollution. The selection process for the plant species within the Regal House living wall was based on this information (Refer to plants drawing).

#### Outdoor Air Quality

Textured leaves are more effective PM sinks, as this extends the surface area of the leaf, increasing the chances of PM being deposited (Smith, 2011). This directly impacts the plant choice for living walls, creating walls that will help ameliorate local air pollution. The selection process for the plant species within the Regal House living wall was based on this information (Refer to plants drawing).

#### Indoor Air Quality

Plants remove significant quantities of VOCs from the air

Plants reduce CO<sub>2</sub> levels by 10 to 25%





## 6.4 Biophilia

Edward Wilson used the term biophilia in 1984 to describe:

“the idea that humans possess a biological inclination to affiliate with natural systems instrumental to their health”

( Wilson, 1984 )

He went on to suggest that “the mere insertion of plants into the built environment can enhance comfort, satisfaction, wellbeing and performance” (Kellert, et al., 2008).

Currently, there is comprehensive scientific evidence to support Wilson’s idea; suggesting that when humans are surrounded by plants and nature their mood is improved, they are overall less stressed and in general their wellbeing is improved.

### An appreciation for nature

Being surrounded by a more natural environment also helps us to connect with nature and reinforces the values of respect and care for the environment (Heerwagen, 2009). This is particularly important in cities where only 30% of the area is greened, compared to 75-95% in outer suburbs (Johnston and Newton, 2004). Living walls offer the opportunity to closely interact with nature in these densely populated urban areas. Kellert, et al., 2008, made the observation that “buildings with green facades...often provoke interest and satisfaction” and that “some of our most successful buildings and landscapes foster an aesthetic appreciation for natural processes and form.”

### The calming effect of plants

Moreover, it has been suggested that whilst our daily activities require our direct focus and attention, which throughout the day can cause mental fatigue, paying attention to nature is almost effortless, providing the human mind with a much needed respite (Kaplan, 1995). Therefore, nature plays a role in reducing stress. This means the living wall at Nova Victoria can directly impact on the pedestrians, visitors and occupants of the building, providing a calming effect, reducing stress levels and giving psychological uplift to those that view the wall.

## 7. Sustainability

Sustainability is at the core of what we do at Biotecture. For more on our ethos please have a look at the What Motivates Us page of our website: <https://www.biotecture.uk.com/about-us/what-motivates-us/>



## 7.1 Product sustainability

### Embodied carbon

The shells of our Biotile Living Wall System are manufactured from 100% post-consumer waste recycled plastic and as such has both a very low embodied carbon and saves materials from going to landfill. Research shows that the emissions reductions from eliminating the need for new plastic significantly outweigh the emissions that come from processing the scrap. As of 2018 90.5% of plastic went un-recycled worldwide. We want to be part of changing this.

The Biotile shells are manufactured from recycled polypropylene which is estimated to have an embodied energy of approx 40 MJ/kg compared to virgin polypropylene which is estimated to have an embodied energy of approx 80 MJ/kg. So there is a saving of approx 50% of embodied energy just in the manufacture and there is the saving on landfill.

Our hydroponic growing media is manufactured by Grodan. It comes from natural materials and is dimensionally stable and chemically inert which means it does not degrade and will last decades. If a project is completed then the Grodan is perfect for use as brick aggregate

It is also important to note that the Biotile living wall system, when incorporated into new builds, is designed specifically as the rainscreen element of the building. As such it is a replacement material for whatever else might have been on the outside of the building and therefore is a replacement cost rather than an additional cost. From an embodied carbon point of view the saving of being a replacement material should also be considered.

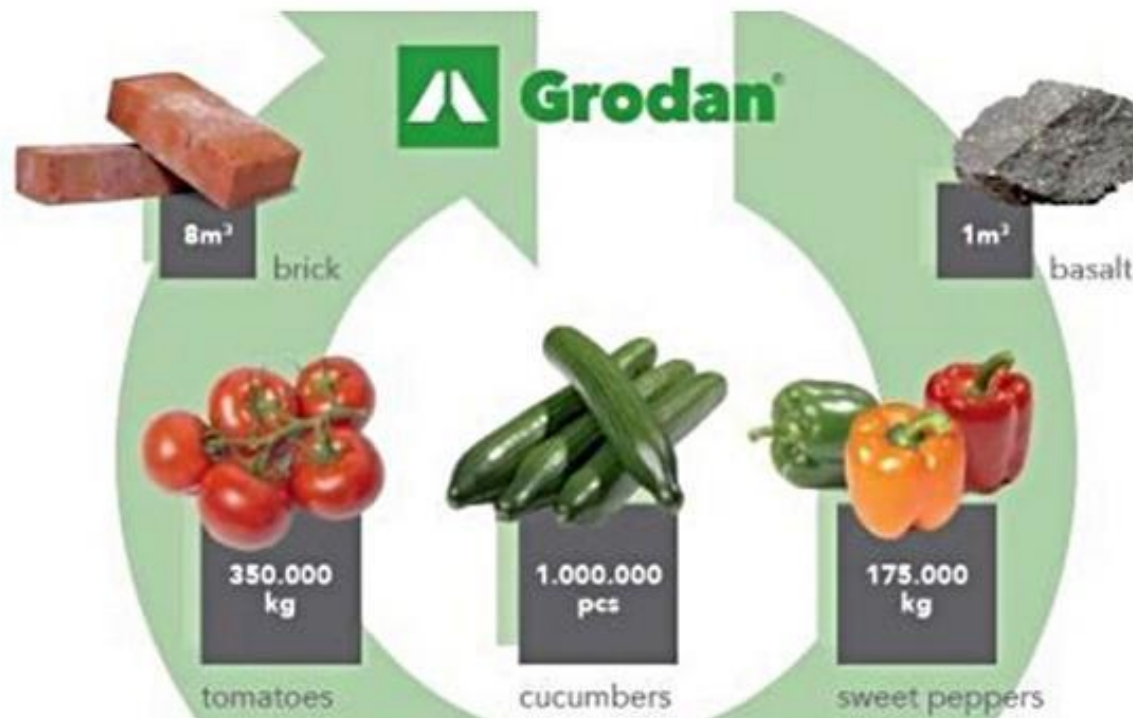

**Table 3-9. Savings for Recycled Resins Compared to Virgin Resins**

	Recycled PET		Recycled HDPE		Recycled PP	
	Recycled % of Virgin	Recycled Resin % Reduction from Virgin	Recycled % of Virgin	Recycled Resin % Reduction from Virgin	Recycled % of Virgin	Recycled Resin % Reduction from Virgin
<b>CUT-OFF</b>						
Total Energy	21%	79%	12%	88%	12%	88%
Water Consumption	104%	-4%	41%	59%	54%	46%
Solid Waste*	42%	58%	101%	-1%	77%	23%
Global Warming	33%	67%	29%	71%	29%	71%
Acidification	30%	70%	53%	47%	42%	58%
Eutrophication	54%	46%	102%	-2%	57%	43%
Smog	25%	75%	63%	37%	50%	50%
<b>OPEN LOOP</b>						
Total Energy	61%	39%	56%	44%	56%	44%
Water Consumption	102%	-2%	71%	29%	77%	23%
Solid Waste*	71%	29%	100%	0%	88%	12%
Global Warming	66%	34%	65%	35%	64%	36%
Acidification	65%	35%	77%	23%	71%	29%
Eutrophication	77%	23%	101%	-1%	79%	21%
Smog	63%	37%	82%	18%	75%	25%

This table comes from the Science Paper, Life Cycle Impacts for Post-Consumer recycled resins: PET, HDPE, PP by the Association of Plastic Recyclers, December 2018.

\*Solid waste excluding contaminants removed from incoming material. These contaminants are not caused by recycling and would have been disposed as waste regardless of whether postconsumer plastic recycling takes place.

Manufacturing

The recycled Biotile shells are manufactured in the UK. The hydroponic growing medium is manufactured in the EU by Grodan who have been awarded the prestigious EU EcoLabel for sustainability.



EU Ecolabel: NL/048/001

Warrantee

10 years subject to correct use, however it is worth noting that the living wall at Edgware road underground station (the one on the front cover of this document) is 10 years old this year and still going strong.

Water Usage

The hydroponic growing medium is perfect for water retention and we are irrigating directly at the rootzone so losses are minimal. The Biotile system benefits from our rear drainage technology meaning that we can be precise about water volumes and water usage. As an annual average water usage is well below 1 litre per m2 per day

## Electricity Consumption

Pumps are rated at 0.8kW – 1kW. Electricity consumption is dependent on the size of the green wall but the pumps are only operating for between 1 and 12 minutes per day per section of green wall. For a 100m<sup>2</sup> for example we calculated the annual energy use to be £5—£10.

As well as the financial cost it is also worth considering the Greenhouse Gas impact for living walls in operation:

## Greenhouse gas example calculation:

We have conservatively estimated the greenhouse gas impact for a 100m<sup>2</sup> outdoor wall measured in terms of carbon dioxide equivalent (CO<sub>2</sub>e) emissions. This relates to an actual installation and the associated pumps & controller. Conversion of water and energy use to CO<sub>2</sub>e are done using Defra provided conversion factors:

- Water –We expect the usage to be around 100 litres per day (1L per m<sup>2</sup> per day as an annual average) depending on the heating and ventilation in the space. This equates to 36,500L per year. Defra conversion factor for fresh water supply in the UK is 344 kg CO<sub>2</sub>e per million litres of water. The associated emissions are therefore 0.013 tonnes of CO<sub>2</sub>e / year.
- Electricity use – the pump, Heron controller and lighting specifications and assumptions for this wall are as follows (Defra conversion factor for UK electricity per kWh is 0.2556kg CO<sub>2</sub>e):

The 0.8kW pump runs for 9 mins/day as an average, equating to 0.011 tonnes CO<sub>2</sub>e/year.

The 230W Heron controller operates continually, generating 0.51 tonnes CO<sub>2</sub>e / year.

In total, this is around 0.53 tonnes of CO<sub>2</sub>e per year. For comparison this is around ONE TENTH of the UK GHG emissions per person in the UK\*

\*UK GHG emissions per person in 2017 (latest figures available) were estimated as 7.65 tCO<sub>2</sub>e per year) (Committee on Climate Change, 2019).

Note: we are in the process of establishing the Greenhouse Gas impact of our maintenance services but it seems clear that the environmental benefits that green walls provide far outweigh the environmental cost of operating and managing them.

## Plants

Our living walls are always grown with peat free growing medium.

All plug plants are sourced from suppliers with full plant passport visibility in Europe, many in the UK. The plug plants are then grown on in our own nursery in West Sussex

Biotile can be used to grow a wide variety of plants (see pages 30 to 33 of this document for more information about planting)

For all living walls that Biotecture maintain we performance guarantee that 95% of plants in the living wall will be alive at all times.

## 8. Why Hydroponics?

Hydroponics, the cultivation of plants using a nutrient solution in the place of soil, has rapidly become the preferred growing method in horticulture, due largely to its efficiency and predictability. Soil, although natural, is unable to sustain healthy plants in a vertical landscape such as a living wall. Here's why:

### 1. How Plants Grow in Soil

In naturally sustainable (horizontal) landscapes water transfers nutrient solutes around and soil particles attract and hold these through ionic bonding. The humus content of soil helps buffer pH, and is the end result of the breakdown of compost into humic acids and humins.

The soil is also layered with micro-organisms and mycorrhizae each performing specific functions, all of which add up to an incredibly complex web of self-regulatory systems, which create a stable environment for life. Gravity plays a huge part in the stability of these systems; holding it all together and ensuring the necessary inputs of rainwater and fresh material in the way of falling dead and decaying matter.

*It is simply not possible to replicate this naturally occurring environment in a vertical plane.*

### 2. Vertically Challenged Soil

When compost or soil is stacked vertically there are three fundamental issues:

- **Physical Restraint**—The first problem is physical restraint - preventing displacement from erosion and settlement. In windy conditions, this can be exacerbated with a winnowing effect.
- **Exhaustion Of Nutrients**—Unlike a sustainable horizontal landscape there are no inputs available to replenish the soil so, as for hydroponics, nutrients are added through the irrigation system. However, unlike hydroponics, soil will begin to 'lock on' to these nutrients.
- **Excess Mineral Salts**—This 'lock on' to nutrients leads to a build-up of excess mineral salts (via un-buffered ionic bonding). In turn and over time these excess mineral salts begin to literally starve the plants of nutrients.

### 3. How Plants Grow In Hydroponics

Hydroponics by-pass all of soil's complexity, whilst avoiding the problems of using compost as the growing medium. In soil, a plant might expend 60% of its energy in searching for food, whilst hydroponic plants have everything delivered to them.

Hydroponic mediums have a zero-cation exchange and nutrients are supplied in a precise and controlled manner. This means that far less water is required as an input to a hydroponic system.





#### 4. Grodan® — The Ultimate Growing Medium For Living Walls

At Biotecture we carried out extensive research and trialling, working with several horticultural companies, before we selected Grodan® in 2008 as our growing media partners for our patented living wall panel system. It is the perfect material for vertical growing.

Grodan® are part of the Rockwool Group and their mission statement is “to supply innovative and sustainable stone wool growing media solutions to the professional horticultural sector based on precision growing principles”. As a professional horticultural company ourselves we understand that the vitality and longevity of our living walls depends on precision growing principles.

Grodan® has been awarded a European Ecolabel for sustainability and as a material it is:

- Dimensionally Stable—We use a dense grade of Grodan® that was developed for roof gardens in Scandinavia. Tests of original installations show no sign of structural decay after more than 20 years.
- Chemically Inert—Grodan® has a zero-cation exchange, which means no ionic bonding occurs with the nutrients, so there is no chance of nutrient lock or a build-up of salinity.
- Supremely Water Efficient—The Grodan® that we use creates a water-retentive sponge which starts as 95% air and will hold up to 80% moisture before the material starts to drain. Even when fully saturated the spun fibres ensure that 15% of the volume is air space to not drown the roots.

#### 5. Grodan® v. Soil For Living Walls

The above three factors mean that Grodan® is the most robust, resilient and precise growing medium available for use in living walls. It will:

- Withstand wind better than soil
- Outlast soil by decades
- Continually offer a more predictable root zone for the plants than soil
- Not lock-on to nutrients with age thereby offering a full suite of nutrients to the plants throughout their life unlike soil
- Grow longer lasting more resilient plants than if grown in soil
- Require far less water than soil throughout the year
- Demonstrate far greater resilience than soil in an outage because of its incredible (and predictable) water retentive quality – *because of this our living walls will last more than 2 weeks without irrigation if necessary*

*Simply put: if the goal is to achieve a long lasting, resilient, low water use living wall with healthy plants then there are no valid reasons that we can think of for choosing soil over Grodan® as the growing medium in such a technically, horticulturally and hydraulically challenging environment.*

# 9. Specification

## 9.1. General description

Living vertical artificially irrigated and fertigated ‘backless’ vegetated cladding panels complete with inorganic growing medium fixed through a void former and waterproof backing board to cladding rails. Saturated weight of panels, growing medium and plants = max 65kgs per m2

## 9.2 Support structure

Support structure to provide maximum 600mm fixing positions with vertical support rails and minimum 100mm width for fixing

Support structure will vary from project to project but will be typically a Hilti helping hand system, bespoke galvanised steel box sections or timber battens

## 9.3 Living wall system

### 1. Waterproof backing board

Durable water-resistant board 12mm thickness – Versapanel Eco sheet or similar fixed to the support structure

### 2. Aluminium rail

‘T’ profile rail carrier system to carry the BioWall panels (vegetated cladding panels)

### 3. BioTile® panel (vegetated cladding panels)

Injection moulded panel box to support the growing medium, formed using black colour general purpose polypropylene compound manufactured from recycled polymer

Standard panel module dimension 600mm wide x 450mm

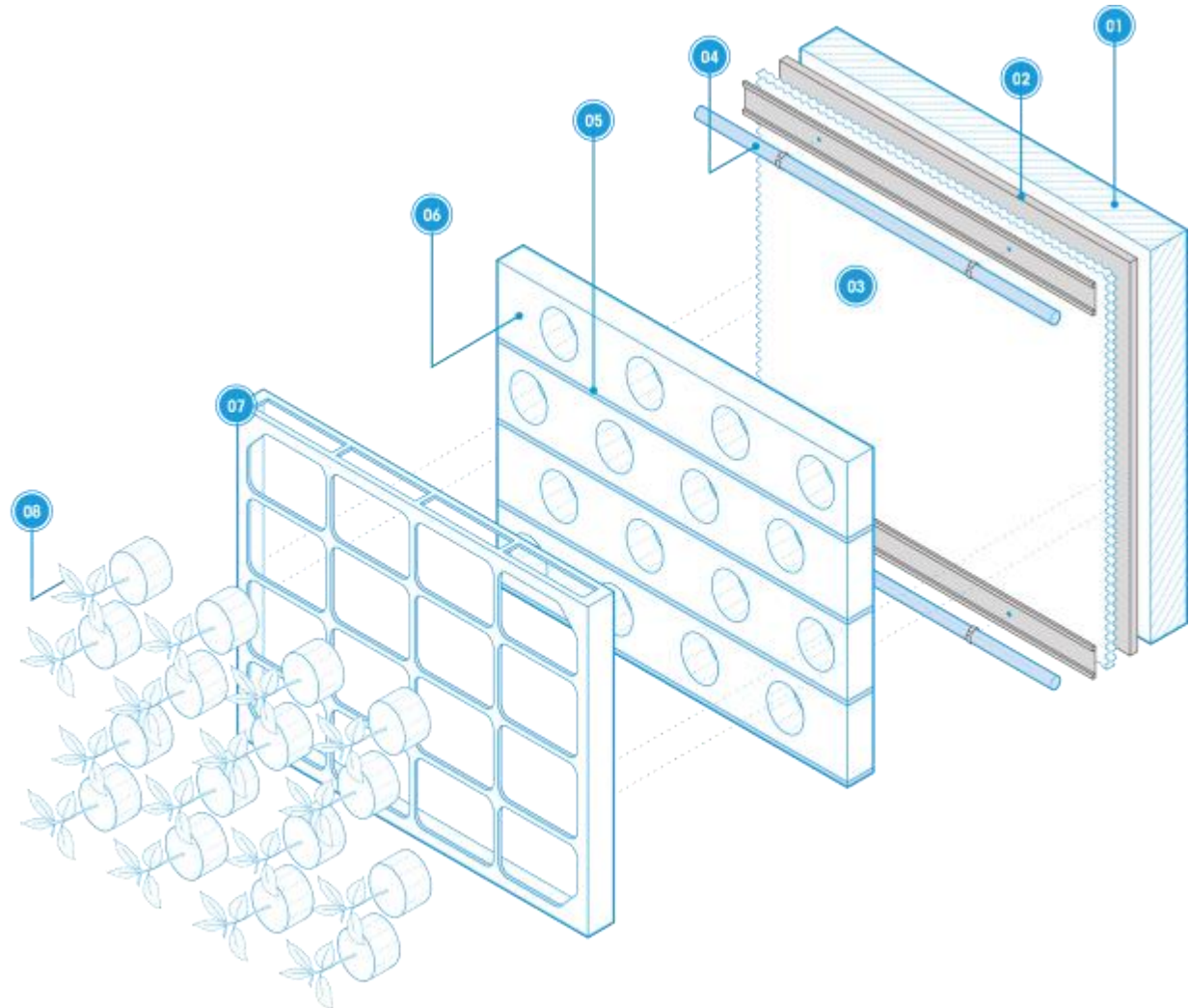

01. Support system

02. Waterproof backing board

03. Rear drainage layer

04. Aluminium rails & dripline

05. Capillary breaks

06. Growing medium

07. Panel box

08. Plants



#### 4. Growing medium

Inorganic, chemically inert and dimensionally stable growing medium with a nominal dry density of 16.8kg/m<sup>3</sup>. Material 'stonewool' – high alumina, low silica wool product reference Grodan PP 100/100 or similar approved

Within a standard panel - 4no. strips of Grodan with capillary break between each section

Each tile to have 16no. planting holes (4no. per Grodan strip) with 50mm diameter to the planting hole Capillary breaks - geocomposite drainage layer formed using extruded high-density polyethylene (HDPE) net drainage core with nonwoven polypropylene (PP) geotextile filter/ separator bonded to one side and an extruded (PE/EVA) geomembrane bonded to the other

#### 5. Rear drainage layer (void former)

Geocomposite drainage layer comprising a high-performance single cusped HDPE (High density polyethylene) core with a geotextile filter thermally bonded to one side to provide a drainage layer to the rear of the vegetated planted panels and a waterproof layer in front of the backing board

#### 6. Dripline

Polypropylene round dripline, 16mm diameter, with flat pressure compensating drippers (4no. drippers per standard Biotile) giving dripper flow rate of not less than 1.6 l/h. Dripline fixed to the carrier rails using proprietary injection moulded polypropylene clips

Rigid PVC extrusion cover strip to provide improved visual appearance and solar protection to reduce solar gain to dripline, clipped to irrigation lines using proprietary clips

## 9.4 Irrigation

### 1. General description

A suitably sized WRAS approved break tank to hold 24 hours of irrigation water supply. Pumping is to be via a reliable pump set capable of delivering the correct pressure at all drip locations. Water is to be distributed from the pump through zoned solenoid valves via a ring main and header pipes with control being via a remote sensing computer controller. System is to include a fail-safe pump start relay

Irrigation water is to be precisely applied via irrigation driplines of no less than 16mm diameter. The drippers are to be in-line, self-flushing and self-cleaning pressure compensated drippers each operating at minimum of 1.6 litres per hour. The system will include the ability for each dripline to be easily flushed on a regular basis

Biotope irrigation to be located in weathertight plant enclosure - see 'services' section for the services requirements. Plant enclosure sizes will vary depending on the size of the living wall and the irrigation design

### 2. Break tank

WRAS approved high density polyethylene break tank with integral submersible pump.

### 3. Irrigation fittings

Wall/array fittings all barbed, Couplers, elbows and T pieces with non-return valves if required, to suit the installation

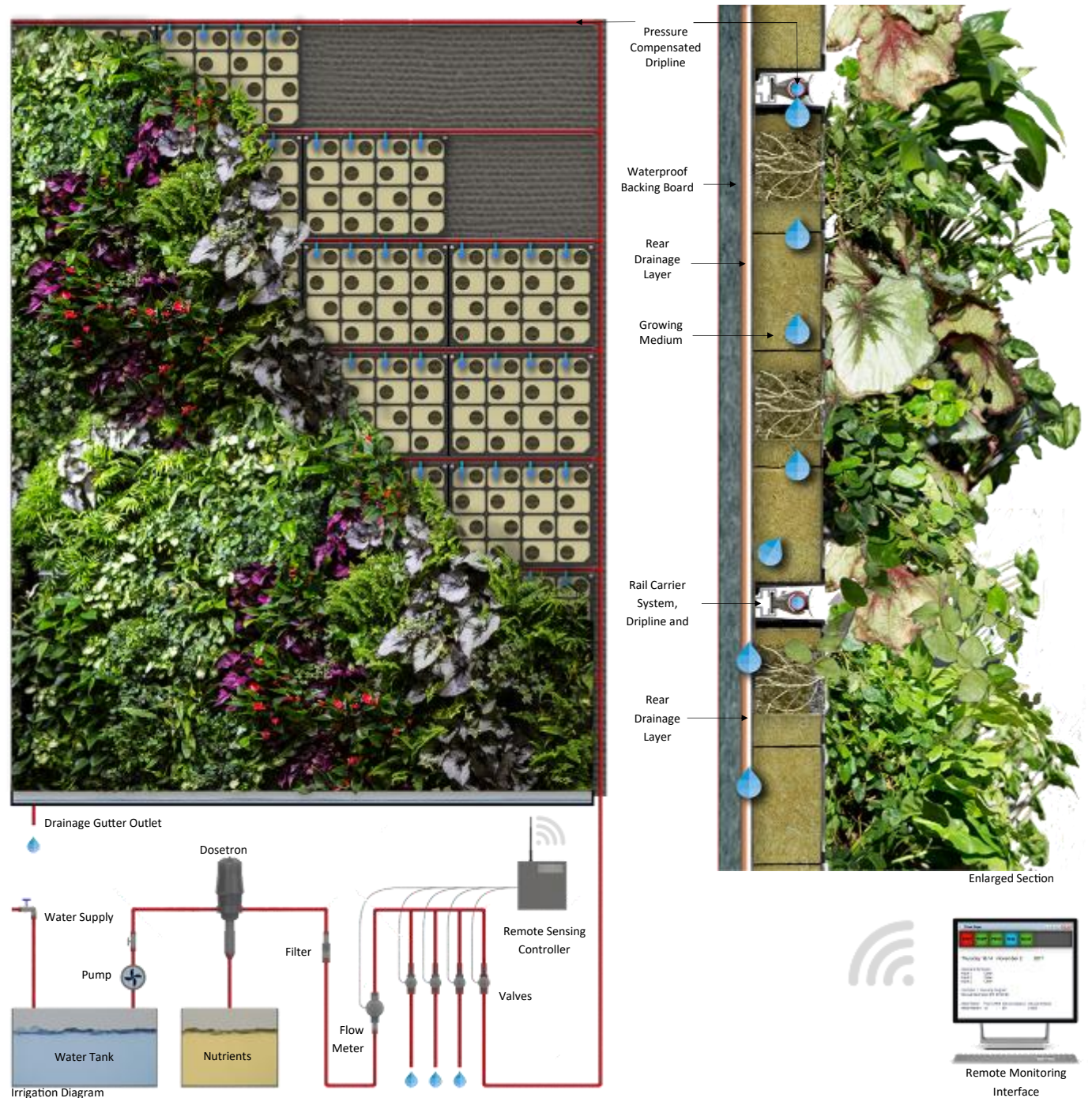



Typical Irrigation Rig for living wall over 100m2



Valve Arrangement—Fenchurch Street

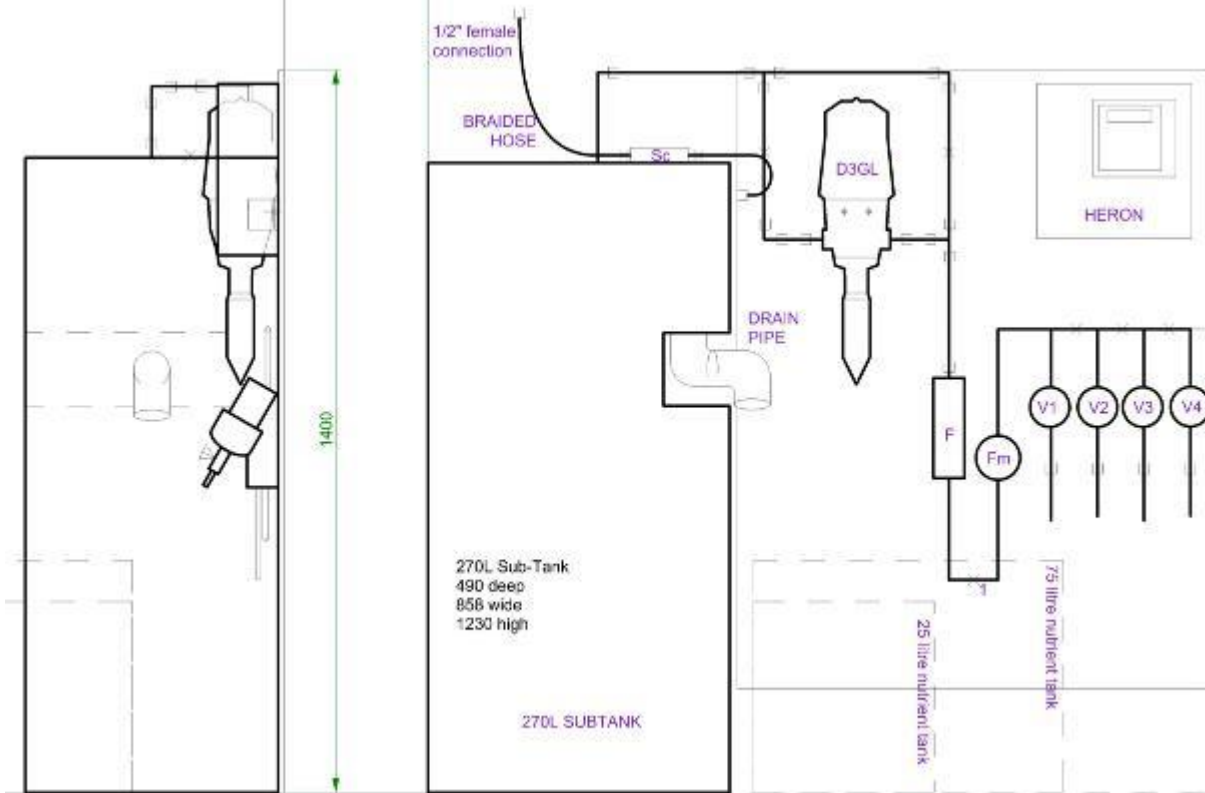

Typical Irrigation Rig for living wall over 100m2

#### 4. Water feed pipework and irrigation pipework

20/25mm LDPE water feed pipe (pipe diameter varies according to the distance between the plant and the living wall)

Irrigation pipework – 20mm HDPE hose with barbed fittings

#### 5. Irrigation controls

Multi wire controller to operate the solenoid valves. Manufacturer: Heron or similar approved

The controller will be programmed with flow-rate parameters for each zone and will be set to monitor the flow-rate at prescribed intervals (usually 30 seconds). It will also be set with a deviation percentage. When the controller monitors a flow-rate that deviates from the expected flow rate by more than the input deviation percentage it responds by, firstly shutting off the pump and secondly sending an alert by email

GPRS signal or LAN connection required in order for the controller to communicate with remotely with the Biotecture server

## 9.5 Fertigation

Nutrients are to be added to the water flow by means of a Dosatron or similar impeller device. Essential macro and micro nutrients added at a rate of between 0.2% and 0.5% by volume. The nutrient mix is to be as prescribed by Biotecture. Nutrients are to be stored in a separate tank and fully integrated with the irrigation system

## 9.6 Drainage

Standard gutter

114mm wide plastic gutter to be installed at the base of the living wall to collect run off with 32mm outlet. Drainage connection by others to discharge to either the foul water or surface water drainage system

Alternative gutter

Pressed aluminium gutter 90x60x120mm with powder coat paint finish to agreed RAL colour with 32mm outlet. Drainage connection by others to discharge to either the foul water or surface water drainage system

## 9.7 Services

### 1. Mechanical and electrical services to the plant room

The following mechanical and electrical services are to be provided to the plant room by others:

Service	Location	Requirement
Mains Water into the Plantroom	Plant room	2—3 bar pressure
Drainage at Irrigation rig for overflow	Plant room	50mm min
Electrical Supply for irrigation rig	Plant Room	13 Amp single phase socket

Additional services required if rainwater harvesting included:

Service	Location	Requirement
Rainwater feed to Rainwater tanks	Plant room	TBC, location specific
Electrical Supply to mains water top up controller	Plant room	13Amp single phase socket

### 2. Mains Water

- The Water Supply (Water Quality) Regulations 2016
- The Water Supply Regulations 2017

### 3. Services outside the plant room

Following services to be provided by others:

## 9.8 Riser covers, copings and window surrounds

Service	Dimension	Details
Irrigation pipes, No. TBC	20/25mm LDPE pipe	To be free issue by Biotecture—pipe runs by the main contractor
Drainage route from the living wall	100mm DIA—max size	Drainage connections from the gutter at the base of the living wall to either the foul or surface water systems
Aerial Wire	5mm approx.	Free issue by Biotecture—install by the main contractor
Electrical supply for lighting if required		

(if part of the Biotecture scope)

Pressed aluminium to agreed RAL colour. Located top and sides of the planted panels inclusive of window head and reveals to conceal pipework. Fixings to be visible using pre-painted head to RAL colour to match flashing / cover strip





## 9.9 Testing

### 1. Fire Testing

See the IFC Group Engineering Assessment Report Reference PAR/16691/01

Following the fire testing by BRE the IFC report concluded:

‘Based upon the fire testing conducted and described in Section3, it is the opinion of IFC that if the Biotecture Ltd Living Wall System was manufactured, installed and maintained in accordance with the requirements of this engineering Assessment Report, then the following reaction to fire performance would likely be achieved: B-s3,d2’

This means that the performance criteria set out in Building Regulations Approved Document B: Fire Safety, can be met subject to the installation criteria set out in the Approved Document

### 2. Structure

See the Evolve report ‘Structural Engineering Assessment of Biotecture Living Wall System rev C dated 21st December 2017



## 9.10 Planting

### 1. Planting density

Plant spacing to be 60 plants per sq m to ensure long term plant health.

### 2. Plant species

All plants to be selected from the Biotechture plant database to suit the local climatic conditions, including aspect, wind conditions and shade

Plant species to be included in the living wall to be included as a series of plant matrices to create an overall planting pattern presented for sign off by the client prior plant orders and planting in the nursery. Planting design is to be based on client design discussions and the selection of species to suit the local climatic conditions

Usually plants are to be planted into the BioTile panels a minimum of eight weeks prior to installation. The eight week period must not include December, January or February.

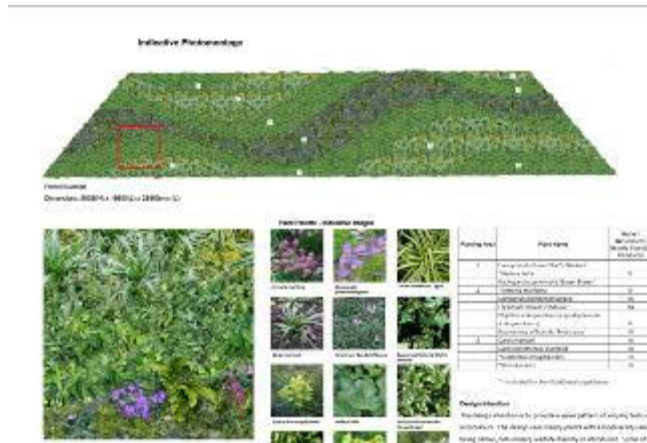
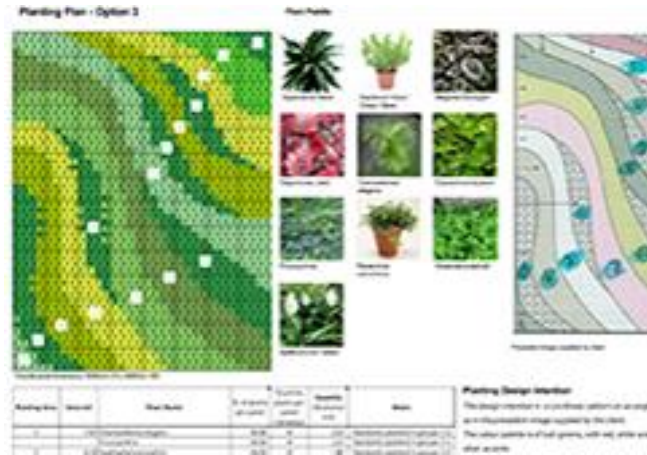



1.Planting Zones



2.Indicative Photomontage

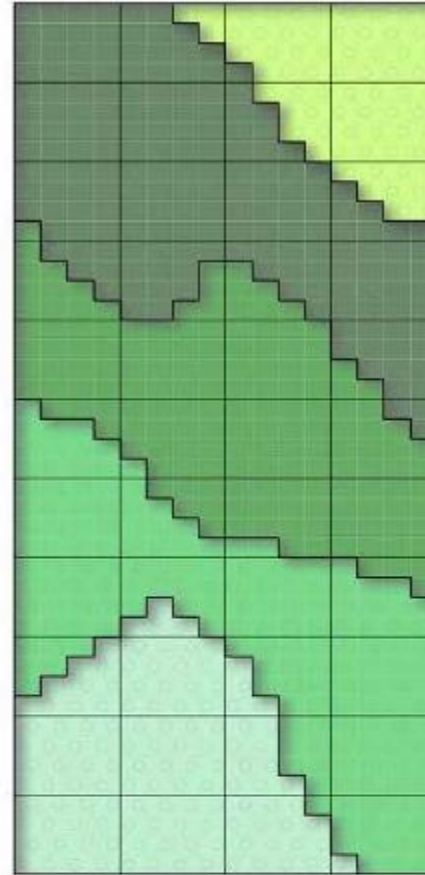

3.Panel Layout

## 9.11 Planting Design

Plant species to be included in the living wall will be either in single species zones or a series of plant matrices to create an overall planting pattern presented for sign off by the client prior to plant orders and planting in the nursery (see image 1). Planting design is based on the client design discussions and the selection of species to suit the local climatic conditions. If necessary shading studies will be carried out prior to the planting design. Photomontage images may be produced as part of the planting design presentation (see image 2)

The signed off planting design will then be translated into panel layouts which form the basis for the panels being planted in the nursery (see image 3)

Plants are planted into the BioTile panels a minimum of twelve weeks prior to installation. The twelve week period must be sometime between March and November.



Asplenium scolopendrium



Bergenia 'Baby Doll'



Bergenia 'Baby Doll'



Heuchera 'Fire Chief'



Heuchera 'Plum Pudding'



Liriodaphne 'Big Blue'



Eucrymus fortunei



Euphorbia amygdaloides  
'Purpurea'



Hedera helix



Lonicera 'May Green'



Pachysandra terminalis  
'Variegata'



Polystichum acrostichum

## 9.12 Potential Planting Matrices

630 M2		Heavy Shade	%	0
High Level	HP1	asplenium scolopendrium	13%	2
	HP2	hedera helix shamrock	25%	4
	HP3	lonicera nitida maigrun	25%	4
	HP4	euonymus fortunei emerald galaxy	25%	4
	HP5	Linopse big blue	13%	2
			100%	



630 M4		Partial Shade	%	0
High Level	HP1	euonymus fortunei emerald galaxy	19%	3
	HP2	Campanula Portenschlagiana	19%	3
	HP3	lonicera nitida maigrun	31%	5
	HP4	euonymus fortunei emerald n gold	19%	3
	HP5	Linopse big blue	13%	2
			100%	



630 M6		Full Sun	%	0
High Level	HS1	euonymus fortunei emerald galaxy	25%	4
	HS2	lonicera nitida maigrun	31%	5
	HS3	Armeria Maritima 'Solanders'	13%	2
	HS4	euonymus fortunei emerald n gold	31%	5
			100%	



230 M1		Heavy Shade	%	0
Low Level	LH1	euonymus fortunei darts blanket	31%	5
	LH2	lonicera nitida maigrun	31%	5
	LH3	hedera helix wonder	25%	4
	LH4	polypodium vulgare	13%	2
			100%	



230 M3		Partial Shade	%	0
Low Level	LP1	euonymus fortunei darts blanket	31%	5
	LP2	patrysandra terminalis variegata	19%	3
	LP3	hedera helix wonder	19%	3
	LP4	polypodium vulgare	13%	2
	LP5	euonymus fortunei emerald galaxy	19%	3
			100%	



230 M5		Full Sun	%	0
Low Level	LS1	euonymus fortunei darts blanket	25%	4
	LS2	Carex Ice Dance	25%	4
	LS3	hedera helix wonder	19%	3
	LS4	patrysandra terminalis variegata	19%	3
	LS5	euonymus fortunei emerald galaxy	13%	2
			100%	



## 9.13 Potential Statement Plants



Erythrum 'Bowles Mauve'



Erigeron karwinskianus



Convolvulus creorum



Acorus gramineus 'Open'



Polystichum setiferum



Bergenia 'Baby Doll'



Urtica rubra



Carex 'Ice Dance'



Santolina chamaecypariss



Santolina rosmarinifolia

Hypericum calycinum



Item No.	Statement Plants:	Shade	Partial Sun	Sun
1	Erythrum 'Bowles Mauve'		Y	Y
2	Carex 'Ice Dance'	Y	Y	Y
3	Carex monnifolia 'Irish Green'		Y	Y
4	Euphorbia wulfenii		Y	Y
5	Acorus gramineus 'Open'	Y	Y	Y
6	Polystichum setiferum	Y	Y	
7	Heuchera Lime	Y	Y	Y
8	Heuchera 'Marmalade'	Y	Y	Y
9	Heuchera 'Green Space'	Y	Y	Y
10	Heuchera 'Fire Chief'	Y	Y	Y
11	Heuchera 'Palace Purple'	Y	Y	Y
12	Polystichum polyblepharum	Y	Y	Y
13	Bergenia 'Baby Doll'	Y	Y	Y
14	Santolina	Y	Y	
15	Urtica rubra	Y	Y	Y
16	Convolvulus creorum		Y	Y
17	Lavandula 'Hidcote'		Y	Y
18	Erigeron karwinskianus		Y	Y
19	Hypericum calycinum		Y	Y
20	Santolina chamaecypariss		Y	Y
21	Santolina rosmarinifolia		Y	Y
22	Viola	Y	Y	Y
23	Hydrangea		Y	
24	Phlox			Y
25				



Heuchera 'Marmalade'



Heuchera 'Lime'



Heuchera 'Fire Chief'



Heuchera 'Key Lime Pie'



Lavandula 'Hidcote'



### Notes:

- 1 Full design and sign off to be by Client & Biotope
- 2 Plants subject availability
- 3 Substitutes may be required - subject to confirmation
- 4 Plants are likely to display different colours and flowers at different times of the year

## 9.14 Production



### Nursery:

1. The panels prior to planting
2. The panels are planted based on planting design.
3. The plants grow for a minimum of eight weeks

### Site:

4. The waterproof backing fixes to cladding rails.
5. Drainage layer and irrigation driplines are attached.
6. The living wall is complete. (Synergy House, Holborn)





## 9.15 Living Walls that Last

Technological advances in recent years have allowed the living wall industry to flourish. Combining these innovative developments with comprehensive horticultural expertise has allowed the industry to move past previous limitations and concerns.

Biotecture's hydroponic living wall embodies these characteristics to precisely monitor the health of our walls for longevity and resilience. Biotecture has installed over 200 vertical gardens including Europe's largest living wall at the Veolia Recycling and energy recovery facility, Leeds.

Dripline irrigation is used to precisely control the volume of water our living walls receive, whilst remote monitoring from our office allows the duration, frequency and timing of the irrigation to be meticulously regulated and adapted according to the needs of the plants throughout the year. Biotecture have been supplying, installing and maintaining living walls since 2007.

The long-term health of the wall is assured from the beginning, with maintenance and accessibility considered early in the design process. The plant species are thoughtfully chosen to suit the characteristics of the wall, such as the location, aspect and microclimate, among others.

Extensive monitoring and trialling of plant species across the years has allowed us to establish the most successful species for living walls.

Biotecture maintain over 100 living walls. We have an excellent and fully trained in house team of maintenance horticulturalists and technicians and we work to long term key performance indicators to ensure the health and visual quality of our botanic installations are kept at the highest level possible



# 10. Maintenance

*(subject to separate maintenance contact)*

## 1. Maintenance Statement

- The living wall is to be designed and assembled to enable safe and easy access for cleaning, maintenance and parts exchange.
- The maximum frequency of inspection of the wall as part of any maintenance agreement is to be 28 days.
- Wherever possible maintenance tasks shall be designed and engineered to be conducted from ground level
- Wherever possible natural biological controls are to be used.
- Routine should be to replace individual plants rather than replacing whole panels

## 2. Key performance indicators

- Irrigation system function = at least 95% of the times when it should function
- Visual aspect of wall = minimum 95% wall coverage by alive plants at all times
- The actual irrigation flow rate is within 20% of the design flow rates at all times
- Water consumption requirements = a maximum fresh water consumption of 1 litre per m<sup>2</sup> per day as an annual average
- Wastewater = a maximum waste water discharge of 0.2 litres per m<sup>2</sup> as an annual average





### 3. Maintenance Annual Schedule

Maintenance Operation	Jan	Feb	Mar	Apr	May	Jun	Jul	Aug	Sep	Oct	Nov	Dec
Bi-Monthly visual and photographic inspection of the wall	•		•		•		•		•		•	
Addition of bio-controls to the irrigation system				•					•			
Full access visit to prune/tide/replace background planting as necessary				•		•			•			
Daily Check of the remote sensing irrigation log and moisture metres	•	•	•	•	•	•	•	•	•	•	•	•
Topping up nutrient tank as necessary			•			•			•			
Pressure test irrigation system plant room components			•									
Strip, service and re-install dosing unit including by-pass until March											•	
Take dosing unit off by-pass system and re-engage			•									
Flush out all irrigation lines and check											•	

### 4. Maintenance Agreement

As well as the Performance Specification, which guarantees the long-term health of the wall, Biotecture will work to the following Maintenance Agreement. The key points within the maintenance agreement are as follows: Maintenance, monitoring and upkeep of the green wall elements and ancillary plant

#### 1. Statement of Intent

To signify the commitment of all parties both to this agreement and to the provision of sufficient resources to maintain the living green wall to a good standard at all times

#### 2. Inspection & Reporting

Biotecture will make regular visual and photographic inspections of the green wall areas (all from ground level). These will be carried out at suitable prescribed intervals throughout the year. Biotecture will carry out an annual close-up detailed inspection of all the areas of the green wall using access equipment. Biotecture will produce reports on standard forms of all inspections carried out. These will be formally issued to all parties.

#### 3. Maintenance & Upkeep

Biotecture will carry out an annual maintenance of the green wall elements. This includes:

- Replacing (up to) 100% of the plants as necessary.
- Topping up the nutrients tank
- Tending of plants as necessary
- Maintaining the irrigation system

#### 4. Pump(s) & Irrigation / Dosing System:

It will be the responsibility of Biotecture to ensure that the pumps and irrigation system are inspected and (where required) serviced at regular prescribed intervals as necessary. It will be the responsibility of Biotecture to ensure that the dosing of the required nutrients is carried out at suitable intervals.

#### 5. Remote Monitoring of the Irrigation System (if installed)

Biotecture will remotely monitor the irrigation controller on a regular basis during working hours with regard to expected values. Biotecture may remotely amend irrigation run times and irrigation program start times to suit the requirements of the plants. Any exceptions to programmed or expected flows or any other observed anomalies will be investigated and resolved.

## Maintenance Agreement Continued

In the event that the exception is considered to be a responsibility of the End Client (i.e. observed power or water failure) Biotecture Ltd will seek to report any such event to the End Client within 2 business days of that event occurring and will always do so within 5 days notwithstanding the provision of section 5.2.

The End Client will be wholly responsible for any resultant actions and all consequential issues that may arise from any event as per section above. This may include, for example, additional visits, horticultural work, plant replacement, irrigation maintenance and will be itemised and undertaken by Biotecture Ltd on the instructions of the End Client.

### 6. Quality Control

- Sufficient resources are to be allocated to allow the Living Wall to be maintained to an acceptable standard.
- The criteria that determine the acceptable standard that must be maintained will be agreed between the parties.
- A review procedure is to be established to monitor quality control issues.

### 7. Access

- The End Client will provide unobstructed access to the location of the living wall to allow all scheduled and instructed maintenance and servicing works to be undertaken.
- The expected means of access to reach the plants themselves is normally via MEWP, and as part of this Agreement this will be provided in a safe and certified manner at all times necessary by Biotecture Ltd.
- A procedure for ensuring that access to enable any emergency maintenance and servicing work is always available will be established between both parties.

### 8. Sub-Contractors and Assignment Rights

- The End Client agrees that Biotecture Ltd may at any time employ Sub-Contractors to fulfil its obligations under this agreement.
- Biotecture Ltd may not assign their rights and responsibilities under these terms of agreement without the express written approval of the End Client. Approval is not to be unreasonably withheld.

### 9. Liaison

- Regular meetings (minimum once a year) between the parties to take place to discuss maintenance and upkeep issues including programming and condition.



#### 10. Financial Principles

- The End Client will pay Biotecture Ltd an agreed annual fee of [£TBC] (excl. VAT) to carry out the works as confirmed in sections 3 & 5 above, to be paid quarterly in advance.
- For items not included within the annual fee a schedule of rates will be agreed between the parties. These will allow for all foreseeable additional items of maintenance / upkeep / replacement / amendments that may be deemed necessary at any time during the term of the agreement.
- Any unforeseen maintenance / upkeep / replacement / amendment requirements are to be evaluated and agreed prior to being carried out. The basis for this evaluation, if possible, is to be the schedule of rates.
- The annual fee and the schedule of rates are to be index linked to the Retail Price Index.

#### 11. Term of Agreement

- [TBC] year(s), with option to extend if both parties are in agreement.
- Review and if necessary amendment of terms of this agreement after every one year.
- Notwithstanding the above should the End Client fail to fulfil their obligations in accordance with this Agreement such that the living wall is clearly not being allowed to perform well then Biotecture Ltd will have the option of terminating this Agreement.

## 11. Contacts

smas\*

Achilles

CHAS®



Biotecture Ltd

The Old Dairy, Ham Farm, Main Road, Bosham

West Sussex, PO18 8EH

[enquiries@biotecture.uk.com](mailto:enquiries@biotecture.uk.com)

+44 (0) 1243 572 118