

# Vacuum-mixer dryer, reactor Type VMT

Hot/cold - pressure/vacuum reactions  
for dry, moist and pasty goods.

The mixer dryer and reactor is suitable for powders, suspensions, pastes and dough (test trials are recommended). Drying is carried out gently but quickly, even if different rheological consistencies occur. The dryer can be used as a sterile apparatus. It meets the requirements of EHEDG and 3-A Sanitary Standards.

Manhole heatable, on the top, sanitary connections for rotational washing nozzles.

Mixing chamber and mixing tool are fully welded and polished.

Choppers can improve the drying process by deagglomeration (mechanically sealed).

Mixing chamber: ATEX Zone 20

Segment ball valve without cavity, vacuum and pressure resistant

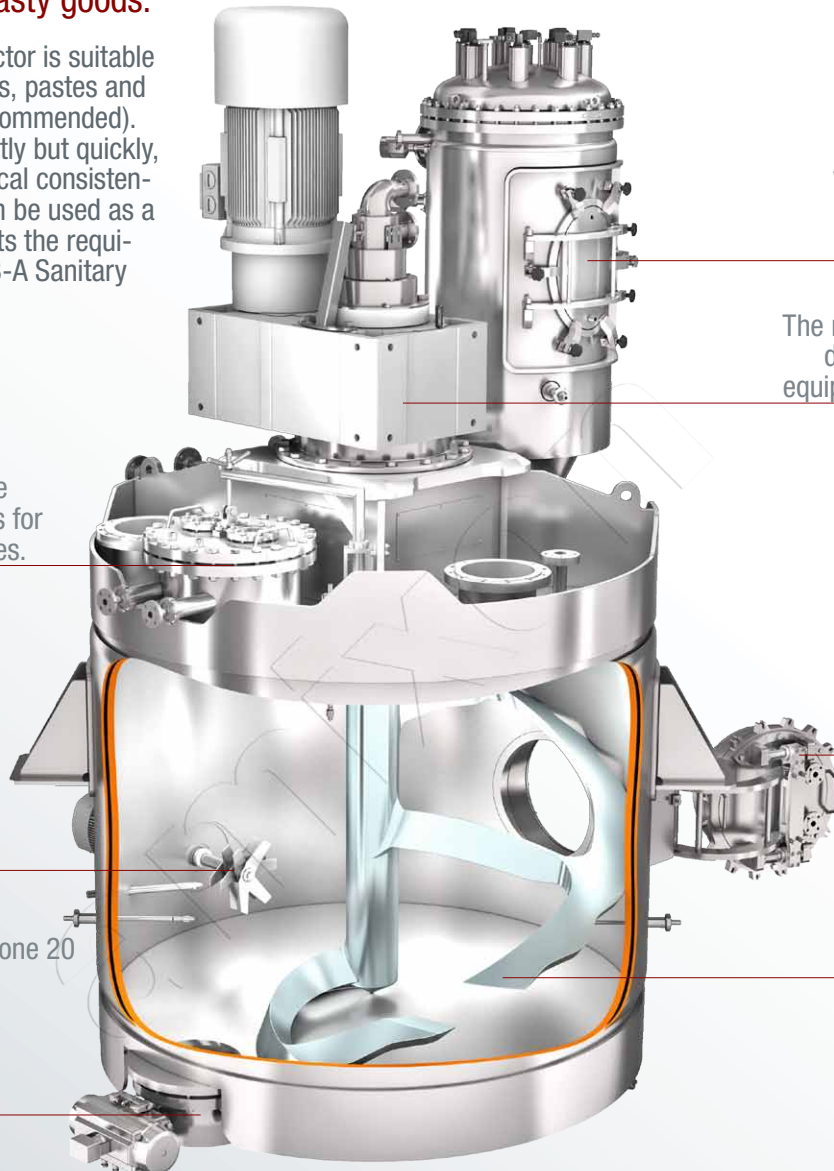

Vapour filter heatable; with Clever-Cut® designed inspection door on request.

The mixing tool is mounted and driven only on top; gear box equipped with a cooling device.

Manhole pressure tight with bayonet locking device; with displacer body to avoid dead space (heatable).

SinConvex® mixing tool: fully temperature controlled on demand, provides excellent mixing quality and discharge ability.

The reactor is vacuum and pressure tight and heatable by steam, thermal oil or water. On request also insulated.



VMT 200 made from Alloy 59



Upward moving in the periphery and downward moving in the center



Mixing shaft, mixing arms and spiral tool are heatable on demand.



LIFESCIENCE



FOOD



ANIMAL CARE



DETERGENTS



CERAMICS



POLY

## User Benefits

- ✓ Particularly fast and gentle drying at low temperatures and low rotational frequencies if, for example, fungal spores, bacterial cultures or effect pigments should be dried.
- ✓ It is also possible to mix intensively deagglomerating in the same apparatus, at higher peripheral speeds and with several HighShearBlades.
- ✓ The mixer is optional accessible from the side or from above, it can be cleaned fast, safely and convenient; manually or automatically. On request, it can also be sterilized with steam.
- ✓ The mixing tool is fully heated and mounted and driven only from above.
- ✓ The apparatus is highly gastight. A vacuum of 1 mbar abs. is possible.
- ✓ Particularly large heat exchange surfaces advantage extremely short drying times.

## Piloting

amixon® places special importance on the pilot phase in the test centre. Your mixing processes are simulated here. This way, we support you in your product development phase. amixon® has a main test center in Paderborn (Germany). Further test centers are situated in Japan, Thailand, India and the USA.



## Technical Data

Vacuum-mixer dryer, reactor <b>Type VMT</b> The type designation is equal to the batch size in liters. Ideal mixing even at low filling levels.	Approximate gross volume of the mixer	Approximate dimensions of the standard machines Please ask for detailed dimension sheets!						The rotational frequency can vary widely from about 0,8 m/s to about 3,5 m/s. Usually amixon® mixers-dryers, reactors operate at low speed.  About		The drive power required can vary widely depending on the bulk density, flow characteristics (viscoplastic phases), rotational frequency and the processing task (such as deagglomeration).		Weight may vary considerably depending on the size of the drive and the type of design. The additional dynamic loads are very low.  kg
		A	B	C	D	E	F	from	to	from	to	
		Liter = dm³	Liter	mm	mm	mm	mm	mm	mm	mm	mm	
100	130	386	637	1200	637	145	478	28	105	1	5	1000
200	260	456	787	1300	787	145	590	22	83	3	8	1420
300	390	486	737	1400	918	145	553	19	73	5	15	1680
400	520	486	918	1400	918	145	689	17	66	7	21	2050
500	650	486	908	1550	1038	145	681	16	61	8	27	2560
600	780	516	1038	1700	1038	145	779	15	57	10	31	3200
800	1040	536	988	1850	1218	145	741	14	52	12	40	3640
1000	1300	587	1218	1900	1218	145	914	13	48	14	48	5100
1500	1950	637	1389	2200	1389	145	1042	11	42	19	64	6200
2000	2600	737	1529	2300	1529	145	1147	10	38	22	78	7900
2500	3250	767	1569	2400	1569	145	1177	10	35	26	90	8200
3000	3890	787	1749	2600	1749	145	1312	9	33	29	101	9200
4000	5180	787	1910	2900	1910	145	1433	8	30	34	120	10100
5000	6470	888	2050	3200	2050	145	1538	8	28	38	137	13200
6000	7760	888	2190	3200	2190	145	1643	7	26	43	153	15800
7000	9040	938	2090	3400	2440	145	1568	7	25	47	167	17200
8000	10330	938	2410	3400	2410	145	1808	6	24	50	180	18800
9000	11610	1038	2040	3750	2841	145	1530	6	23	54	193	19500
10000	12890	1138	2240	4100	2841	145	1680	6	22	57	205	21200
12000	15460	1138	2540	4100	2841	145	1905	6	21	63	227	24000
15000	19300	1138	3141	4400	2841	145	2356	5	19	71	257	26400
17000	21860	1288	2841	4500	3211	145	2131	5	19	76	275	28200
20000	25700	1539	2741	4800	3471	145	2056	5	18	83	300	31000
25000	32080	1639	3592	5100	3471	145	2694	4	16	94	339	35600
30000	38470	1639	4162	5100	3471	145	3122	4	15	104	374	40100
40000	51210	1639	4292	5300	3862	145	3219	4	14	121	436	49600

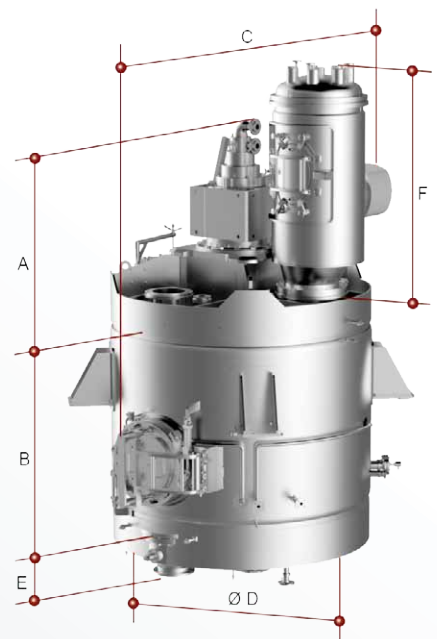

- Usually the vessel dimensions are relatively cubic, so that the height of the cylinder corresponds to the diameter. If desired, amixon® can modify the proportions: "low profile" if the height is limited or "slim profile" if the available ground area is limited.
- As a welding specialist, amixon® is qualified by European, Japanese and American authorities with regard to different materials. The materials in contact with the mixing goods are either mild steel S355J2Ge, Hardox, austenitic stainless steels 1.4301, 1.4541, 1.4571, 1.4404, 1.4539, 1.4529, Duplex stainless steels 1.4462, 1.4162, 1.4363, and Alloy 59-2.4605, Hastelloy C22 and nickel.
- The mixers meet the highest hygienic requirements and comply with the EHEDG guidelines for dry and wet cleaning. The mixers also meet the FDA hygiene guidelines and the design requirements of 3-A Sanitary Standards.



amixon GmbH  
Halberstädter Straße 55  
33106 Paderborn  
Germany

Tel. +49 (0) 52 51 / 68 88 88-0  
Fax +49 (0) 52 51 / 68 88 88-999  
E-Mail sales@amixon.com  
www.amixon.com



amixon® manufactures high precision mixers, vacuum mix-dryers, synthesis reactors and granulators with maximum fabrication depth. All components of the amixon®-mixers are made in Germany. The production of the machines takes place exclusively in the amixon®-factory in Paderborn, Germany.

© by amixon GmbH, Paderborn. Reprinting or transfer to electronic media only permitted after written approval. We reserve the right to make changes due to progress in process engineering and manufacturing technology.