

# RCKu

Horizontal plastic pump





# RCKu

## For small capacities

The RCKu is a cost-effective horizontal bearing bracket pump for smaller capacities below the standard.

The flange motor pump RCKuF has evolved from the basic model and is identical to it except for the drive. It is driven by an internally flanged standard motor on whose shaft the pump shaft is mounted, which accommodates the impeller and shaft seal.

This design solution results in a cost-effective and space-saving construction.

### Design features

- Design: horizontal, single-stage
- Casing design: single volute casing
- Bearing lubrication: grease lubrication
- Installation versions:
  - Base plate, base frame or stilt mounting
- Motor coupling: direct coupling or freewheel coupling
- Ambient temperature: -20°C to +60°C (-4°F to +140°F)
- Solid content limit value: approx. 5%



RCKuF

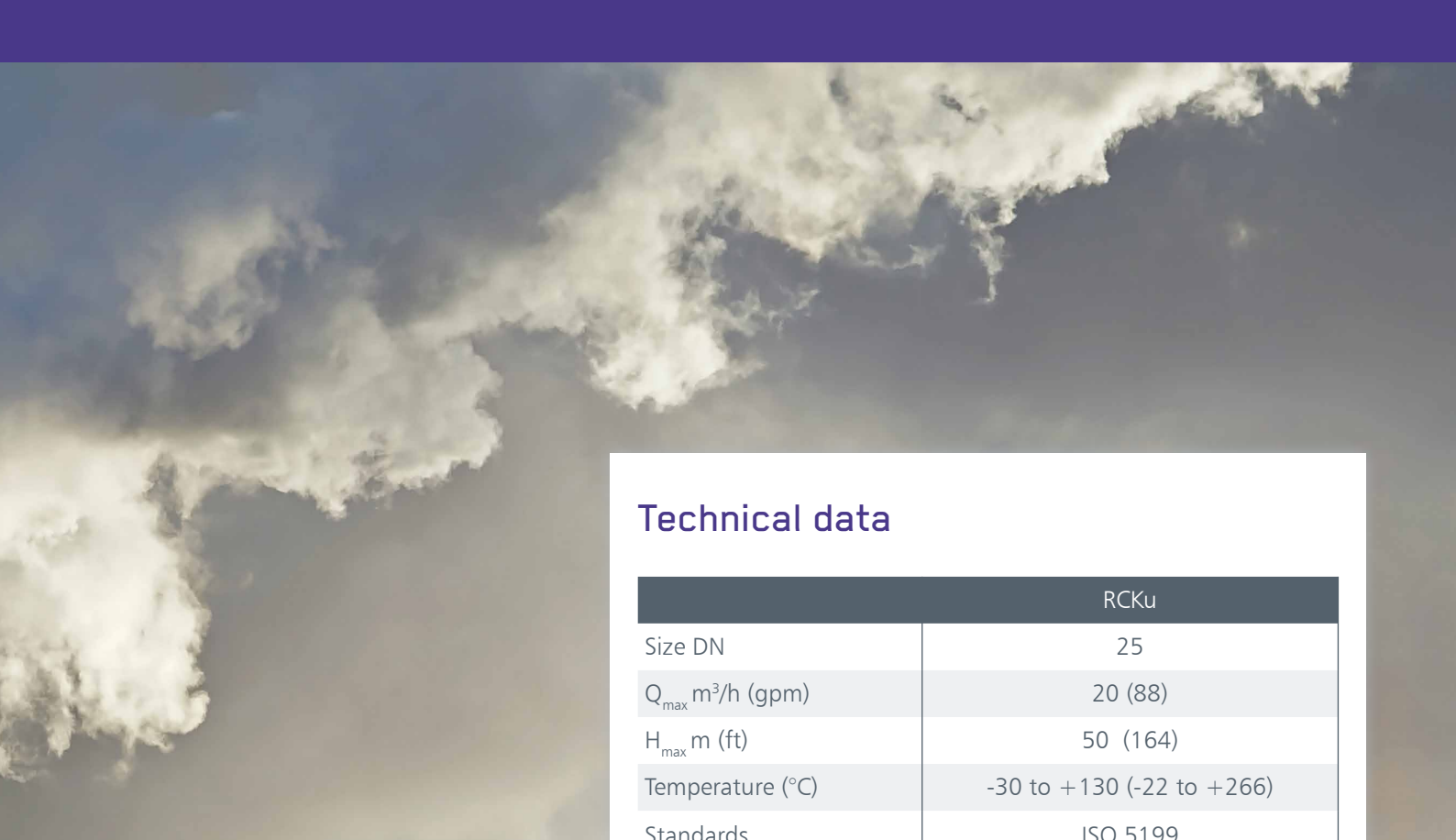

## Technical data

	RCKu
Size DN	25
$Q_{max}$ m <sup>3</sup> /h (gpm)	20 (88)
$H_{max}$ m (ft)	50 (164)
Temperature (°C)	-30 to +130 (-22 to +266)
Standards	ISO 5199
Open impeller	Standard
Flange motor design	RCKuF
Seal	Mechanical seal

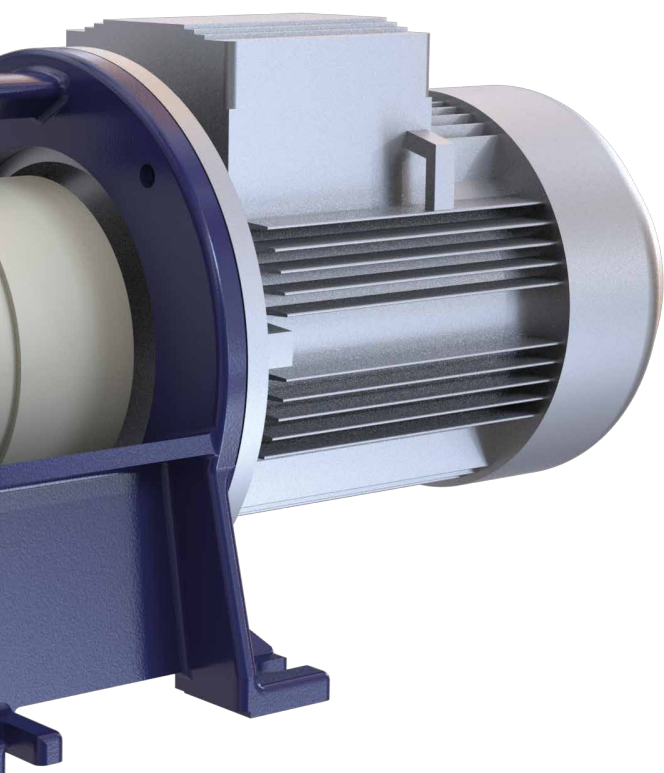

## Options

- Drain of volute casing
- Flushing in different versions
- Temperature and vibration monitoring
- Flange connections according to international standards
- Thermosiphon system
- Quench system
- Storage and priming tank
- Pump accessories

## Typical applications

- Brine
- Chemical waste water
- Chloralkali electrolysis
- Flue gas scrubber (waste incinerators)
- Hydrochloric acid
- Scrubber
- Seawater
- Steel industry
- Sulphuric acid

# Plastic materials

Our material experts help you to choose the right material. Plastics are in particular demand in applications with high corrosion resistance requirements, in order to ensure a long pump life cycle.

## PP – Polypropylene

This plastic is particularly suitable for simple, common applications. It offers outstanding performance at temperatures from 0 to 100 °C (-32 to 212 °F). PP has proven its worth in acids, alkalis and saline solutions as well as in hydrochloric acid pickling.

## PVDF – Polyvinylidene fluoride

The partial fluorination of this polymer increases its chemical resistance many times over. PVDF is resistant to most solvents, acids and oxidants. PVDF is an optimum material for many applications in the chemical industry for temperatures from -20 to 130 °C (-4 to 266 °F).

## PE 1000 (UHMWPE) – Polyethylene

The outstanding feature of this high molecular weight polymer is its resistance to wear in case of solids in the pumped medium. There is also a wide range of corrosion resistance options. In the temperature range from -50 to +80 °C (-58 to 176 °F), PE 1000 is in many cases an alternative to stainless steels.



# Main features

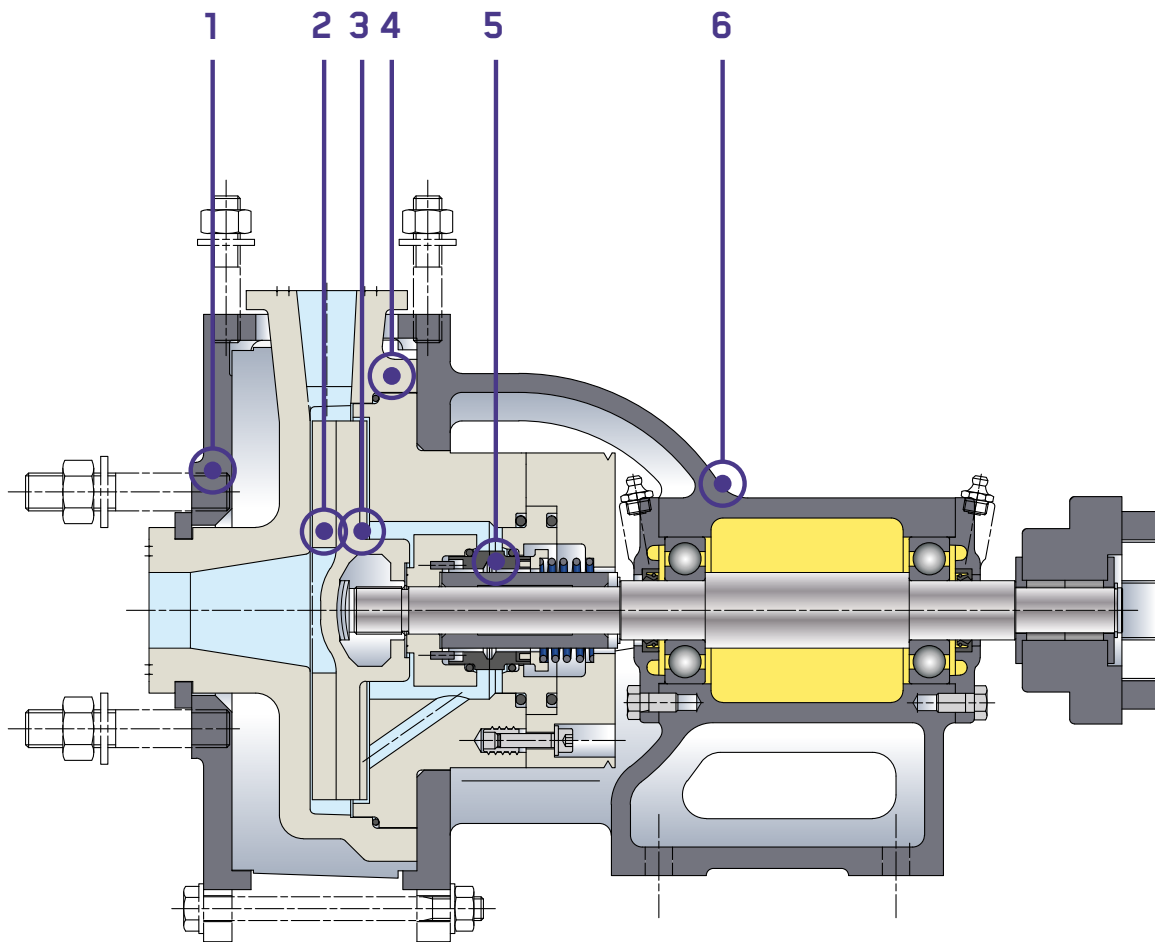

**1** Absorption of all external stresses by a robust metal armouring.

**2** The danger of clogging is minimised by using open impeller design.

**3** Axial thrust relieving by impeller back vanes.

**4** Maximum safety during operation through use of solid plastic construction.

**5** Operationally safe single mechanical seal without metal parts in contact with the media. Installation of double-acting mechanical seals possible.

**6** All metal parts are corrosion protected by multiple synthetic resin coating.

# Capacity ranges

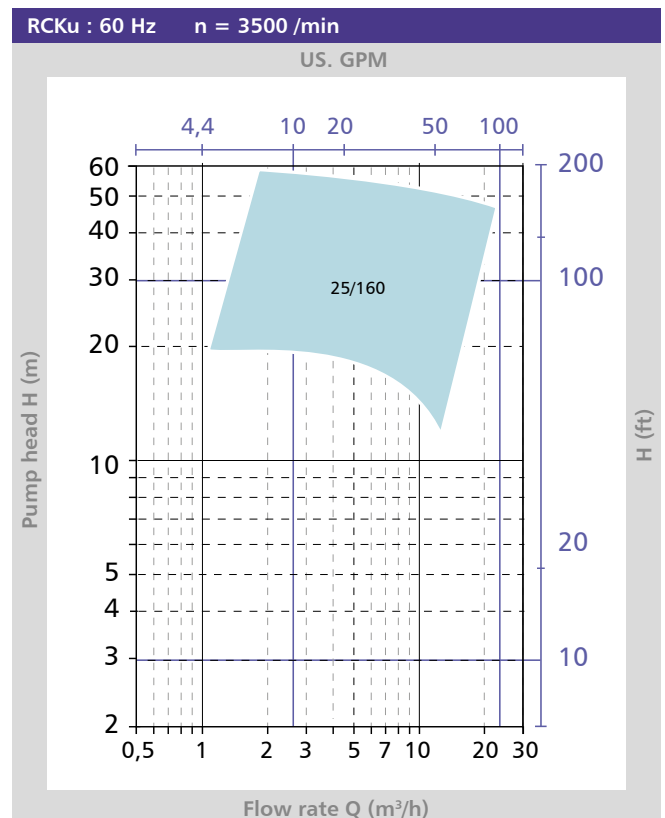
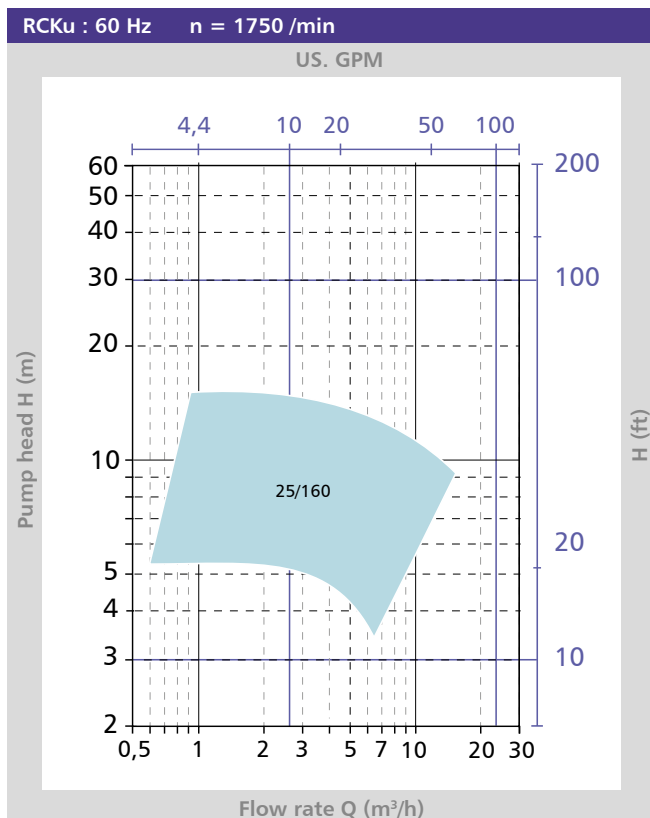
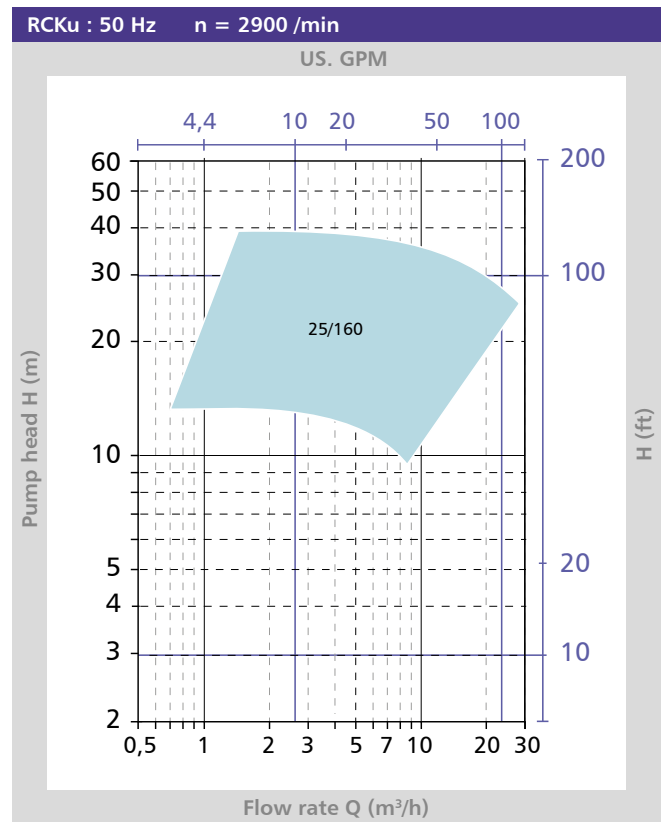
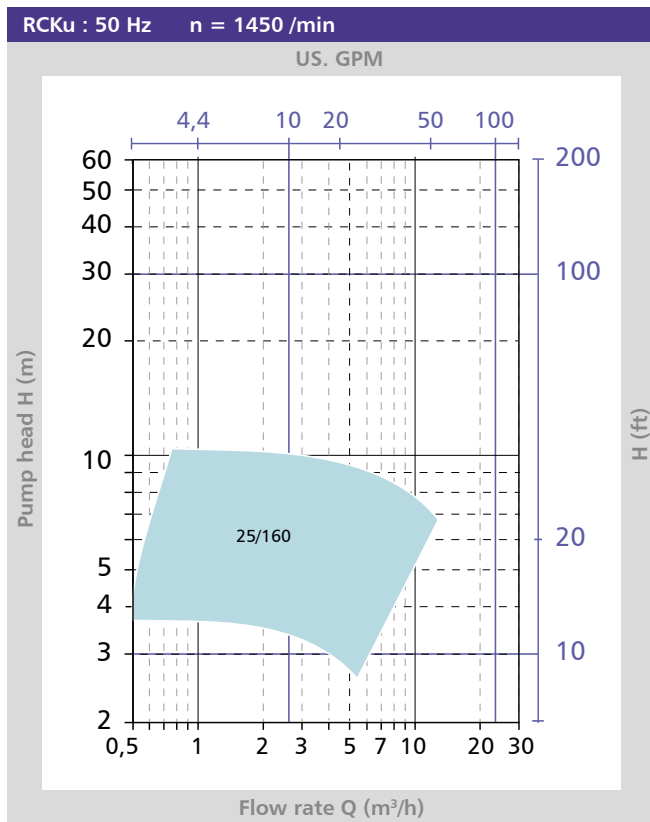

# Pumps & installation dimensions

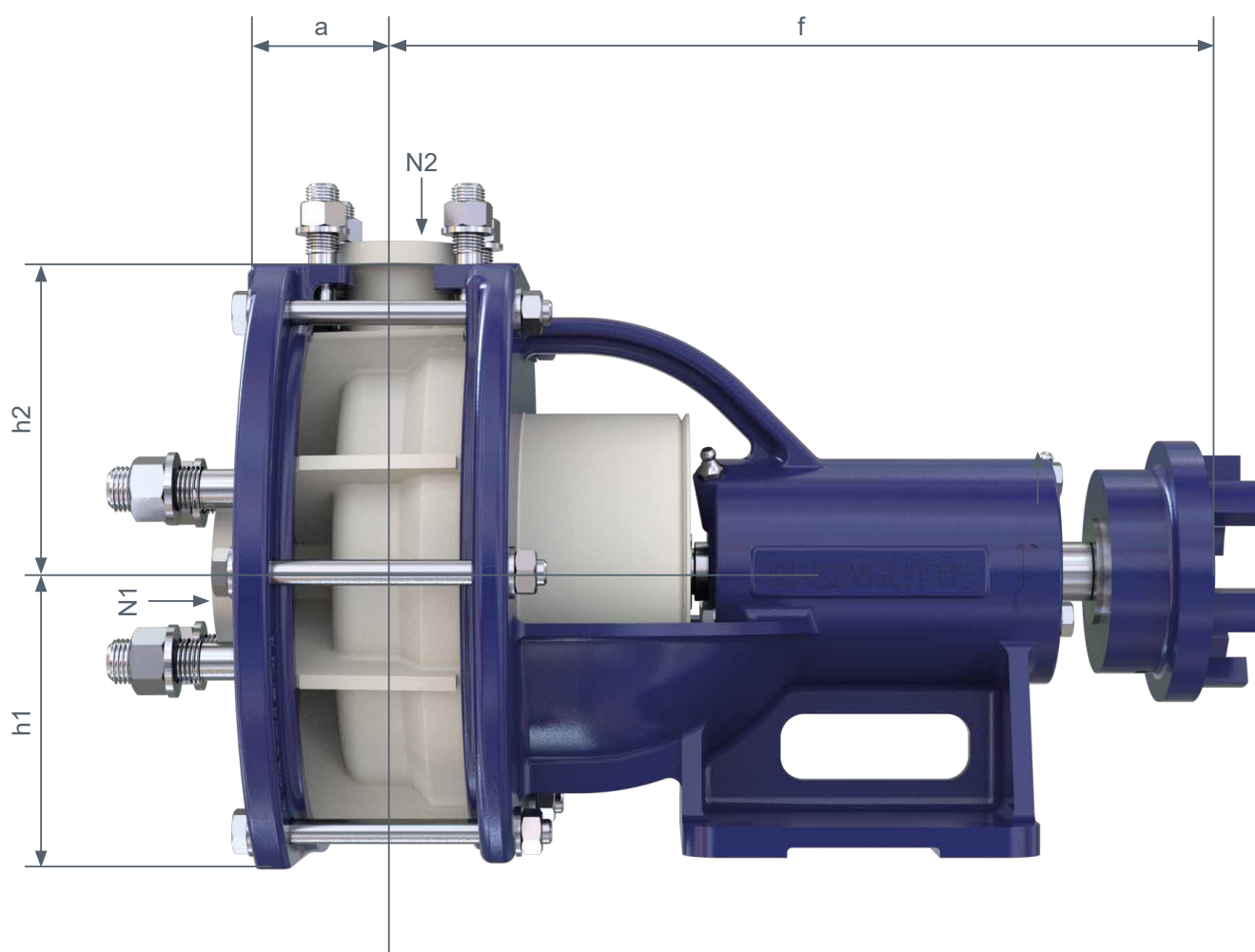

Size		BB	Pump dimensions				Flange dimensions	
			a	f	$h_1$	$h_2$	N2	N1
25/160	RCKu	1	75	335	118	135	25	32
25/160	RCKuF	1	75	190	118	135	25	32

BB = Bearing bracket N1 = Suction flange N2 = Pressure flange

All dimensions are shown in millimetres.



— An ITT Brand

ITT RHEINHÜTTE Pumpen GmbH  
Rheingaustraße 96-98  
D-65203 Wiesbaden  
T +49 611 604-0  
[info@rheinhuette.com](mailto:info@rheinhuette.com)  
[www.rheinhuette.de](http://www.rheinhuette.de)