

**SMCP - International**  
*Consultation et représentation*



**Des partenaires forts pour  
l'industrie**

- **Pharmaceutique**
- Alimentaire
- Cosmétique
- Chimique

**Programme de machines :**

**Production, conditionnement et le  
contrôle des produits sous forme  
sèche, liquide et pâteux.**

**Notre but c'est votre  
succès.**

Tel./Fax.: 0049 234 2397570

Mobile: 0049 173 26 72753

larbi.agdouche@t-online.de

Larbi.agdouche @smcp-international.com

**[www.smcp-international.com](http://www.smcp-international.com)**

**D-44801 Bochum**

**Germany**

## Machines de process forme sèche

### Granulation humide



Homogénéité: 1:100.000  
Durée mélange: max. 3 min.

Mélangeur horizontal



Mélangeur/Gr vertical



Lit d'air fluidisé



M/G/sécheur/Single pot



Turbine pelliculage



Dragéification

# Granulation à sec Compactage

Note: 99% poudres sont compactables

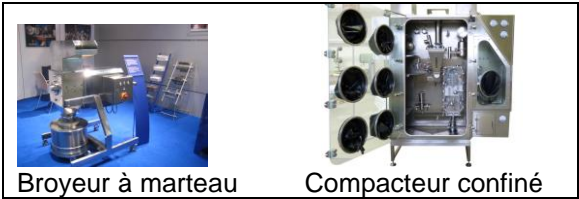
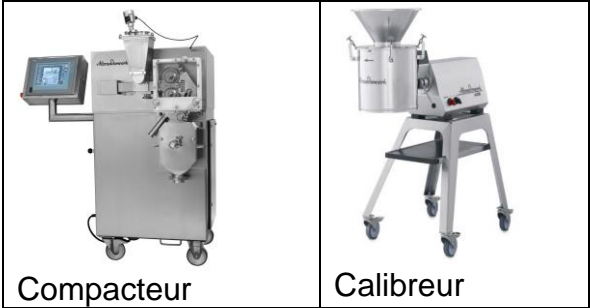

## Presses à comprimé et poinçons

Pour R&D et production + poinçons



## Tubeuse pour crèmes et pommades



## Machines de process forme liquide

Cuves de mélange et de stockage, homogénéisateurs

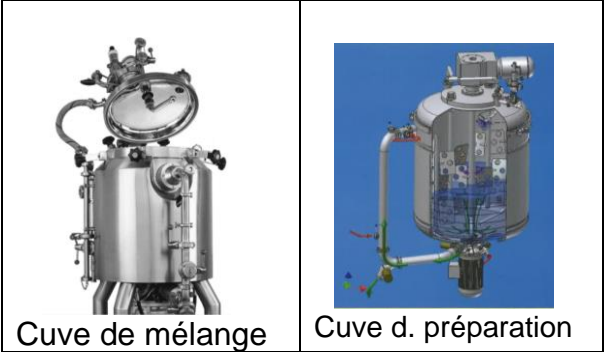

Cuve de mélange

Cuve d. préparation

## Lignes remplissage stérile (Seringues, vials, carpules ampoules, poches)

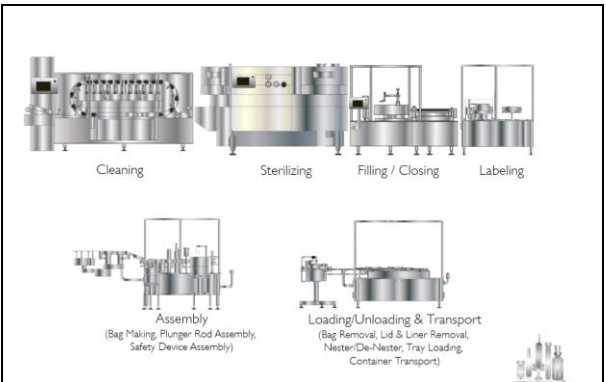

Ligne pour poches

## Ligne de remplissage sirops, colyres



## Lignes de conditionnement

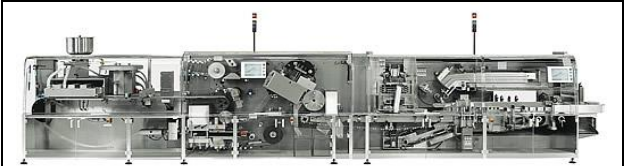

Ligne Blister complètement servo



Ligne sachet 4 soudures +stick

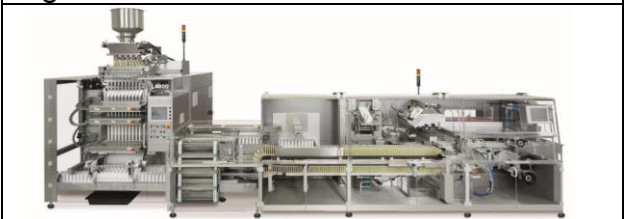

Ligne p. condi. sachets stick packs

# Machines d'Inspection

Tab lift/trieuses/mireuses/polisseuses



Caméras, détecteur fissures et code reader  
Upgrade des Blistéreuse des diff.marques



# Handling

Conteneurs, fûts, mélangeurs, potences, gerbeurs, stat. nettoyage, transpalettes etc.



# Check weighers, péluliers, doseurs



# Etiquetage/vignétage/impression/T&T

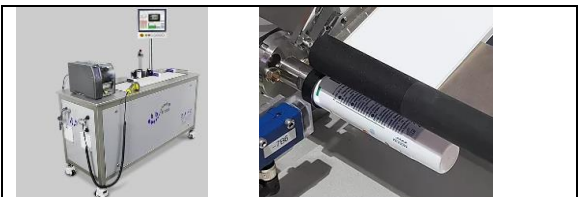



## Déblistérage, contrôle étanchié



D1500



D3600



D2500



Leak detection

## Equipements pour R&D et labo



Gél.autom.

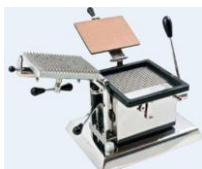

Gél. Semi autom.



Tablet press





Mono poinçon Ensacheuse

Blisitéreuse

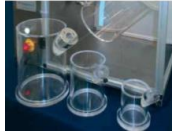

Mélangeur poudre

Cuves de mélange



Mélangeur en V

Machine p. Suppos



Mélangeur horizontal



Mélangeur vertical



Single pot



Sécheur



Coater

## Lyophilisateurs + autoclaves



# Salles blanches, HVAC, clef en main

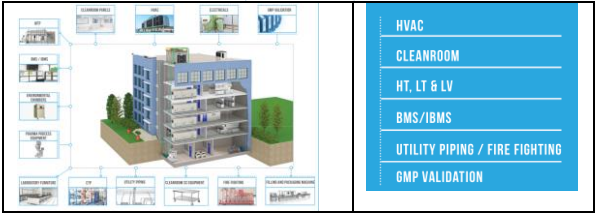

# Automatisation de l'usine PAS-X Réduction du papier à plus de 80%



## Complete Functional Scope

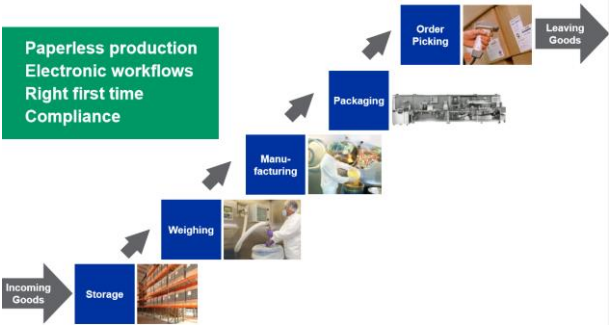

**Profitez des années d'expérience avec des partenaires forts dans le domaine.**

## Partenaires forts pour Pharma Qualité et Efficience



Mediseal



WERUM



*Cette brochure à uniquement l'aspect informatif, elle ne représente aucune offre et aucun engagement vis-à-vis des personnes tierces*