

Bandall Modular Range

- › *Very flexible integration of the various modules*
- › *Easily interchangeable*
- › *The banding unit can be rotated, enabling side-sealing or top-sealing*
- › *Signal exchange with other systems in line*

Separate modules from the successful and globally used Bandall banding machines are widely utilised as modular solutions.

Banding units, control cabinets and External Reel Holders can be integrated into individual packaging lines as required and in consultation with the customer. Bandall provides accurate 3D drawings in order to facilitate the integration of the Bandall modular model by your engineers.



Bandall has supplied an extensive range of modular banding solutions worldwide. We are happy to discuss your requirements.

Benefits

- › All modular solutions developed and installed can be supported by **Bandall's service and maintenance department**
- › **Complete integration** with various types of in-feed and out-feed conveyor systems
- › **Guaranteed high Bandall quality**
- › The banding unit can be simply added to with **a variety of options**
- › **100% Dutch design** and manufacture

Seamless integration,
full signal exchange,
streamline with the Bandall
Modular Range



Bundled Benefits

Bandall also regularly utilises modular banding units in the development of fully automatic installations, for example in multi-unit installations and other customer-specific installations. Furthermore, the compactness of the modular units enables easy replacement of banding systems or other packaging systems in existing production lines with new Bandall modular units.

Bandall Modular Range offers

- › **Various options** such as conveyor systems, data printers, External Reel Holders, etc
- › **Easy removal and replacement of banding** and other modules in line
- › **Maximum profit** from all of the benefits as provided by standard fully automatic Bandall equipment

Multi-unit equipment,
stacking unit, separation
system and printers. Pretty
much everything is possible

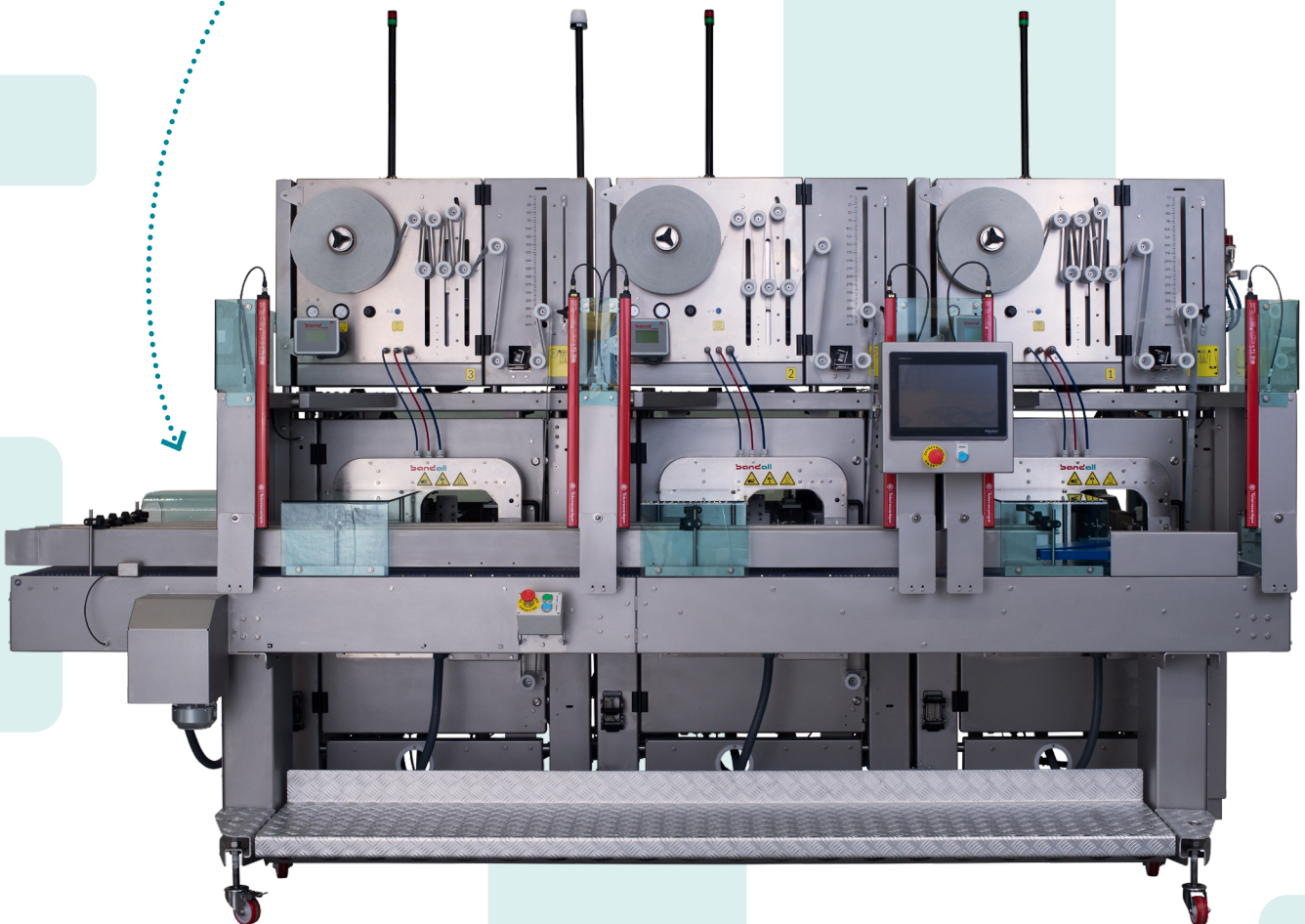



Rotate the banding unit
for a side sealing or top
sealing solution

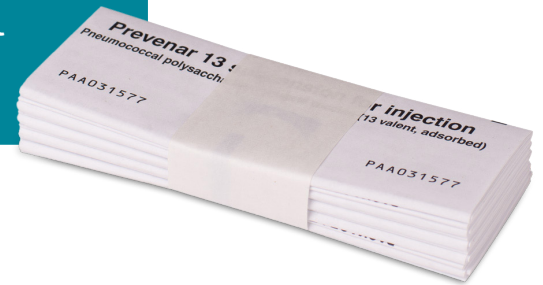
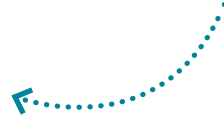

Professional preparation
Bandall ensures that all of the components
in modular solutions are prepared for direct
integration on the basis of a flexible signal
exchange with other systems.



The standard in fully automatic banding

Bandall modular bundling and banding solutions have been installed in line in the graphics industry, food industry, health & beauty and in many other packaging lines where a very efficient packaging process, reduction in packaging materials and often branding are required.

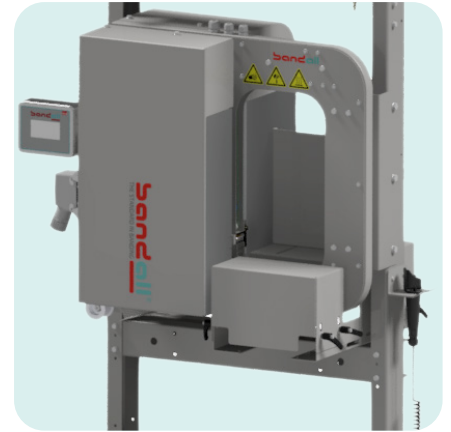

Modular advantages with Bandall

- › **Vast range of standard arch** widths and arch heights within the banding unit are available
- › Detailed information is available about **signal exchange**, software and components
- › **Short lead times**
- › **Reliable**
- › **User-friendly**
- › **Endless configurations**



The modular banding unit with a side seal is perfect for banding small products. Here it is integrated into a fully automatic line for banding labels

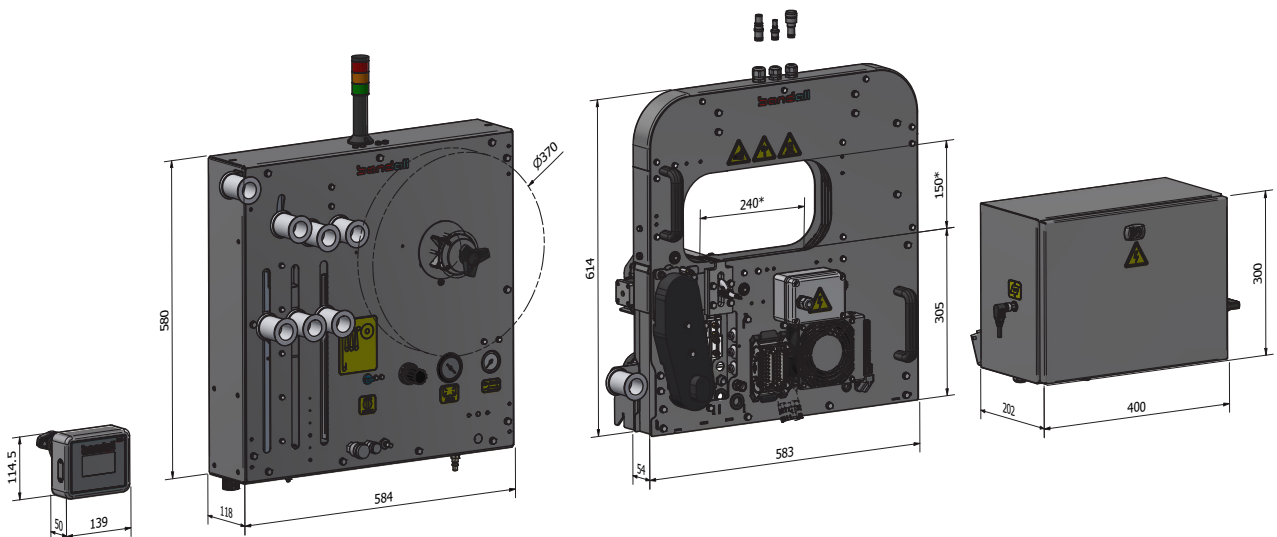

* The width, length and height of the banding arch are available in different sizes.

