

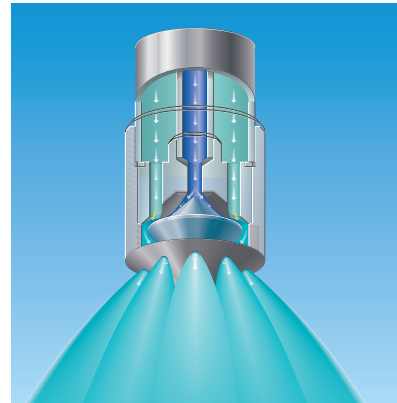

VarioCool®

Nozzle lances and systems
for gas cooling and conditioning

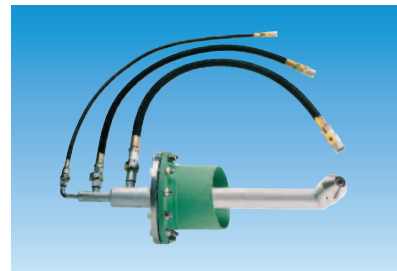

NOZZLE LANCES AND GAS CONDITION ENGINEERED AND MADE BY LECHLER

Lechler nozzles have been setting standards in quality, performance and design for over 130 years.



A wide range of specially developed and proven nozzles made from a variety of materials are available for gas conditioning – including the right ones for your own applications.

You can also fall back on over 20,000 different Lechler nozzles – with new ones being added to the range daily!



- Optimised energy use
- Short start-up times
- High operational and investment security



Lechler is your innovative and reliable partner in all matters relating to gas conditioning and atomization technology, always with the aim of employing our expert knowledge to optimise your process quality.

In line with your needs, we can offer you everything from an individual nozzle lance to a complete pump and regulation unit, with everything controlled from a single source.

Profit from our know-how and service:

- Lance design tailored to suit your process
- Complete gas conditioning and gas cooling systems, including temperature control and process guarantee
- Commissioning by engineers with many years of experience
- Reliable, worldwide supply with spare parts
- On-site service and maintenance contracts



Nozzle development



Pump and regulation unit



Commissioning and training by Lechler staff

LET US OPTIMISE YOUR GAS COOLING PROCESS

Our work begins with a detailed joint analysis of the relevant process-related data, the various operating states and framework conditions, including a regard to energy consumption.

For this you have the support of a global network of representatives and the company's own expert advisors.

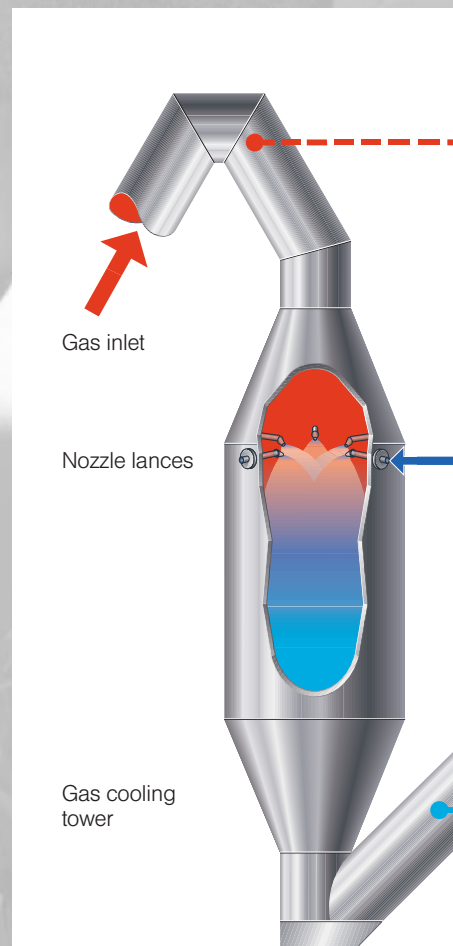

TAKE ADVANTAGE OF OUR SPECIALIST CONSULTANTS

Engineered by Lechler means:

- A joint analysis of the process data
- Gas cooling calculations using computer-supported numerical processes
- Determining the gas cooling tower dimensions
- Optimisation of energy use
- Support in the flow-related optimisation of gas cooling tower, both in new projects and in the upgrading of existing plants

Nozzles are selected and developed with the aid of the most modern methods and equipment that also cover the entire spectrum of measurements:

- Droplet size and velocity
- Flow rates
- Spray angle
- Spray pattern
- Spray videos

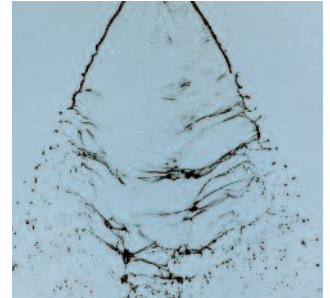

Droplet measurement (PDA)

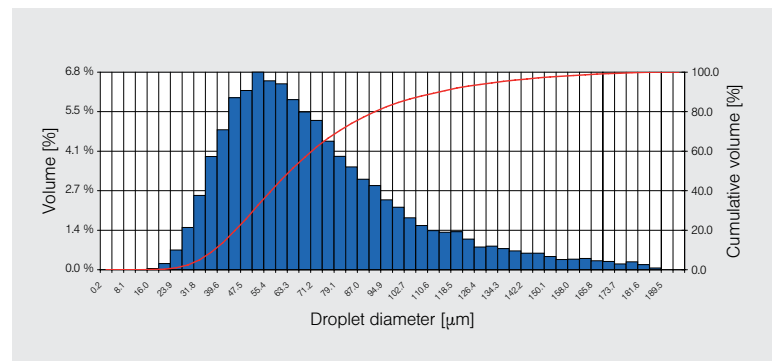
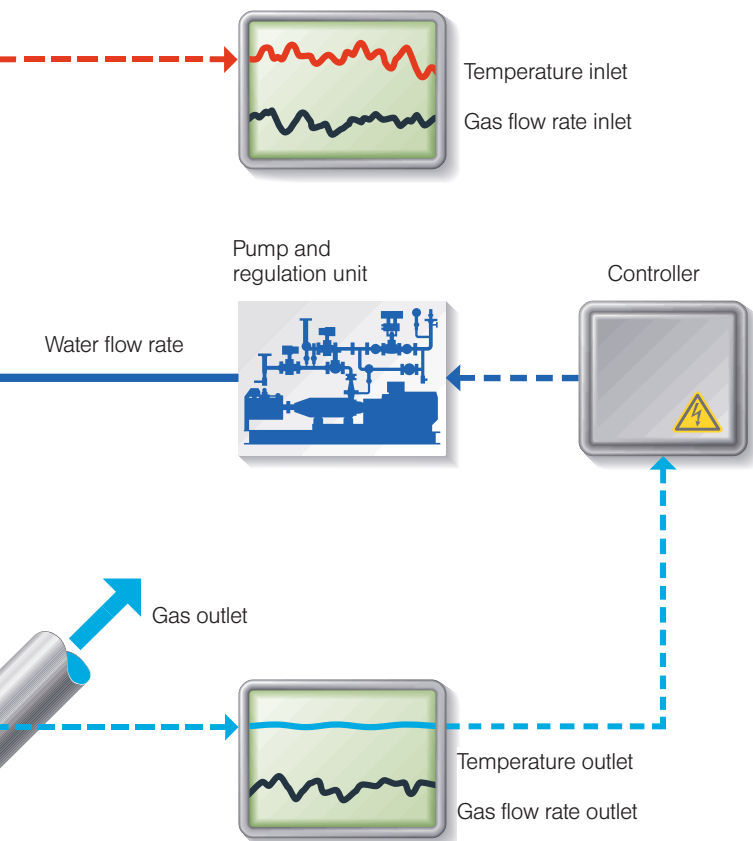

THE RIGHT NOZZLE...

Optimum results in gas cooling and gas conditioning processes are achieved only if detailed knowledge of the process-specific requirements are taken into account when making the nozzle selection.



... FOR YOUR APPLICATION

As a leading nozzle manufacturer, Lechler therefore attaches particular importance to the very careful selection of the nozzle design, and is able to fall back on a uniquely wide range of different functional principles.

Our nozzle lances and systems have proved themselves all over the world in the gas cleaning and conditioning systems of many plants:

- Cement and lime industry
- Metallurgy
- Power engineering
- Refuse incineration
- Glass industry
- Chemical industry

Besides gas cooling, they are also used in the following applications:

- Nitrogen removal (SCR / SNCR)
- Spray drying
- Spray absorption
- Spraying in water and fluids, e.g. in fluidised bed coolers, cylindrical rotary kilns, grinders etc.

Depending on the medium being sprayed in, the gas temperature and other framework conditions, the nozzles or nozzle components can be configured using a variety of materials:

- Stainless steel
- Heat-resistant stainless steel
- High-alloy stainless steels e.g. Hastelloy, Inconel, etc.
- Hard metal (tungsten carbide) for particularly abrasive media or ceramic for aggressive media
- Special materials



Refuse incineration



Power engineering



Cement and lime industry



Chemical industry



Metallurgy



Glass industry

SPILLBACK NOZZLES



- No atomization air required
- Low operating costs



Nozzle tips made of various materials: Hard metal, stainless steel, ceramic

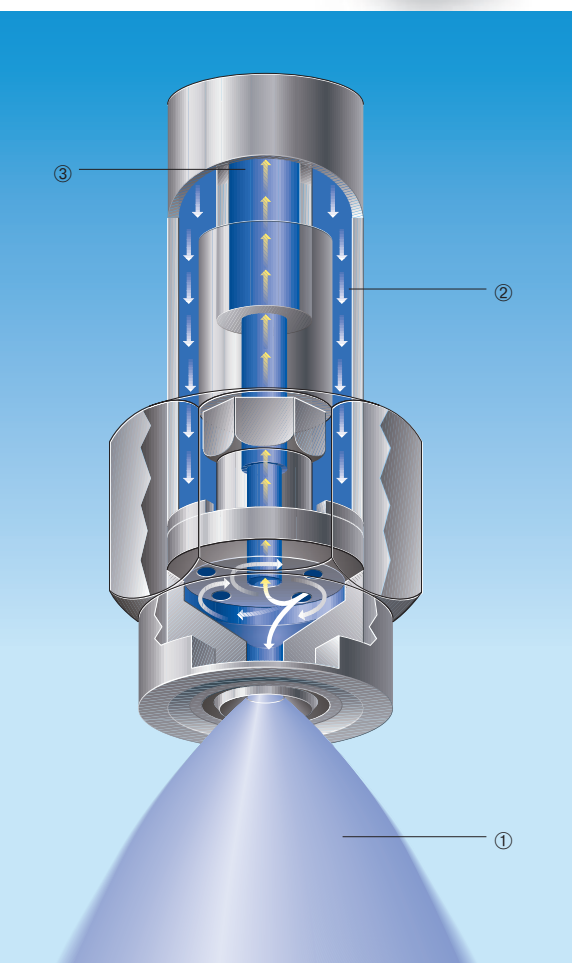

Lechler spillback nozzles atomize liquids as a fine hollow cone ①. Irrespective of the atomized flow rate, the medium is always carried to the nozzles at the same high pressure ②. Regulation is performed by opening a control valve in the spillback line ③, which takes a partial flow rate from the atomization and carries it back to the tank. The maximum atomized flow rate is achieved with the control valve closed. Even, fine liquid atomization is achieved across the entire control range.

Technical data:

Spray angle: 90°, 60°, 45°
 Turn down ratio: $\geq 10 : 1$
 Typical operating pressure: 35 bar (g)

Application example:

- Gas cooling in medium-sized and large gas cooling towers, e.g. in the cement, lime, glass and iron & steel industry

Cluster head speciality

If the volume to be atomized is divided between as many as six small spillback nozzles per cluster head, the droplet spectrum again becomes much finer than is the case with a comparable individual nozzle.



The cluster head's total spray angle of approximately 120° gives good distribution of the water spray and reduces the number of lances even in the case of large evaporator cooler cross sections. We also particularly recommend this possibility when upgrading existing gas cooling towers.



VarioJet®- NOZZLES



- Low air consumption
- Wide spray angle

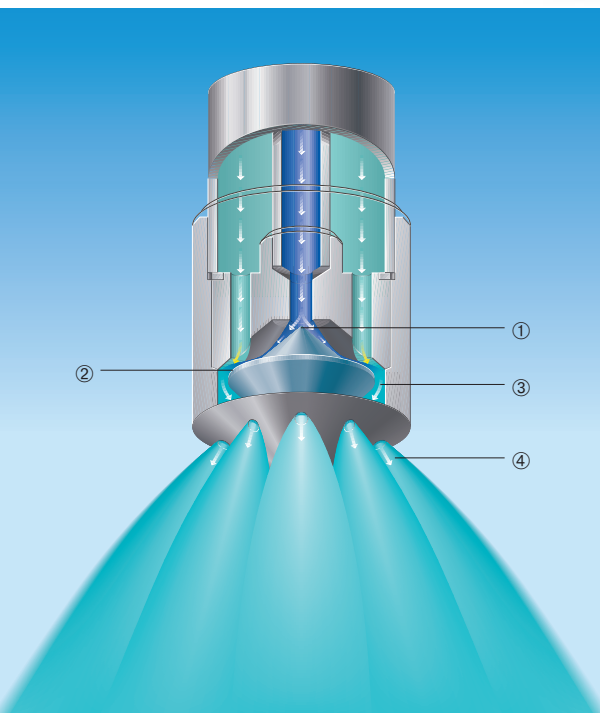

The liquid is fed in axially via a bore hole. After arriving at the cone tip, the spray is split up into a liquid film ①. At the separation edge, the gaseous medium atomises this thin liquid film into very fine droplets ②. The resulting gas / liquid mixture ③ then exits via several bore holes arranged in a circle pattern ④.

The new nozzle design creates a spray jet with a wide discharge angle, which boasts both even liquid distribution and a fine droplet spectrum combined with low specific air consumption.

Technical data:

- Spray angle: 60°
- Turn down ratio: $\geq 12 : 1$
- Typical pressure range:
Liquid 1 – 9 bar (g)
Atomization air 1 – 6 bar (g)

Application example:

- Gas cooling in medium-sized and large gas cooling towers and also pipes carrying gas (ducts), e.g. in the cement, lime, glass and iron & steel industry



LAVAL NOZZLES



- Very fine droplet spectrum
- Very high Regulation ratio
- Large free cross sections
- Ceramic design for optimum wear, e.g. for abrasive media such as milk of lime

Lechler Laval nozzles work on the supersonic principle.

A dual-phase mixture is created from gas ① and liquid ② in the mixing chamber inside the nozzle ③. The shape of the nozzle causes this mixture to be accelerated to supersonic speed ④. This results in extremely fine atomization of the droplets combined with a very high turn down ratio.

By changing the air / water ratio, the droplet size and the droplet spectrum can be adapted within a wide range. The large free cross sections of the nozzle also allow atomization of viscous liquids or of liquids loaded with solids. The correct choice of material prevents wear even where abrasive media are present.

Technical data:

- Spray angle: 15°
- Turn down ratio: 20 : 1 (in some cases up to 40 : 1)
- Typical pressure range: Liquid 1 – 5 bar (g) Atomization air 1 – 5 bar (g)

Application examples:

- Gas cooling in medium-sized and small gas cooling towers and also pipes carrying gas (ducts), e.g. in the cement, lime, glass and iron & steel industry
- Injection of lime water (slurry) in desulphurisation processes
- Injecting water loaded with solids
- Injecting ammonia water or urea solution for the DeNOx process (SCR / SNCR)
- Chemical process technology (spray drying etc.)

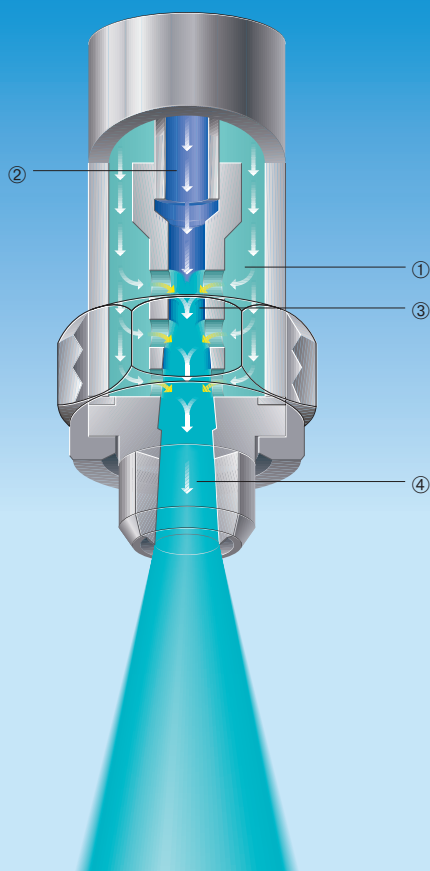

TWIN-FLUID NOZZLES WITH EXTERNAL MIXING



- Operation with air, various gases or steam as the atomization medium
- Emergency operating properties if the atomization medium fails

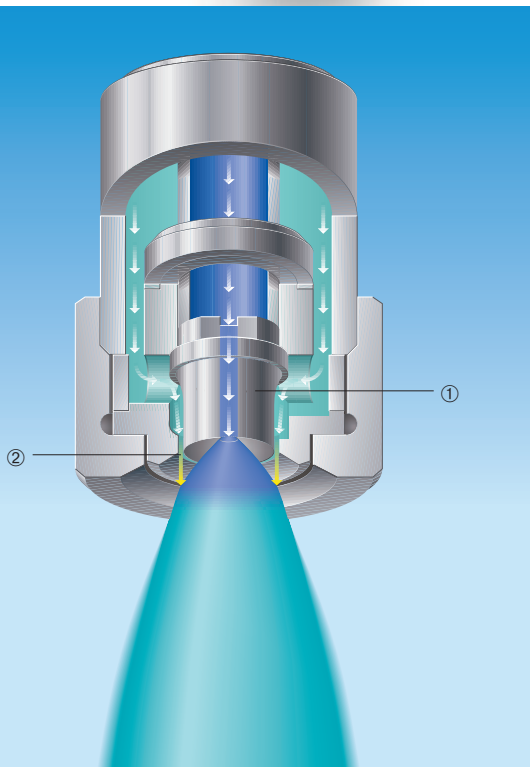

Lechler twin-fluid nozzles with external mixing generate a full-cone jet with a spray angle of up to 30°. The liquid is divided into a hollow cone ① in a special atomization unit and is then atomised into fine droplets by a gaseous medium fed in via an annular gap ②.

This means that liquid and gas are only mixed outside the nozzle body, thereby allowing steam to be used besides air and various gases.

Technical data:

Spray angle: 20 – 30°
Turn down ratio: 5 : 1
Typical pressure range:
Liquid 0,3 – 10 bar (g)
Atomization air / steam
1 – 5 bar (g)

Application examples:

- Gas cooling in medium-sized and small gas cooling towers and also pipes carrying gas (ducts), e.g. in the cement, lime, glass and iron & steel industry, power stations
- Chemical process technology

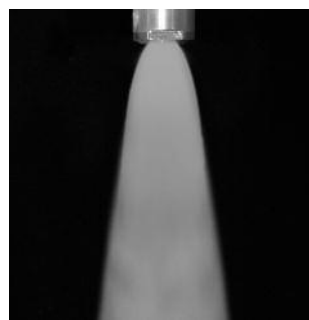

LECHLER NOZZLE LANCES

Lechler nozzle lances are available in many different designs and (with the corresponding nozzle type fitted in each case) are adapted specifically to your technical process and the local conditions.

The experience of our staff in on-site commissioning is continuously being incorporated into our lance designs.



PROVEN QUALITY, CONVINCING DOWN TO THE SMALLEST DETAIL

The robust, high-quality stainless steel construction ensures a high degree of functional reliability. A variety of materials are used here, depending on the requirements.

For example:

- Stainless steel
- Heat-resistant stainless steel
- High-alloy stainless steel for special temperature ranges and applications, such as Hastelloy, Inconel, etc.
- Special materials according to your specifications

The following optional design variants and accessory parts are also available:

- Protective tubes with a barrier air connection, e.g. for use in the presence of higher temperatures, aggressive gases and high dust loads
- Assembly connecting pieces with flange connector for welding into gas cooling towers, pipes carrying gases etc.
- Quick-assembly flange (Lechler tapered flange)
- Assembly aids
- Compensators for equalising different elongations
- Flexible length adjustment
- Insulated and water-cooled designs
- Wear-protection tubes
- Protective and non-stick coatings
- Pre-assembled accessory sets for the media connection (e.g. consisting of quick-release couplings, shut-off ball valves and hoses)

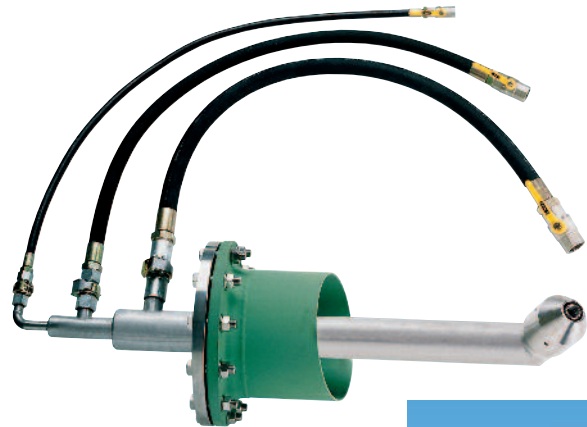

Example – Laval lance (with protective tube)

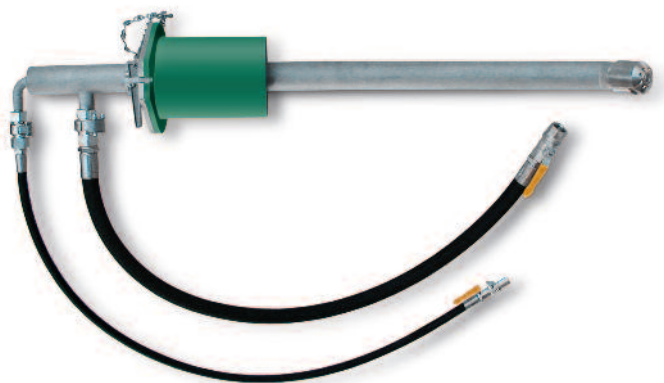
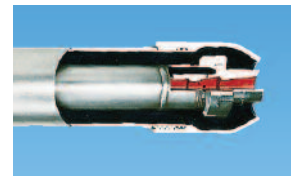

Example – VarioJet® lance

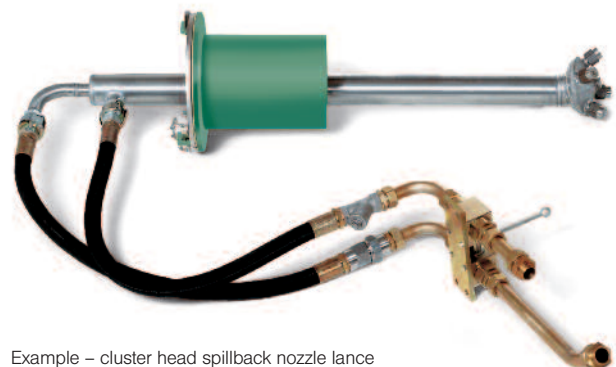

Example – cluster head spillback nozzle lance

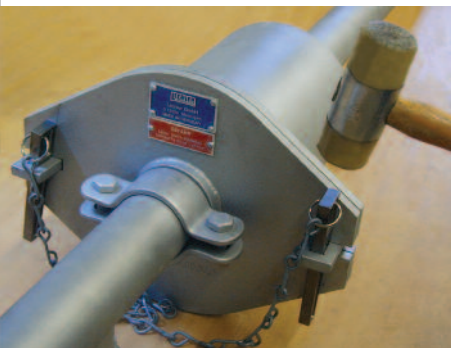

Design with tapered flange

VarioCool®

PUMP AND REGULATION UNITS

Lechler can supply you with completely pre-assembled and tested pump and regulation units with defined interfaces, the components of which are perfectly tailored to the function of the nozzle lances and their on-site connections.

- Gas cooling systems with process guarantee
- Minimum installation and commissioning time
- Exact adjustment to suit your operating states



PERFECTLY TAILORED SOLUTIONS

For example, the control valve is configured precisely to the operating parameters of the nozzle and of the pump, so as to achieve the widest possible control range. The equipment that we use has proved itself superbly in continuous operation in many applications. The right instrumentation for the job means that you always have the injection system under control.



Temperature regulation (switch cabinet, including control and operating panel) can be integrated onto the pump and regulation units.

Other options such as a modern for remote maintenance of the software are possible.

We use high-quality components from renowned manufacturers for the controller assembly. The program is tailored individually to the respective application and operating method.

We pre-commission the controller before it leaves our works. This minimises the amount of commissioning work on site.



Pump and regulation unit with temperature regulation

Our experienced staff are happy to provide you with support in commissioning and operator training.

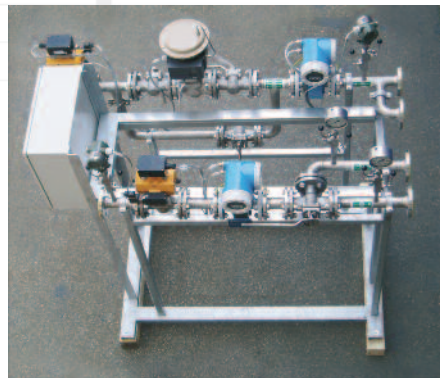

Regulation unit with wiring to terminal boxes

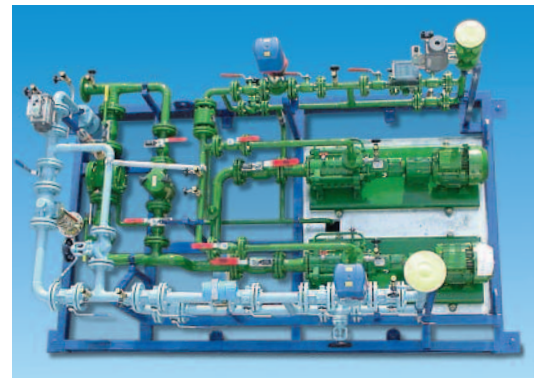

Pump and regulation unit



Lechler GmbH
Precision Nozzles · Droplet Separators
P.O. Box 13 23
72544 Metzingen / Germany
Phone +49 (0) 71 23 962-0
Fax +49 (0) 71 23 962-333

E-Mail: info.variocool@lechler.de
Internet: www.lechler.com

Are you planning a new gas conditioning or gas cooling system, or do you want to examine the possibilities of your existing systems?

Talk to us – our experts will offer you competent advice and will perform the necessary calculations for you.

Further information, contact partners and an enquiry form can be found on the Internet at www.lechler.de or send an e-mail to info.variocool@lechler.de



Belgium: Lechler S.A./N.V. · Avenue Mercatorlaan, 6 · 1300 Wavre · Phone: (10) 225022 · Fax: (10) 243901 · info@lechler.be
China: Lechler Intl. Trad. Co. Ltd. · Beijing · Rm. 418 Landmark Tower · No. 8 Dong San Huan Bei Lu · Phone: (86) 1084537968, Fax: (86) 1084537458 · info@lechler.com.cn
Finland: Lechler Oy · Jäspilänkatu 18 · 04250 Kerava · Phone: (358) 207856880 · Fax: (358) 207856881 · info@lechler.fi
France: Lechler France, S.A. · Bât. CAP2 · 66-72, Rue Marceau · 93558 Montreuil cedex · Phone: (1) 49882600 · Fax: (1) 49882609 · info@lechler.fr
Great Britain: Lechler Ltd. · 1 Fell Street, Newhall · Sheffield, S9 2TP · Phone: (0114) 2492020 · Fax: (0114) 2493600 · info@lechler.com
India: Lechler (India) Pvt. Ltd. · Plot B-2 · Main Road · Wagle Industrial Estate · Thane (W) · 400604 · Phone: (22) 40634444 · Fax: (22) 40634497 · lechler@lechlerindia.com
Sweden: Lechler AB · Spärrgatan 8 · SE-653 41 Karlstad · Phone: (46) 54137030 · Fax: (46) 54137031 · info@lechler.se
Spain: Lechler S.A. · Avda. Pirineos 7 · Oficina B7, Edificio Inbisa I · 28700 San Sebastián de los Reyes, Madrid · Phone: (34) 916586346 · Fax: (34) 916586347 · info@lechler.es
USA: Lechler Inc. · 445 Kautz Road · St. Charles, IL 60174 · Phone: (630) 3776611 · Fax: (630) 3776657 · info@lechlerUSA.com