



PrH

PRODUCT  
HANDLING

# HEALTHCARE & PHARMACEUTICAL SOLUTIONS



# HEALTHCARE & PHARMACEUTICAL SOLUTIONS

## THE SHUTTLEWORTH ADVANTAGE

### SANITARY DESIGN

- Suitable for class 100 (ISO Class 5) clean environments
- 316 SS available for chemical or irradiation applications
- Anti-microbial plastics are designed to inhibit bacteria

### SLIP-TORQUE™ TECHNOLOGY

- Slip-fit rollers minimize product damage
- Low line pressure provides gentle product accumulation
- Close roller shaft centers offer maximum product stability

### INNOVATIVE CUSTOM-ENGINEERED SOLUTIONS

- Modular design allows for future reconfiguration
- Ergonomic operator requirements may be incorporated
- Inherent safety of Slip-Torque design meets OSHA standards

Shuttleworth's new formed stainless steel frame design is suitable for most pharmaceutical and medical production environments.

## PRODUCTS HANDLED:

- Catheters
- Contact lens solution
- Contact lens trays
- Cosmetics
- Dental Floss
- Diagnostic Kit
- Eyeglass lens disks
- Gauze
- IV drip bags & bottles
- Joint Implants in baskets
- Medicated patches
- Nutraceutical bottles
- Pharmaceutical blister packs & bottles
- Sanitary diapers and pads
- Surgical Kits
- Syringes, ampoules, test tubes & vials in trays
- Toothpaste
- Wet Wipes – stacked raw, bagged, in tubs or cartons
- X-ray film

Chain Drive

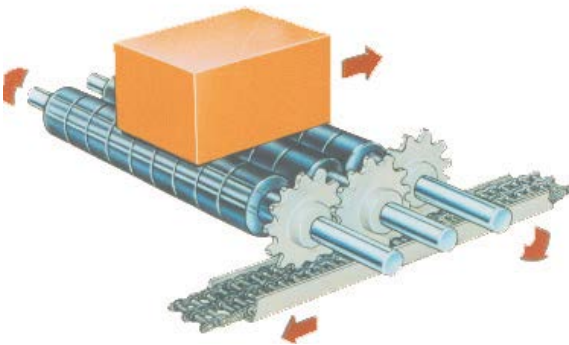

Belt Drive

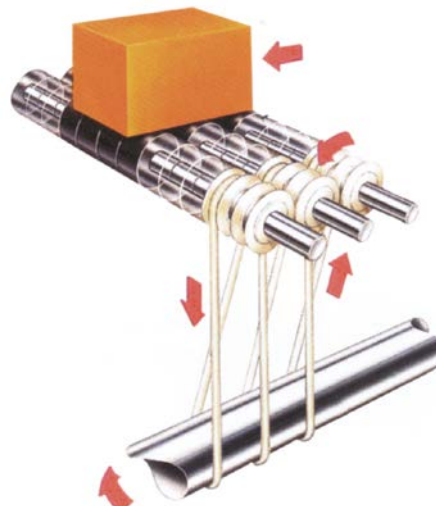

Available in chain or belt drive design.

## Kitting Applications



MANUAL TRAY LOADING

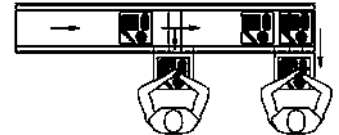

KIT ASSEMBLY

## IV Bag Applications

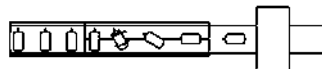

ROTATING / CENTERING

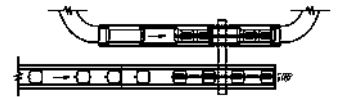
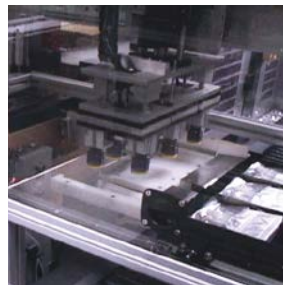

CASE PACKING



# PROVEN PRODUCT HANDLING SOLUTIONS

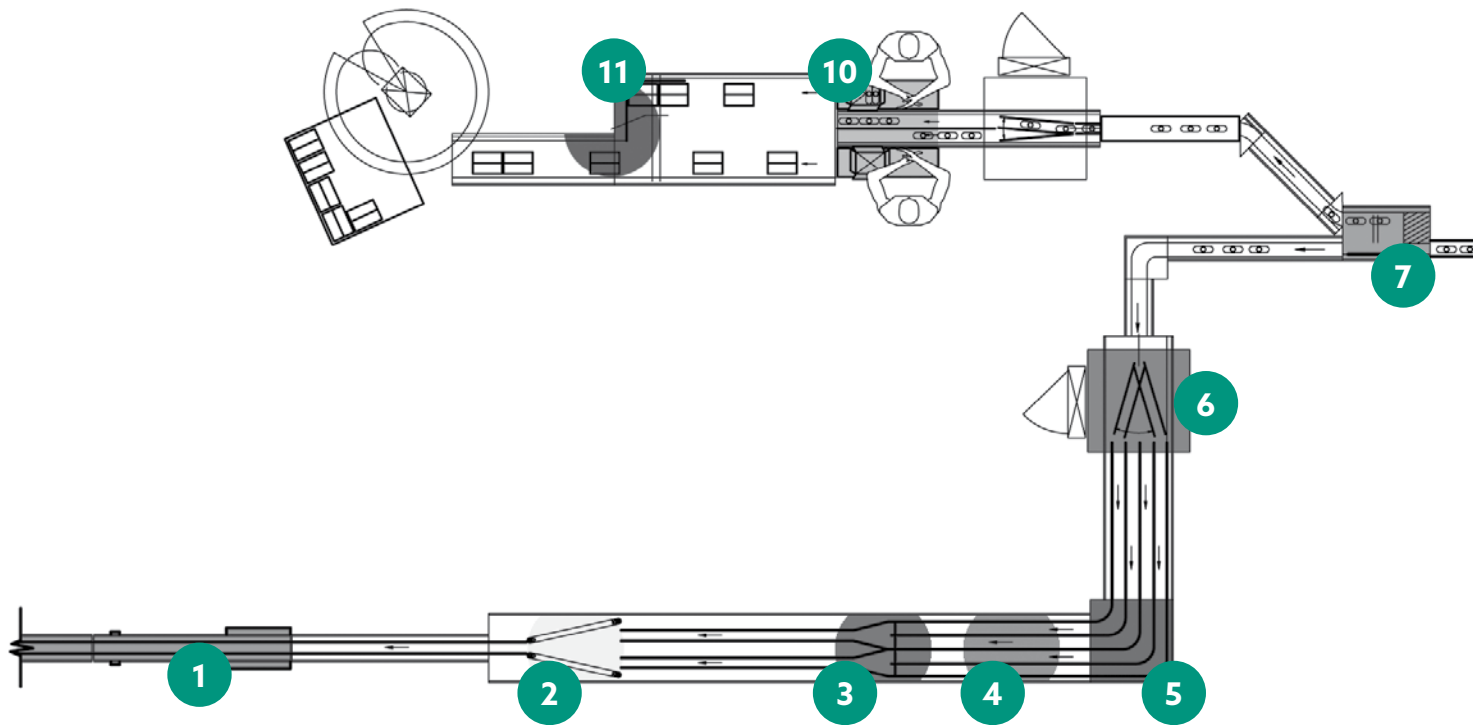

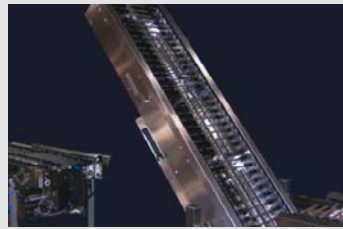
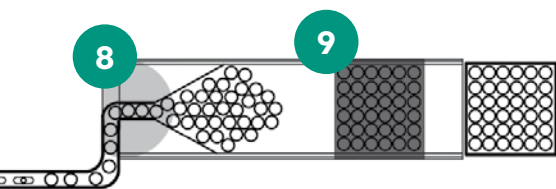

1. Lift Gate



2. Servo Combining



3. Gate Combining



4. Multi-Lane



5. Tight Turn Radius



6. Dividing



7. Product Pushing



8. Single Rowing



9. Mass Accumulation



10. Manual Pack Station



11. Case Packer Infeed

# PROVEN PRODUCT HANDLING SOLUTIONS

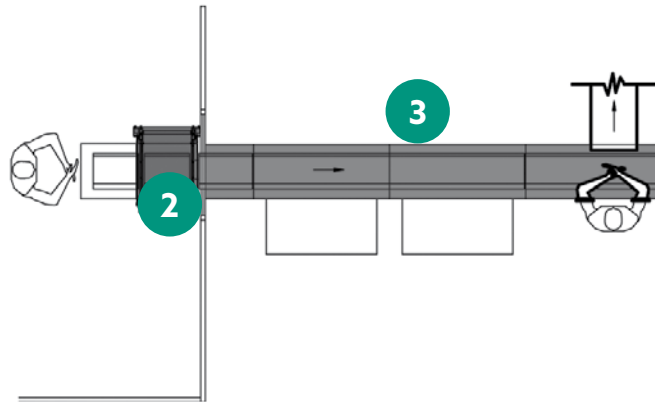
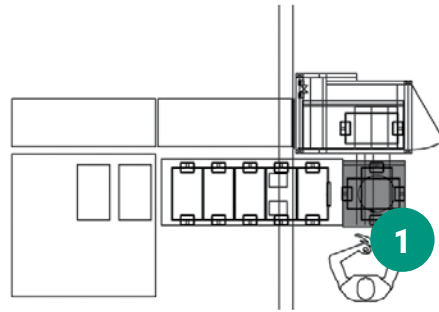

1. Special Tray Handling



2. Clean Pass Through



3. Mini Clean Environment

# OUR CAPABILITIES

Shuttleworth capabilities include electronic data documentation to comply with **Good Manufacturing Process (GMP)** requirements and the **Food and Drug Administration (FDA)** Title 21 Code of Federal Regulations (CFR).



From automotive and electronics, to paper conversion and pharmaceuticals, to food and consumer good markets and beyond, manufacturers across the globe rely on Shuttleworth's proven product handling solutions to increase line efficiency, maximize profitability, and minimize risk. As part of the ProMach Product Handling business line, Shuttleworth helps our packaging customers protect and grow the reputation and trust of their consumers. ProMach is performance, and the proof is in every package.

**World Headquarters - USA**

10 Commercial Rd.,  
Huntington, IN 46570

P: 800-444-7412 / 260-356-8500

F: 260-359-7810

E: [Shuttleworth@ProMachBuilt.com](mailto:Shuttleworth@ProMachBuilt.com)

**[Shuttleworth.com](http://Shuttleworth.com)**

**Shuttleworth Southeast Asia**

PO Box 36, Jinjang,  
52000 Kuala Lumpur, Malaysia

T: 603-62767393

E: [Shuttleworth.Asia@ProMachBuilt.com](mailto:Shuttleworth.Asia@ProMachBuilt.com)

**Shuttleworth Europe**

Karreweg 141A

B-9770 Kruishoutem

Belgium

T: +32-9-221-13 14

E: [Shuttleworth.Europe@ProMachBuilt.com](mailto:Shuttleworth.Europe@ProMachBuilt.com)