

Municipal and Industrial Waste Water Mechanical Pre-treatment WASTEMASTER® TSF 2-3

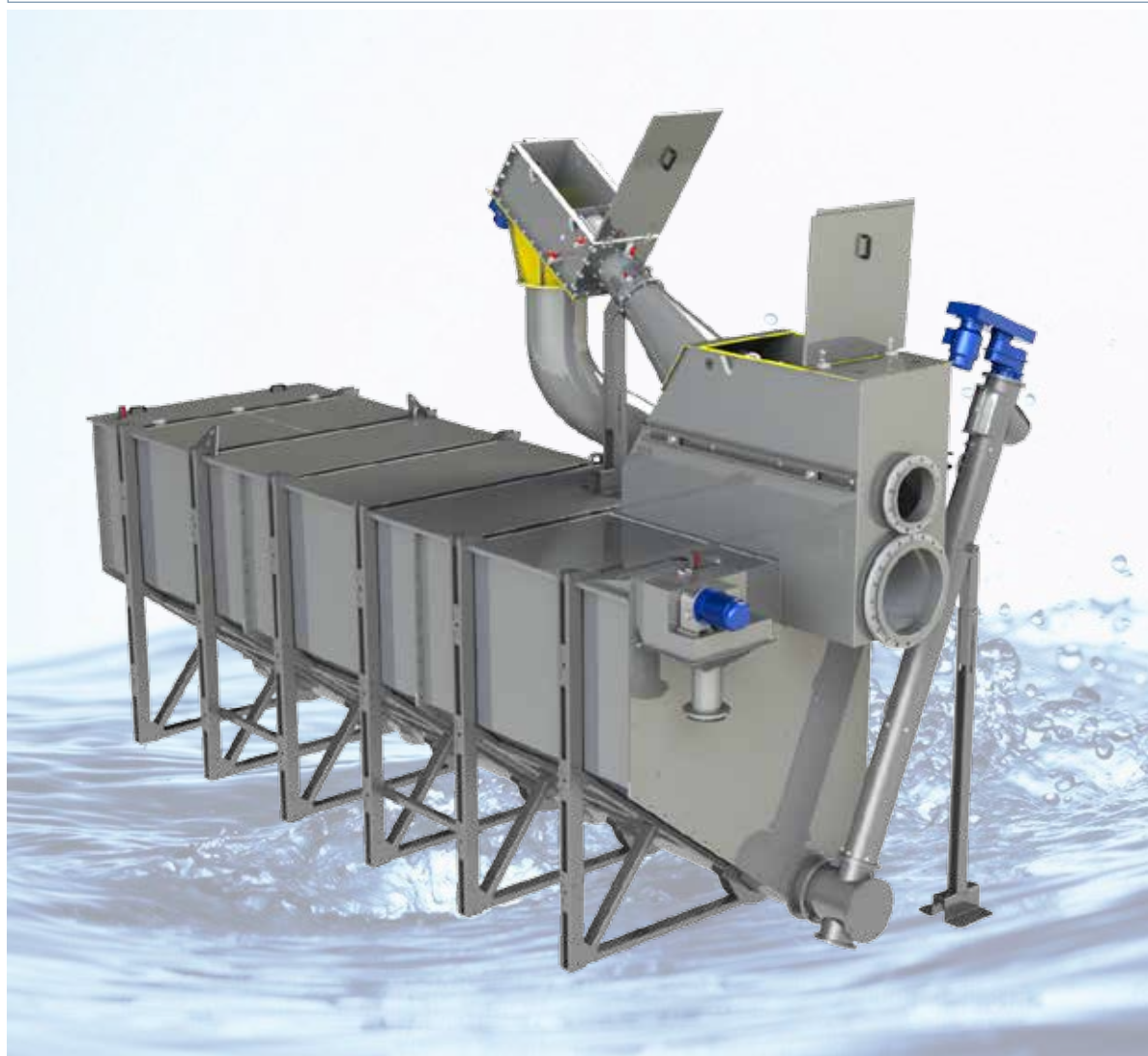

WASTEMASTER® TSF consists of a screw screen, a sedimentation tank, a sand extracting screw and a grease scraper.

	Solids Separation	Sedimentation	De-greasing
TSF 2	X	X	-
TSF 3	X	X	X

The first phase in the waste water treatment process is mechanical pre-treatment including:

- Solid-liquid separation, compaction and de-watering of solids larger in size than the screen slots;
- Sedimentation, lifting and de-watering of sand;
- Grease flotation and removal (TSF 3 only).

Subsequently the waste water is ready for further treatment (chemical, physical or biological), while solids are discharged for disposal.

Features

WASTEMASTER® TSF is designed for a wide range of waste water flow rates with different sedimentation capacities. The possibility to choose the size of the screen perforation/slots, as well as cross section and length of the tank, is the assurance for the customer that he will obtain the right solution to his problem.

The machine comes in high-quality, industrially manufactured, standard modules, ready for comfortable on-site assembly if requested.

The screen section of the plant is equipped with a compacting device in the upper part for a volume reduction of the screenings of up to 35%. A washing system for the reduction of organic matter in the screenings is available on request.

The shaftless screen screw, which is manufactured in an innovative, patented process, ensures smooth operation without clogging even in presence of fibres.

The table below shows an example of how to choose the correct machine according to the requested sedimentation output rate.

TSF 2/3			FLOW RATE *	
Size	Module	Tank length (m)	Min (l/s)	Max (l/s)
S 1 0	1	2	5	13
S 2 0	2	4	12	30
M 1 0	2	4	25	39
M 2 0	3	6	35	60
M 3 0	4	8	60	85
L 1 0	4	8	80	115
L 2 0	5	10	110	145
L 3 0	6	12	140	175
L 4 0	7	14	170	205

* with a grain size of 0.2 mm and a Specific Gravity of 2.60-2.65 w/v

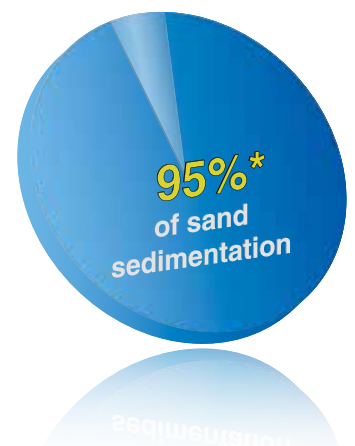



Easy on-site assembly
(if necessary) thanks to
modular design



Easy maintenance thanks
to wide inspection hatches

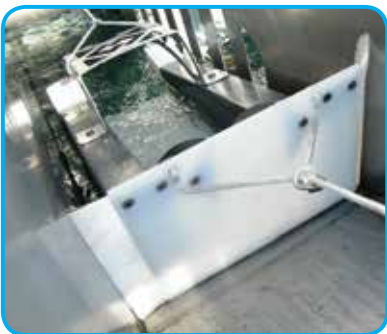
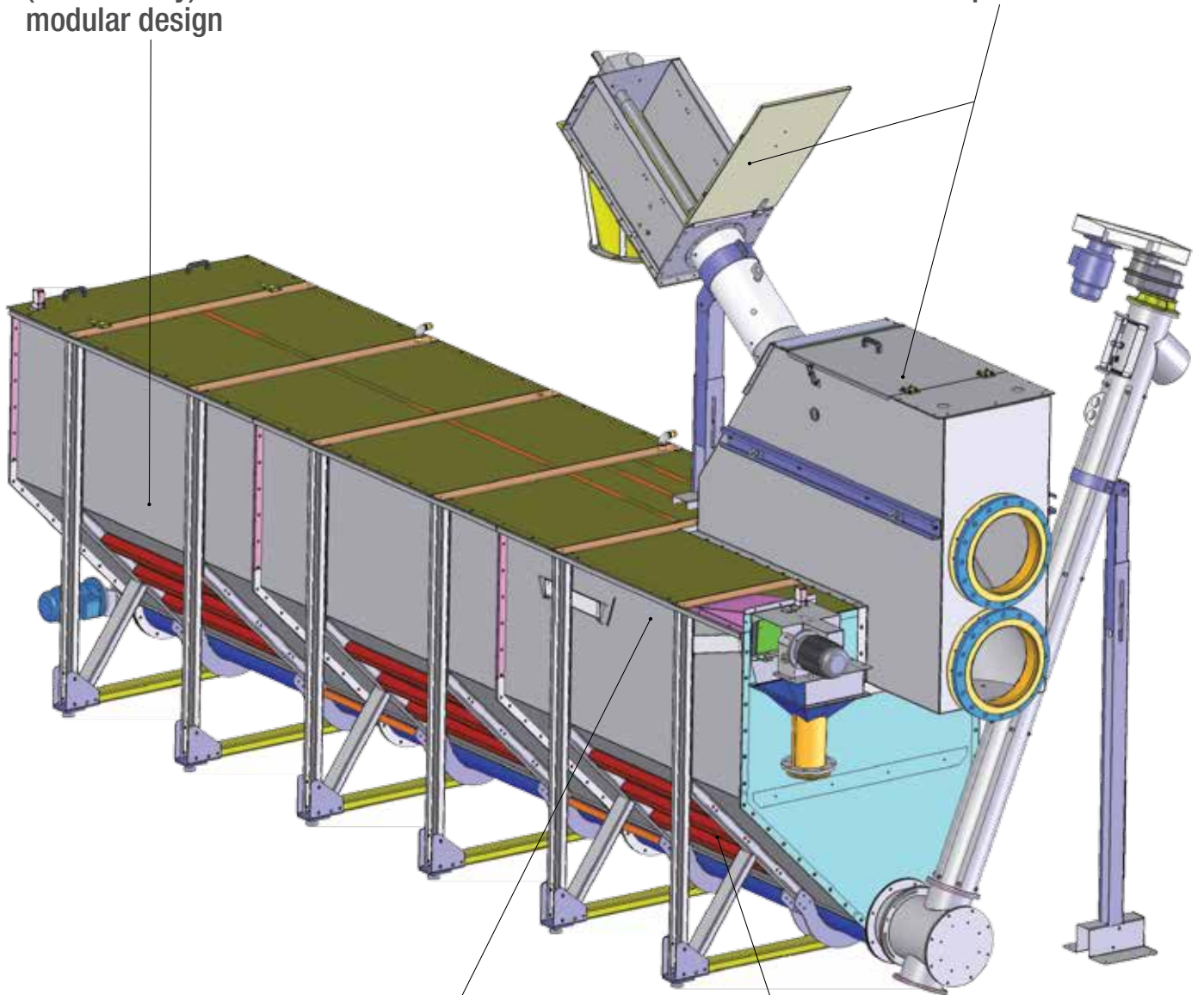

Self-adjusting grease scraper
with limited water removal



Bolted wear bars
(internal view of trough)

Process Description

TSF 2

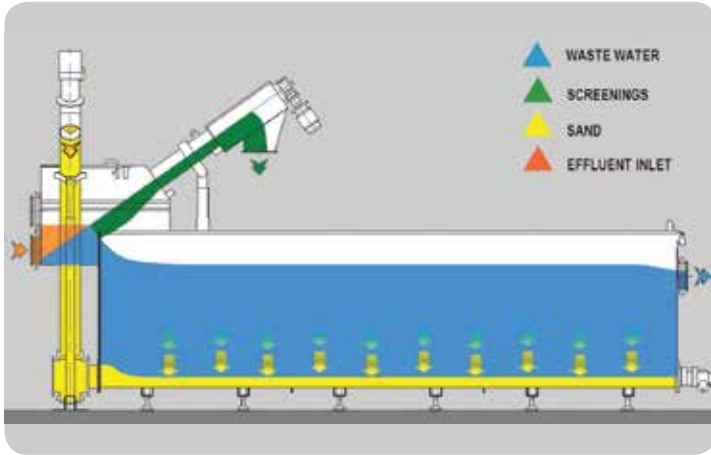

TSF 3

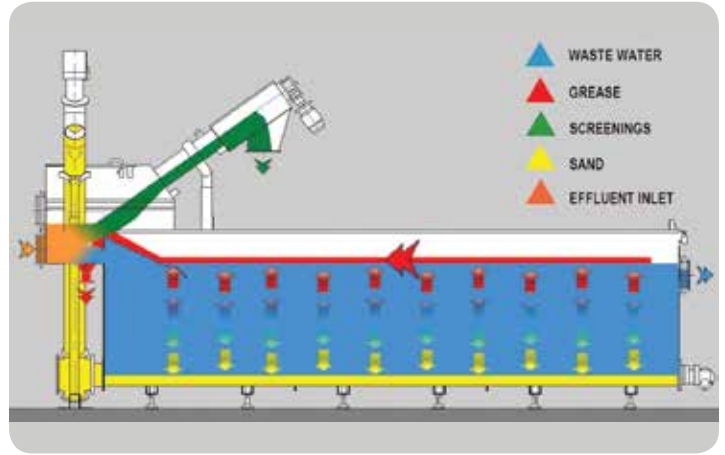

Overall Dimensions

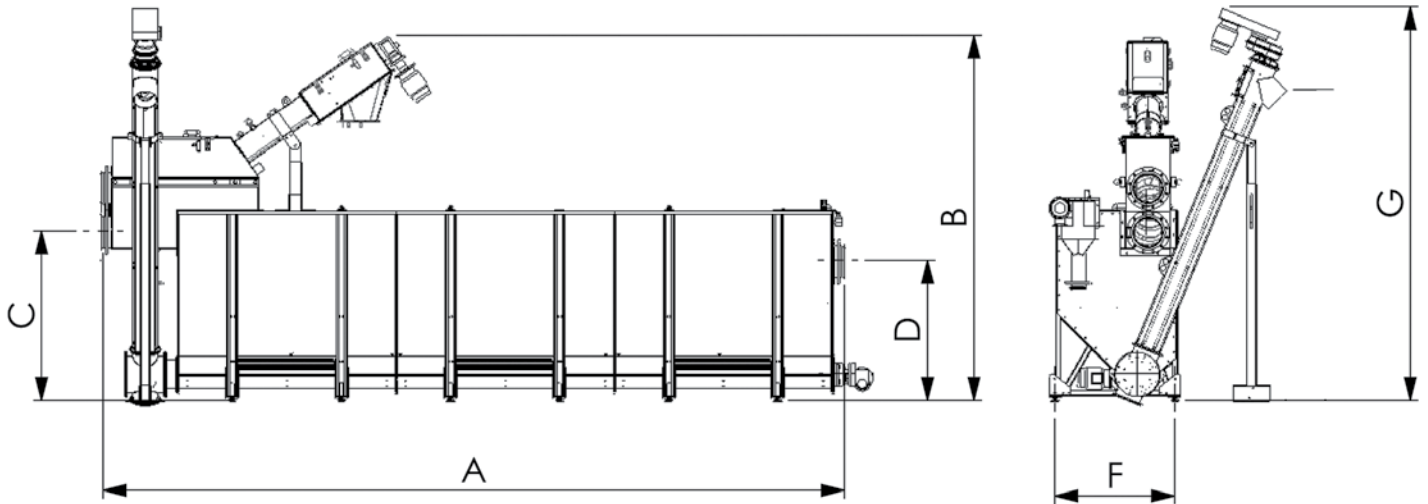

Type	A	B	C	D	F	G
TSF S 10	2,850	3,350	1,550	1,280	1,100	3,610
TSF S 20	4,850	3,350	1,550	1,280	1,100	3,610
TSF M 10	4,830	4,000	1,780	1,460	1,420	3,900
TSF M 20	6,830	4,000	1,780	1,460	1,420	3,900
TSF M 30	8,830	4,000	1,780	1,460	1,420	3,900
TSF L 10	8,820	4,630	2,310	1,750	1,940	4,270
TSF L 20	10,820	4,630	2,310	1,750	1,940	4,270
TSF L 30	12,820	4,630	2,310	1,750	1,940	4,270
TSF L 40	12,820	4,630	2,310	1,750	1,940	4,270

Dimensions in mm

Benefits

- ✓ Decreased infrastructure costs;
- ✓ Easy on-site machine assembly using standard tools → Reduction of intermediate storage costs;
- ✓ Best footprint-net volume ratio for this type of machine;
- ✓ Durable heavy-duty shaftless screws manufactured in patented process;
- ✓ Self-adjusting scraper device (patent pending) → Limited water removal in any flow condition.

Easy on-site machine assembly using standard tools



Reduction of intermediate storage costs

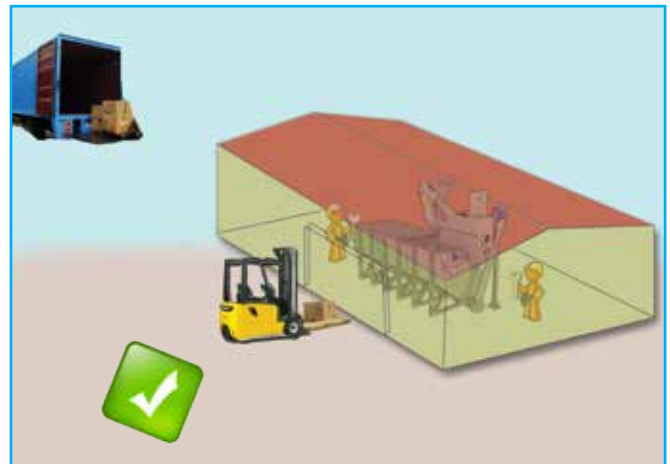

Return On Investment - Life Cycle Cost Calculation Over 15 Years

Life Cycle Cost Comparison between
WASTEMASTER® TSF and traditional concrete construction

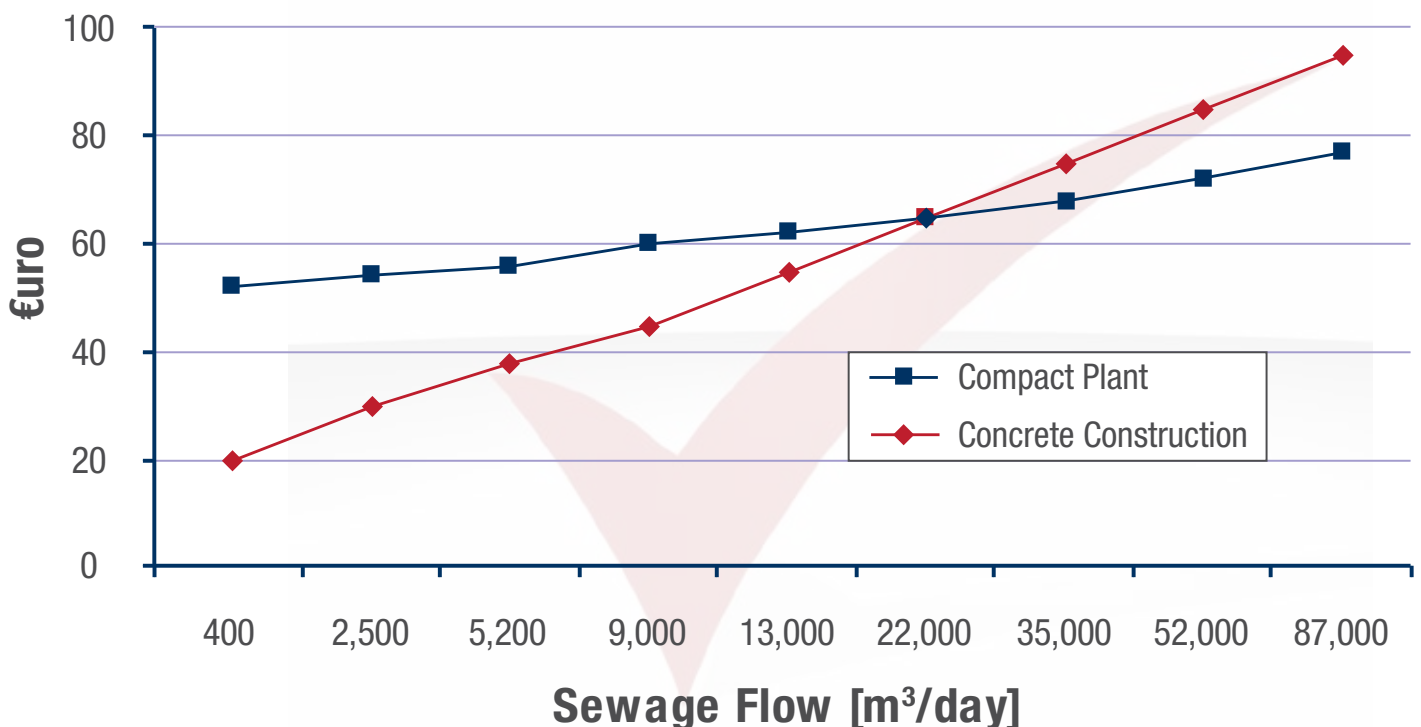

Application



06301495 March 2014 Rights reserved to modify technical specifications.



www.wamgroup.com